



3GPP/3GPP2 Charging in OMA

Approved Version 1.0 – 04 Sep 2007

Open Mobile Alliance
OMA-TS-Charging_3GPP_3GPP2-V1_0-20070904-A

Use of this document is subject to all of the terms and conditions of the Use Agreement located at <http://www.openmobilealliance.org/UseAgreement.html>.

Unless this document is clearly designated as an approved specification, this document is a work in process, is not an approved Open Mobile Alliance™ specification, and is subject to revision or removal without notice.

You may use this document or any part of the document for internal or educational purposes only, provided you do not modify, edit or take out of context the information in this document in any manner. Information contained in this document may be used, at your sole risk, for any purposes. You may not use this document in any other manner without the prior written permission of the Open Mobile Alliance. The Open Mobile Alliance authorizes you to copy this document, provided that you retain all copyright and other proprietary notices contained in the original materials on any copies of the materials and that you comply strictly with these terms. This copyright permission does not constitute an endorsement of the products or services. The Open Mobile Alliance assumes no responsibility for errors or omissions in this document.

Each Open Mobile Alliance member has agreed to use reasonable endeavors to inform the Open Mobile Alliance in a timely manner of Essential IPR as it becomes aware that the Essential IPR is related to the prepared or published specification. However, the members do not have an obligation to conduct IPR searches. The declared Essential IPR is publicly available to members and non-members of the Open Mobile Alliance and may be found on the “OMA IPR Declarations” list at <http://www.openmobilealliance.org/ipr.html>. The Open Mobile Alliance has not conducted an independent IPR review of this document and the information contained herein, and makes no representations or warranties regarding third party IPR, including without limitation patents, copyrights or trade secret rights. This document may contain inventions for which you must obtain licenses from third parties before making, using or selling the inventions. Defined terms above are set forth in the schedule to the Open Mobile Alliance Application Form.

NO REPRESENTATIONS OR WARRANTIES (WHETHER EXPRESS OR IMPLIED) ARE MADE BY THE OPEN MOBILE ALLIANCE OR ANY OPEN MOBILE ALLIANCE MEMBER OR ITS AFFILIATES REGARDING ANY OF THE IPR'S REPRESENTED ON THE “OMA IPR DECLARATIONS” LIST, INCLUDING, BUT NOT LIMITED TO THE ACCURACY, COMPLETENESS, VALIDITY OR RELEVANCE OF THE INFORMATION OR WHETHER OR NOT SUCH RIGHTS ARE ESSENTIAL OR NON-ESSENTIAL.

THE OPEN MOBILE ALLIANCE IS NOT LIABLE FOR AND HEREBY DISCLAIMS ANY DIRECT, INDIRECT, PUNITIVE, SPECIAL, INCIDENTAL, CONSEQUENTIAL, OR EXEMPLARY DAMAGES ARISING OUT OF OR IN CONNECTION WITH THE USE OF DOCUMENTS AND THE INFORMATION CONTAINED IN THE DOCUMENTS.

© 2007 Open Mobile Alliance Ltd. All Rights Reserved.

Used with the permission of the Open Mobile Alliance Ltd. under the terms set forth above.

Contents

1. SCOPE	4
2. REFERENCES	5
2.1 NORMATIVE REFERENCES	5
2.2 INFORMATIVE REFERENCES	5
3. TERMINOLOGY AND CONVENTIONS	6
3.1 CONVENTIONS	6
3.2 DEFINITIONS	6
3.3 ABBREVIATIONS	6
4. INTRODUCTION	7
5. ARCHITECTURAL MODEL	8
5.1 INTRODUCTION (INFORMATIVE)	8
5.2 3GPP/2 CHARGING ARCHITECTURE MODEL SUPPORTING OSE (NORMATIVE)	8
5.3 SYSTEM AND SUBSYSTEM DESCRIPTIONS (NORMATIVE)	9
5.3.1 Offline Charging System	9
5.3.2 On-line Charging System	9
6. INTERFACES	10
6.1 INTRODUCTION (INFORMATIVE)	10
6.2 BETWEEN ENABLER IMPLEMENTATIONS AND 3GPP/2 CHARGING (NORMATIVE)	10
6.2.1 Ro Interface	10
6.2.2 Rf Interface	10
APPENDIX A. CHANGE HISTORY (INFORMATIVE)	11
A.1 APPROVED VERSION HISTORY	11
APPENDIX B. STATIC CONFORMANCE REQUIREMENTS (NORMATIVE)	12

Figures

Figure 1: OMA service enabler interfaces to 3GPP/2 Charging	8
---	---

1. Scope

This Technical Specification (TS) identifies a set of capabilities within the Online Charging System (OCS) and Offline Charging as defined by 3GPP and 3GPP2 that can be utilized for the OMA service enabler implementations.

This TS describes how OMA service enabler implementations interface with an underlying Charging Infrastructure as specified by 3GPP and 3GPP2 in order to ensure interoperability. This Technical Specification is applicable to all OMA service enabler implementations, which use the capabilities of an underlying 3GPP and 3GPP2 infrastructure for charging.

2. References

2.1 Normative References

- [CHRG_ONLINE] “OMA Online Charging Interface”, Open Mobile Alliance™, OMA-TS-Charging_Online-V1_0, URL: <http://www.openmobilealliance.org/>
- [CHRG_OFFLINE] “OMA Offline Charging Interface”, Open Mobile Alliance™, OMA-TS-Charging_Offline-V1_0, URL: <http://www.openmobilealliance.org/>
- [OSE] “OMA Service Environment”, Open Mobile Alliance™, OMA-Service-Environment-V1_0, URL: <http://www.openmobilealliance.org/>
- [RFC2119] “Key words for use in RFCs to Indicate Requirement Levels”, S. Bradner, March 1997, URL: <http://www.ietf.org/rfc/rfc2119.txt>
- [TS32.240] “Telecommunication management; Charging management; Charging architecture and principles”, 3GPP TS32.240Release 6, URL: <http://www.3gpp.org/>
- [TS32.296] “Telecommunication management; Charging management; Online Charging System (OCS): Applications and interfaces”, 3GPP TS32.296 Release 6, URL: <http://www.3gpp.org/>
- [TS32.299] “Telecommunication management; Charging management; Diameter charging applications”, 3GPP TS32.299 Release 6, URL: <http://www.3gpp.org/>
- [X.S0013-007] “All-IP Core Network Multimedia Domain: IP Multimedia Subsystem – Charging Architecture”, 3GPP2 Specification X.S0013-007, URL: <http://www.3gpp2.org>
- [X.S0013-008] “All-IP Core Network Multimedia Domain: IP Multimedia Subsystem - Offline Accounting Information Flows and Protocol”, 3GPP2 Specification X.S0013-008, URL: <http://www.3gpp2.org/>
- [X.S0013-015] “All-IP Core Network Multimedia Domain: IP Multimedia Subsystem - Online Charging System”, 3GPP2 Specification X.S0013-015-B, URL: <http://www.3gpp2.org/>

2.2 Informative References

- [OMA-DICT] “Dictionary for OMA Specifications”, Open Mobile Alliance™, OMA-Dictionary, URL: <http://www.openmobilealliance.org/>

3. Terminology and Conventions

3.1 Conventions

The key words “MUST”, “MUST NOT”, “REQUIRED”, “SHALL”, “SHALL NOT”, “SHOULD”, “SHOULD NOT”, “RECOMMENDED”, “MAY”, and “OPTIONAL” in this document are to be interpreted as described in [RFC2119].

All sections and appendixes, except “Scope” and “Introduction”, are normative, unless they are explicitly indicated to be informative.

3.2 Definitions

For the purposes of this document, the definitions given in [OMA-DICT] apply.

3.3 Abbreviations

3G	3rd Generation
3GPP	3rd Generation Partnership Project
3GPP/2	3GPP and 3GPP2
3GPP2	3rd Generation Partnership Project 2
CDF	Charging Data Function
CGF	Charging Gateway Function
IETF	Internet Engineering Task Force
OMA	Open Mobile Alliance
OSE	OMA Service Environment
RFC	Request for Comments

4. Introduction

The 3GPP/2 charging infrastructure has been developed based on the widespread technical know-how of the mobile communication industry and internet technology to enable the realization of online and offline charging in a mobile environment. Diameter with extensions used for charging is specified in IETF, but in general this document refers to the 3GPP/2 specifications using Diameter rather than to the IETF specifications.

This document describes the use of the 3GPP/2 charging framework in such a way as to ensure that service enablers that use 3GPP/2 charging infrastructure are developed in an interoperable and consistent manner.

It is important to note that OMA and the mobile communications industry in general gain advantage from the exploitation of the existing charging infrastructure. Among these benefits are:

- The service definition process within OMA is facilitated and accelerated
- Continuity of the specification process from 3GPP/2 can be maintained.
- Duplication of work between OMA and 3GPP/2 can be avoided.
- Improved communication and information sharing can be achieved between OMA and 3GPP/2 when the terms, definitions and concepts are the same.
- Maximised reuse of charging infrastructure and network mechanisms can be made to protect the investments and efforts of the cellular industry and to reduce additional costs by leveraging current investments

The 3GPP/2 charging architecture provides solutions for charging in 3GPP/2 networks. However, these specific solutions can be addressed in other methods depending on the specific needs of the Infrastructure Provider. The decision of the Infrastructure Provider to meet their needs outside of 3GPP/2 charging specific solution shall not prevent the Infrastructure Provider from utilizing OMA developed service enablers that utilise the same protocols. When developing OMA service enablers it can be assumed that the underlying network provides the same functionality as 3GPP/2 charging. Further, OMA may work on service enablers that take advantage of 3GPP/2 charging.

5. Architectural Model

5.1 Introduction (Informative)

This chapter describes how an OMA Enabler Implementation (Charging Enabler User) can interact with the 3GPP/2 charging infrastructure. Also the charging systems in 3GPP/2 are described in this chapter.

5.2 3GPP/2 Charging Architecture Model Supporting OSE (Normative)

The main components of the 3GPP/2 charging architecture, the OMA enablers and the interfaces between them are depicted in Figure 1. The 3GPP/2 charging interfaces are described in chapter 6 and the functionalities of the main 3GPP/2 charging elements in the figure are described in chapter 5.3.

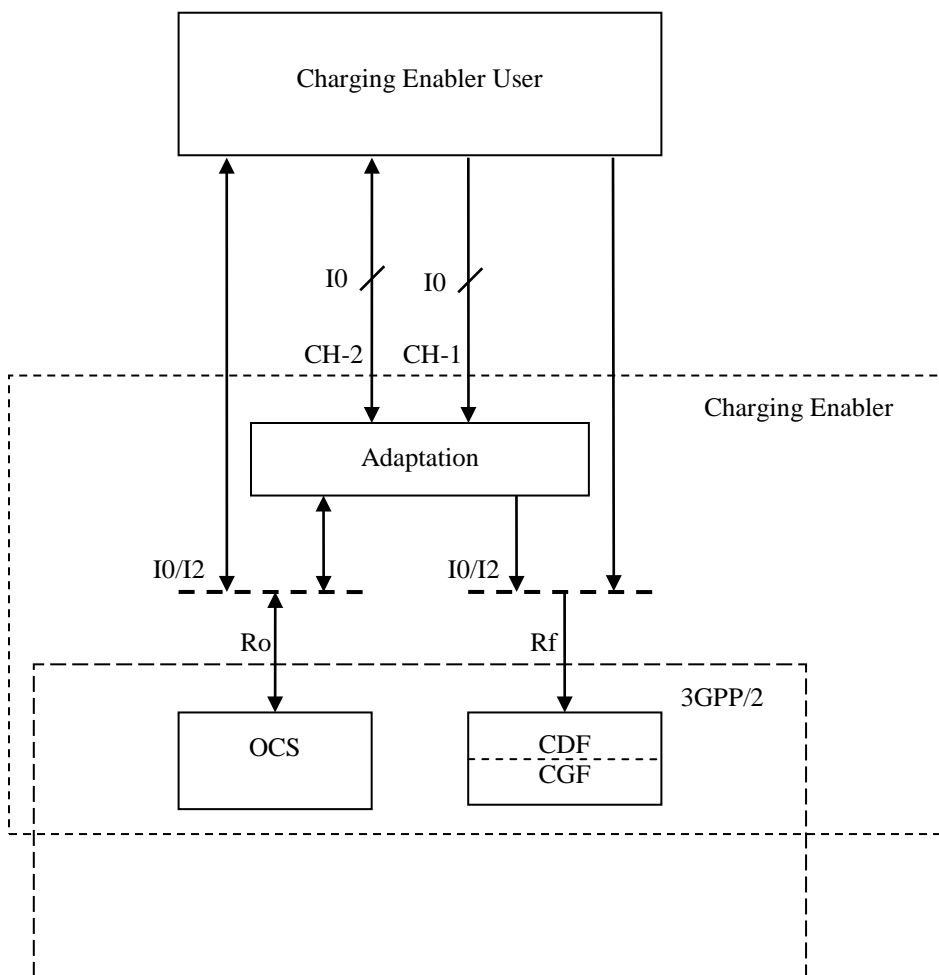

Figure 1: OMA service enabler interfaces to 3GPP/2 Charging

The OCS implements parts or all of the following functions from the OMA Charging Architecture: Quota Management, Rating and Account Balance Management.

The CGF together with CDF implements the following functions from the OMA Charging Architecture: Correlation/Aggregation.

The picture above shows how the interfaces, Ro and Rf, in 3GPP/2 can be reused in OMA in two different deployment scenario as either I0 or I2 interfaces.

In a deployment scenario where Ro and Rf interfaces are used as I0 interfaces, from charging enabler user perspective, the Rf interface corresponds to the CH-1 interface, and Ro to CH-2. The functions of the OMA Charging Enabler are implemented by the 3GPP/2 charging infrastructure in this deployment scenario.

In the other deployment scenario where Ro and Rf interfaces are used as I2 interfaces, from charging enabler user perspective, it will use CH-1 and CH-2 to implement charging. In this case, there is a need for some kind of adaptation between the Charging Enabler User and the 3GPP/2 network.

5.3 System and Subsystem Descriptions (Normative)

There are separate systems for off-line and on-line charging in 3GPP/2, which are described below. 3GPP2's current release only supports off-line charging. However, the next 3GPP2 revision will include on-line charging.

5.3.1 Offline Charging System

In 3GPP the Charging Data Function (CDF) and the Charging Gateway Function (CGF) are used for offline charging. An Enabler Implementation shall report accounting information to the CDF/CGF. The CDF/CGF uses this information to construct and format Charging Data Records (CDR). The CDF and CGF are specified in 3GPP [TS32.240].

In 3GPP2, the equivalent entity for collection of charging data is the AAA. The AAA uses accounting information to construct and format Accounting Information Records. The functionality is specified in 3GPP2 [X.S0013-007].

5.3.2 On-line Charging System

In 3GPP systems, Online Charging System (OCS) is used for online charging. An Enabler Implementation shall request credit-control information from the OCS using the Ro interface for online charging. The online charging Ro functionality is defined in [TS32.299]. The OCS is located at the home network of the end user terminal. The OCS, containing specific functions for Rating and Account Management Balance, is defined in 3GPP [TS32.296].

3GPP2 has the equivalent application for collection of charging data. The AAA uses accounting information to construct and format on-line Accounting Information Records. The functionality is specified in 3GPP2 [X.S0013-015].

6. Interfaces

6.1 Introduction (Informative)

This chapter contains the information on what interfaces that will be used when an OMA Enabler Implementation interacts with 3GPP/2 charging infrastructure.

6.2 Between enabler implementations and 3GPP/2 Charging (Normative)

6.2.1 Ro Interface

The Ro interface supports integrity protection and authentication for the case that the Enabler Implementation is outside the operator domain. In 3GPP the Ro is based on Diameter Credit-Control Application, specified in 3GPP [TS32.299]. In 3GPP2, the Ro is based on a similar application specified in [X.S0013-015].

6.2.2 Rf Interface

The Rf interface offers reliable and extendable transfer of Charging Information to 3GPP's CDF and 3GPP2's AAA with acknowledgement mechanisms and redundancy mechanisms. In 3GPP2 and 3GPP, Rf is based on Diameter Accounting Application, specified in [X.S0013-008] and [TS32.299] respectively.

Appendix A. Change History

(Informative)

A.1 Approved Version History

Reference	Date	Description
OMA-TS-Charging_3GPP_3GPP2-V1_0-20070904-A	04 Sep 2007	Status changed to Approved by TP Ref #: OMA-TP-2007-0303-INP_Charging_V1_0_ERP_for_final_approval

Appendix B. Static Conformance Requirements (Normative)

The static conformance requirements for online charging are described in [CHRG_ONLINE].

The static conformance requirements for offline charging are described in [CHRG_OFFLINE].