



# **Immersive Social Centre Architecture**

Approved Version 1.0 – 30 Jun 2015

---

**Open Mobile Alliance**  
OMA-AD-ISC-V1\_0-20150630-A

Use of this document is subject to all of the terms and conditions of the Use Agreement located at <http://www.openmobilealliance.org/UseAgreement.html>.

Unless this document is clearly designated as an approved specification, this document is a work in process, is not an approved Open Mobile Alliance™ specification, and is subject to revision or removal without notice.

You may use this document or any part of the document for internal or educational purposes only, provided you do not modify, edit or take out of context the information in this document in any manner. Information contained in this document may be used, at your sole risk, for any purposes. You may not use this document in any other manner without the prior written permission of the Open Mobile Alliance. The Open Mobile Alliance authorizes you to copy this document, provided that you retain all copyright and other proprietary notices contained in the original materials on any copies of the materials and that you comply strictly with these terms. This copyright permission does not constitute an endorsement of the products or services. The Open Mobile Alliance assumes no responsibility for errors or omissions in this document.

Each Open Mobile Alliance member has agreed to use reasonable endeavors to inform the Open Mobile Alliance in a timely manner of Essential IPR as it becomes aware that the Essential IPR is related to the prepared or published specification. However, the members do not have an obligation to conduct IPR searches. The declared Essential IPR is publicly available to members and non-members of the Open Mobile Alliance and may be found on the “OMA IPR Declarations” list at <http://www.openmobilealliance.org/ipr.html>. The Open Mobile Alliance has not conducted an independent IPR review of this document and the information contained herein, and makes no representations or warranties regarding third party IPR, including without limitation patents, copyrights or trade secret rights. This document may contain inventions for which you must obtain licenses from third parties before making, using or selling the inventions. Defined terms above are set forth in the schedule to the Open Mobile Alliance Application Form.

**NO REPRESENTATIONS OR WARRANTIES (WHETHER EXPRESS OR IMPLIED) ARE MADE BY THE OPEN MOBILE ALLIANCE OR ANY OPEN MOBILE ALLIANCE MEMBER OR ITS AFFILIATES REGARDING ANY OF THE IPR'S REPRESENTED ON THE “OMA IPR DECLARATIONS” LIST, INCLUDING, BUT NOT LIMITED TO THE ACCURACY, COMPLETENESS, VALIDITY OR RELEVANCE OF THE INFORMATION OR WHETHER OR NOT SUCH RIGHTS ARE ESSENTIAL OR NON-ESSENTIAL.**

**THE OPEN MOBILE ALLIANCE IS NOT LIABLE FOR AND HEREBY DISCLAIMS ANY DIRECT, INDIRECT, PUNITIVE, SPECIAL, INCIDENTAL, CONSEQUENTIAL, OR EXEMPLARY DAMAGES ARISING OUT OF OR IN CONNECTION WITH THE USE OF DOCUMENTS AND THE INFORMATION CONTAINED IN THE DOCUMENTS.**

© 2015 Open Mobile Alliance Ltd. All Rights Reserved.

Used with the permission of the Open Mobile Alliance Ltd. under the terms set forth above.

# Contents

1. SCOPE (INFORMATIVE) .....	5
2. REFERENCES .....	6
2.1 NORMATIVE REFERENCES .....	6
2.2 INFORMATIVE REFERENCES .....	6
3. TERMINOLOGY AND CONVENTIONS .....	7
3.1 CONVENTIONS .....	7
3.2 DEFINITIONS .....	7
3.3 ABBREVIATIONS .....	8
4. INTRODUCTION (INFORMATIVE) .....	9
4.1 VERSION 1.0 .....	9
5. ARCHITECTURAL MODEL .....	10
5.1 DEPENDENCIES .....	10
5.2 ARCHITECTURAL DIAGRAM .....	10
5.3 FUNCTIONAL COMPONENTS AND INTERFACES/REFERENCE POINTS DEFINITION .....	12
5.3.1 ISC Client .....	12
5.3.2 ISC Server .....	14
5.3.3 ISC XDMS(s) .....	18
5.3.4 ISC CP Gateway .....	19
5.3.5 External Functional Components .....	19
5.3.6 Interfaces .....	22
5.3.7 External Interfaces .....	23
5.4 SECURITY CONSIDERATIONS .....	24
5.4.1 Authentication .....	24
5.4.2 Authorization .....	24
5.4.3 Confidentiality and Integrity .....	24
5.5 CHARGING CONSIDERATIONS .....	25
APPENDIX A. CHANGE HISTORY (INFORMATIVE) .....	26
A.1 APPROVED VERSION HISTORY .....	26
APPENDIX B. FLOWS (INFORMATIVE) .....	27
B.1 SYNCHRONIZATION OF CONTENT VIEWING .....	27
B.1.1 1-1 Content Viewing Synchronization between the ISC Clients .....	27
B.1.2 1-N Content Viewing Synchronization in Content Viewing Group .....	28
B.2 COMMUNICATION .....	29
B.2.1 Communication between the ISC Users .....	29
B.2.2 Communication between the ISC User and the Content Provider .....	29
APPENDIX C. ADDITIONAL INFORMATION (INFORMATIVE) .....	30
C.1 ISC INTERACTIONS WITH SUPPORTING ENABLERS .....	30

## Figures

Figure 1: Architecture Diagram Conventions .....	7
Figure 2: ISC Architectural Diagram using interfaces .....	10
Figure 3: 1-1 Synchronization of Content Viewing .....	27
Figure 4: 1-N Synchronization of Content Viewing in Content Viewing Group .....	28
Figure 5: Communication between the ISC Users .....	29
Figure 6: Interactions between the ISC Server functional components and the supporting Enablers .....	30

**Figure 7: Interactions between the ISC Enabled Device and the supporting Enablers.....31**

# 1. Scope

**(Informative)**

This document defines the architecture for the Immersive Social Centre (ISC) Enabler.

This document describes the architecture to fulfill all the requirements specified by the Requirements Document [OMA-ISC-RD] for the ISC Enabler 1.0.

The description of the architecture comprises the definition of the functional components and the interfaces used or exposed by these components. In addition, this document identifies the relationship to external functional components that are utilized by the ISC Enabler.

## 2. References

### 2.1 Normative References

- [3GPP TS23.228] “IP Multimedia Subsystem (IMS); Stage 2”, 3GPP, TS23.228, [URL:http://www.3gpp.org/](http://www.3gpp.org/)
- [3GPP2 X.S0013-002] “All-IP Core Network Multimedia Domain - IP Multimedia Subsystem (IMS) - Stage-2”, 3GPP2, X.S0013-002-A, [URL:http://www.3gpp2.org/](http://www.3gpp2.org/)
- [OMA SEC\_CF-V1\_1] “Security Common Functions”, Version 1.1, Open Mobile Alliance™, [URL:http://www.openmobilealliance.org/](http://www.openmobilealliance.org/)
- [OMA-CPM-AD] “Converged IP Messaging Architecture”, Open Mobile Alliance™, OMA-AD-CPM-V2\_0, [URL:http://www.openmobilealliance.org](http://www.openmobilealliance.org/)
- [OMA-DM-PRO] “Device Management Protocol”, Open Mobile Alliance™, OMA-TS-DM\_Protocol-V1\_2, [URL:http://www.openmobilealliance.org/](http://www.openmobilealliance.org/)
- [OMA-ISC-RD] “OMA ISC Requirements”, Open Mobile Alliance™, OMA-RD-ISC-V1\_0, [URL:http://www.openmobilealliance.org/](http://www.openmobilealliance.org/)
- [OMA-PRS-AD] “Presence SIMPLE Architecture”, Open Mobile Alliance™, OMA-AD-Presence\_SIMPLE-V2\_0, [URL:http://www.openmobilealliance.org/](http://www.openmobilealliance.org/)
- [OMA-PRS-RD] “Presence SIMPLE Requirements”, Open Mobile Alliance™, OMA-RD-Presence\_SIMPLE-V2\_0, [URL:http://www.openmobilealliance.org/](http://www.openmobilealliance.org/)
- [OMA-PUSH-AD] “Push Architecture”, Open Mobile Alliance™, OMA-AD-Push-V2\_2, [URL:http://www.openmobilealliance.org/](http://www.openmobilealliance.org/)
- [OMA-XDM-AD] “XML Document Management Architecture”, Open Mobile Alliance™, OMA-AD-XDM-V2\_2, [URL:http://www.openmobilealliance.org/](http://www.openmobilealliance.org/)
- [OSE] “OMA Service Environment”, Open Mobile Alliance™, [URL:http://www.openmobilealliance.org/](http://www.openmobilealliance.org/)
- [RFC2119] “Key words for use in RFCs to Indicate Requirement Levels”, S. Bradner, March 1997, [URL:http://www.ietf.org/rfc/rfc2119.txt](http://www.ietf.org/rfc/rfc2119.txt)
- [RFC2327] “SDP: Session Description Protocol”, M. Handley, April 1998, [URL:http://www.ietf.org/rfc/rfc2327.txt](http://www.ietf.org/rfc/rfc2327.txt)
- [RFC3261] “SIP: Session Initiation Protocol”, J. Rosenberg, H. Schulzrinne, G. Camarillo, A. Johnston, J. Peterson, R. Sparks, M. Handley, E. Schooler, June 2002, [URL:http://www.ietf.org/rfc/rfc3261.txt](http://www.ietf.org/rfc/rfc3261.txt)
- [RFC3325] “Private Extensions to the Session Initiation Protocol (SIP) for Asserted Identity within Trusted Networks”, C. Jennings, J. Peterson, M. Watson, November 2002, [URL:http://www.ietf.org/rfc/rfc3325.txt](http://www.ietf.org/rfc/rfc3325.txt)
- [RFC3711] “The Secure Real-time Transport Protocol (SRTP)”, M. Baugher, D. McGrew, M. Naslund, E. Carrara, K. Norrman, March 2004, [URL:http://www.ietf.org/rfc/rfc3711.txt](http://www.ietf.org/rfc/rfc3711.txt)
- [RFC5628] “Registration Event Package Extension for Session Initiation Protocol (SIP), Globally Routable User Agent URIs (GRUUs)”, P. Kyzivat, October 2009, [URL:http://www.ietf.org/html/rfc5628.txt](http://www.ietf.org/html/rfc5628.txt)

### 2.2 Informative References

- [OMA-CAB-AD] “Converged Address Book Architecture”, Open Mobile Alliance™, OMA-AD-CAB-V1\_0, [URL:http://www.openmobilealliance.org/](http://www.openmobilealliance.org/)
- [OMA-CHG-AD] “Charging Architecture”, Version 1.1, Open Mobile Alliance™, OMA-AD-Charging-V1\_1, [URL:http://www.openmobilealliance.org/](http://www.openmobilealliance.org/)
- [OMADICT] “Dictionary for OMA Specifications”, Version x.y, Open Mobile Alliance™, OMA-ORG-Dictionary-Vx\_y, [URL:http://www.openmobilealliance.org/](http://www.openmobilealliance.org/)

## 3. Terminology and Conventions

### 3.1 Conventions

The key words “MUST”, “MUST NOT”, “REQUIRED”, “SHALL”, “SHALL NOT”, “SHOULD”, “SHOULD NOT”, “RECOMMENDED”, “MAY”, and “OPTIONAL” in this document are to be interpreted as described in [RFC2119].

All sections and appendixes, except “Scope” and “Introduction”, are normative, unless they are explicitly indicated to be informative.

All architecture diagrams in this document adhere to the conventions depicted in Figure 1.

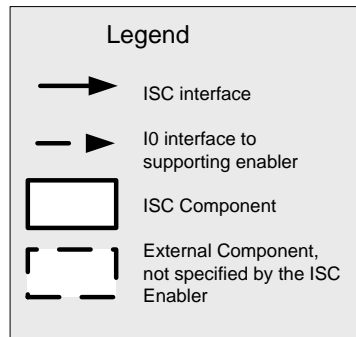

Figure 1: Architecture Diagram Conventions

### 3.2 Definitions

<b>Address Book</b>	See [OMA-ISC-RD]
<b>Associated Contents</b>	See [OMA-ISC-RD]
<b>Content Provider</b>	See [OMADICT]
<b>Content View</b>	See [OMA-ISC-RD]
<b>Content Viewing Group</b>	See [OMA-ISC-RD]
<b>Content Viewing Information</b>	See [OMA-ISC-RD]
<b>Continuous Content View</b>	See [OMA-ISC-RD]
<b>ISC Client</b>	A functional component of the ISC architecture, as defined in this document.
<b>ISC Server</b>	A functional component of the ISC architecture, as defined in this document.
<b>ISC Session</b>	A logical session for content viewing and/or communication among ISC Users, the ISC Server and the Content Provider.
<b>ISC User</b>	See [OMA-ISC-RD]
<b>ISC User Address</b>	A unique identifier for an ISC User.
<b>Non-ISC User</b>	See [OMA-ISC-RD]
<b>Participant</b>	See [OMADICT]
<b>Presence Information</b>	See [OMA-PRS-RD].
<b>Primary Content</b>	A media that is selected for content viewing by the ISC User such as TV program, audio or video clip, etc. and may be supplemented by Associated Contents.
<b>Principal</b>	See [OMADICT]
<b>Spatial Configuration</b>	See [OMA-ISC-RD]

**User Preferences Profile** A set of user settings which controls aspects of how a user perceives and receives services; a user may have several such profiles.

### 3.3 Abbreviations

<b>3GPP</b>	3rd Generation Partnership Project
<b>3GPP2</b>	3rd Generation Partnership Project 2
<b>CAB</b>	Converged Address Book
<b>CPM</b>	Converged IP Messaging
<b>DM</b>	Device Management
<b>IETF</b>	Internet Engineering Task Force
<b>ISC</b>	Immersive Social Centre
<b>MMD</b>	Multimedia Domain
<b>OMA</b>	Open Mobile Alliance
<b>PRS</b>	Presence
<b>RFC</b>	Request For Comments
<b>SDP</b>	Session Description Protocol
<b>SIP</b>	Session Initiation Protocol
<b>XDM</b>	XML Document Management
<b>XDMS</b>	XML Document Management Server
<b>XML</b>	eXtensible Markup Language



## 4. Introduction (Informative)

The ISC Enabler provides a service-level framework (mainly leveraging SIP) to enable a standardized integration of content viewing and communication environment using multiple devices while providing an immersive (being-there, being-with) experience.

This architecture document is based on the requirements defined in [OMA-ISC-RD]. It describes the ISC Enabler with all functional components, which includes:

- Functions of the ISC Server: Interaction with ISC Client, ISC XDMS, ISC CP Gateway and Supporting Server(s). The ISC Server provides the following functions: Content listing and content viewing, delivery of Primary Content and Associated Content, Communication, Social Interaction, Storage Management, Media-Handling, Multi-device Discovery
- Functions of the ISC Client: Interaction with ISC Server, ISC XDMS and Supporting Server(s) and supporting client functions
- Functions of the Supporting Server: Interaction with ISC Client, ISC Server and ISC XDMS, providing supporting functions for: XDM, Presence, DM, CAB, Push, CPM, and ISC-specific supporting functions based on XDM and PRS
- Functions of ISC CP Gateway: Interaction with ISC Server and Supporting Server(s), supporting Social Interaction and Communication between ISC User and Content Provider.

The ISC interfaces between the functional components are specified including interaction with security and charging enablers.

### 4.1 Version 1.0

The Architecture Document of ISC Enabler 1.0 addresses all the requirements in [OMA-ISC-RD] marked as both “ISC V1.0” and “Future” in order to keep future proof for future requirements.

## 5. Architectural Model

### 5.1 Dependencies

The ISC Enabler utilizes several existing technologies specified in OMA Enablers and other non-OMA specifications (IETF, 3GPP, 3GPP2).

The ISC Enabler depends on technologies provided by other OMA Enablers, including the following:

- Address book technology: CAB Enabler as described in [OMA-CAB-AD]
- Communication technology: CPM Enabler as described in [OMA-CPM-AD]
- XML document management technology: XDM Enabler as described in [OMA-XDM-AD]
- Device provisioning technology : Device Management Enabler as described in [OMA-DM-PRO]
- Notification delivery technology : Push Enabler as described in [OMA-PUSH-AD]
- Presence technology: Presence Enabler as described in [OMA-PRS-AD]

Furthermore, the ISC Enabler is dependent on an underlying SIP/IP core infrastructure to transport SIP messages between the ISC functional components. A particular instantiation of the SIP/IP core infrastructure is the IP Multimedia Subsystem as specified in either [3GPP TS23.228] or [3GPP2 X.S0013-002].

### 5.2 Architectural Diagram

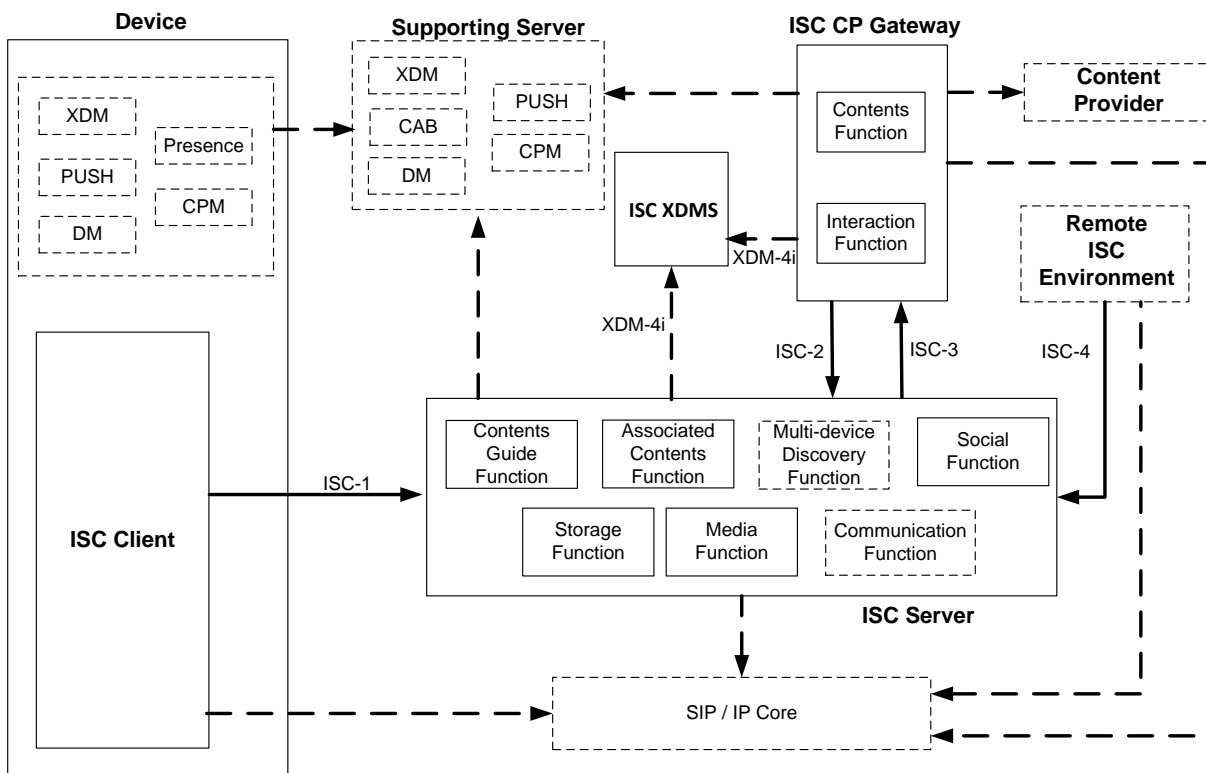

Figure 2: ISC Architectural Diagram using interfaces

Figure 2 presents the ISC architecture diagram model, depicting the ISC Enabler's functional components and their interactions with each other and with external entities such as the Supporting Enablers.

The ISC Enabler consists of the following ISC functional components:

- The ISC Client, which resides in the user's Device and allows the ISC User to use the ISC-based services by interacting with other ISC functional components.
- The ISC Server, which resides in the network domain and interacts with the ISC Client and other network components such as the ISC XDMS and the ISC CP Gateway, and has the following functional components:
  - Contents Guide Function
  - Associated Content Function
  - Storage Function
  - Multi-device Discovery Function
  - Communication Function (CPM Enabler server-side functional components)
  - Media Function
  - Social Function
- The ISC XDMS, which resides in the network domain and is a logical server entity which provides XML document management specific for the ISC Enabler.
- The ISC CP Gateway, resides in network domain and allows the ISC User to communicate and exchange media contents with the Content Provider(s) via ISC Server, and has two logical functional components, Content Function and Interaction Function.

The ISC functional components, if and when needed, interact with the following external functional components:

- A SIP/IP core, which is an underlying infrastructure that provides SIP-based and IP-based functionalities that are needed to support the ISC Enabler. See section 5.3.5.1 for details of this external functional component.
- The following supporting Enablers, which are other OMA Enablers used to support the ISC Enabler:
  - The ISC Server Communication Function acts as a the CPM Enabler server-side functional components, which provides communication capabilities to support interactions between the ISC Users and the Content Provider, and among the ISC Users.
  - The XDM Enabler, which provides XML document management capabilities to support creating, storing and managing the user and service data such as the user preferences, the service provider policy.
  - The Push Enabler, which provides push notifications to support informing multiple devices about server-side events.
  - The DM Enabler, which provides device management to support remote management of ISC-specific device parameters.
  - The ISC Server Social Function and Multi-device Discovery Function act as Presence Servers of Presence Enabler's server-side functional components, which provide the capabilities of retrieving and publishing the user's presence information (including Device Presence Information)
  - The CAB Enabler, which provides the management capabilities about the user's address-book.
- A Content Provider component, which supports the functionalities of Social Interaction and Communication between the Content Provider and the ISC Users. See section 5.3.5.9 for details of this external functional component.

The ISC functional components expose their functionalities to the following external functional components:

- A Remote ISC Environment, which is a ISC environment residing in another (remote) network. See section 5.3.5.8 for details of this external functional component.

Appendix C.1 provides more information about the relationship between the ISC functional components and the Supporting Enablers.

## 5.3 Functional Components and Interfaces/reference points definition

### 5.3.1 ISC Client

The ISC Client resides in a Device. It is used to access network-based ISC functional components. The other functional components in the Device may communicate internally with the ISC Client. More detail on the network-based ISC functional components can be found in section 5.3.2.

NOTE: Specifying interfaces or protocols for internal communication within a Device is out of scope of the ISC Enabler.

The ISC Client SHALL support the following functionalities:

- Registration of the ISC Client, the ISC User's Address (es) and the ISC device identifier.
- Performing ISC Users communication related functions
  - Generating, sending and receiving standalone messages and chat messages
  - Sending and receiving whole or part of the contents and/or the reference of whole or parts of the content
  - Generating a content to be delivered at a later time.
  - Performing ISC Session handling related functions (e.g. creating, modifying, tearing down)
- Performing Content Viewing Group related functions
  - Creating, deleting, modifying, and searching for pre-defined/ad-hoc Content Viewing Group
  - Inviting participants, requesting to join into and requesting to remove participants from pre-defined/ad-hoc Content Viewing Group
  - Joining into, leaving from Content Viewing Group
- Performing multi-device task management related functions
  - Requesting to stop/suspend content viewing for future resuming
  - Resuming stopped/suspended content viewing with the same device or other device of the same ISC User
  - Upon the ISC User's request, selecting supported tasks for communication and/or content viewing.
- Performing Content View synchronization related functions (e.g. start/stop synchronizing)
- Managing the ISC User' context(e.g., same Content Viewing or not, Content View changed) of of the content being viewed
- Performing device capability information related functions
  - Subscribing device capability information of the same user's device(s) and/or other user's device(s)
  - Receiving device capability information of the same user's device(s) and/or other user's device(s)
  - Publishing device capability information to Presence Server, via SIP/IP Core
- Performing device presence information (including device online status, Content View selection information and Content Viewing Information) related functions
  - Subscribing device presence information of the same user's device(s) and/or other user's device(s)
  - Receiving device presence information of the same user's device(s) and/or other user's device(s)
  - Publishing device presence information to ISC Server
- Receiving media contents to the ISC User's device

- Fetching list of contents (including metadata) from the ISC Server based on access rights and allowed searching criteria (such as content name, content identifier, pre-defined keyword, bookmarks, content tags, viewed/viewing content, rating comment) in a service provider's domain. The possible contents are:
  - contents (live/non-live) from the Content Provider,
  - user generated contents (live/non-live), and
  - preview of content(s),
- Fetching the list of Associated Contents related to the Primary Content from the ISC Server.
- Searching for ISC Users based on allowed criteria for content (such as content name, content identifier, pre-defined keyword, bookmarks, content tags, viewed/viewing content, rating comment) in a service provider's domain
- Managing (e.g. viewing, storing and sharing) resources including the viewed Primary Content (live/non-live), Content Viewing Information, information (e.g. metadata, bookmarks, content tags) related to the viewing/viewed content, communication information (e.g. list of ISC Users communicating while watching the same content), Associated Contents, and user generated contents (live/non-live) retrieved from the ISC Server or other ISC Clients.
- Managing the ISC User Preferences information
- Managing the established communication session (e.g. manage floor control)
- Generating communication (e.g. voice/video call with a presenter or participants in a TV show)

The ISC Client SHALL support the following functionalities related to the social interaction:

- Requesting social activity (e.g. send invitation, request to join, content sharing)
- Generating and receiving unidirectional/bidirectional social interaction request(Provider (e.g. transmitting vote of the ISC User to the presenter of a TV show)
- Sending the delegating of ISC User's content viewing rights to other ISC Server
- Receiving other ISC User's presence information (e.g. available/not available for content viewing)
- Requesting to establish a social relationship (e.g. setting up the ISC User as 'colleague', 'friend' etc)
- Requesting to share information related to the ISC User's experience with content (such as interest to watch a content, watched a content, bookmarks, content tags, comments of the viewing/viewed content)
- Receiving shared information related to other ISC User(s) experience with content (e.g., interest to watch a content, bookmarks, content tags, ISC User published live/non-live audio/videos, comments)
- Requesting to establish (non-real-time) communication channel via the service provider to allow other ISC Users to communicate with e.g., ISC User can create a new topic to receive ISC User comments.
- Requesting to express interest (e.g., Like) on a comment and/or content provided by the service provider or other ISC User(s).
- Providing feedback to the content viewed such as a rating and comment.

The ISC Client SHALL support the following functionalities related to the immersive experience:

- Sending Spatial Configuration information to the ISC Server
- Sending selection of Content View or Continuous Content View by the ISC User
- Receiving Content Views and Continuous Content Views from the ISC Server

The ISC Client SHALL support the following functionalities related to the multi-device supporting:

- Discovering and exposing capabilities of ISC User's device(s)
- Managing content viewing and communication of ISC User's multi-devices
- Synchronizing Content Viewing Information between multi-devices of the same ISC User

- Sharing the content metadata and/or Associated Content information between ISC User's device(s)
- Delivering media contents to one or more of ISC User's devices based on device capabilities

The ISC Client SHALL support the following media plane communication related functionalities:

- Establishing and maintaining media plane connections
- Generating and receiving media plane requests and responses

## 5.3.2 ISC Server

The ISC Server is composed of several logical functions to support contents guide formatting and filtering, Associated Contents binding with Primary Content, content storage and management, multiple devices handling, Content Viewing and Communication session handling, contents distribution, social interactions.

The ISC Server also handles ISC Client registration, ensures data integrity and confidentiality and user privacy. The ISC Server is responsible for authorization and authentication of all the requests coming from or terminating into ISC Client.

The ISC Server SHALL support the functionalities as described in sections 5.3.2.1 to 5.3.2.7.

### 5.3.2.1 Contents Guide Function

The Contents Guide Function is responsible to provide personalized (based on user context and preferences) list of contents (including metadata) such as Content Provider contents (live/non-live), user generated contents (live/non-live), and Associated Contents.

The Content Guide Function SHALL support the following functionalities:

- Providing part/full list of contents
- Sorting of list of available contents as per ISC User specified criteria
- Searching contents in the contents list
- Personalization of contents list based on user context and preferences
- Synchronization of contents list with the content provider
- Management (for e.g., removing from availability list, access control list, categorization) of contents
- Generating Primary Contents list matched with the collected Content Viewing Information

Based on the type of contents list request from the ISC Client, the list of contents includes:

- Content Provider contents (live and non-live)
- Associated Contents
- User generated contents (live and non-live)

The Contents Guide Function interacts with other components of the ISC Server:

- Multi-device Discovery Function to access the Content Viewing Information (e.g., content metadata and viewing progress) of the Primary Content, multi-device capability information of the ISC User(s) and provide the customized list of contents and Associated Contents suitable to device capabilities
- Associated Contents Function for fetching Associated Contents (including metadata) related to the Primary Content e.g. based on the collected Content Viewing Information
- Storage Function to get list of contents (including metadata) and/or preview of the content(s)

The Contents Guide Function interacts with other network components such as:

- ISC XDMS (via XDM Agent) to fetch user preferences

- ISC XDMS to subscribe and receive the full list of contents (including Associated Contents) from the ISC Content Provider(s) via ISC CP Gateway.

### 5.3.2.2 Associated Content Function

The Associated Content Function SHALL support the following functionalities:

- Searching relevant Associated Contents
- Personalization of Associated Contents based on user context and preferences (e.g. type of Associated Content such as audio, video, etc)
- Management (for e.g., removing from availability list, access control list, categorization) of the Associated Contents
- Maintains the associations between Primary Content and Associated Contents
- Provides Associated Contents based on the ISC User's selected Primary Content and the maintained associations

The Associated Contents Function interacts with other ISC network components such as:

- Contents Guide Function supplying Associated Contents list in relation to the Primary Content being delivered to the ISC Client.
- Media Function supplying Associated Contents (including metadata) in relation to the Primary Content being delivered to the ISC Client.

### 5.3.2.3 Communication Function (CPM Enabler Server-side functional components)

The Communication Function directly refers to CPM Enabler Server-side Functional Components to support interactions between ISC Users and the Content Providers and also among other ISC Users.

The Communication Function SHALL support the following functionalities:

- Performing Communication session handling (session initiation, modification and termination) related functions
- Performing policy enforcement in Communication session according to the service provider policies and group policies, where applicable.
- Maintaining binding information of Communication session
- Providing SDP negotiation for Communication
- Providing support for simultaneous sessions for Communication
- Standalone messages and chat messages distribution handling
- Maintains integration information of communication (with 1-1 and 1-many) sessions
- Providing distribution of communication media to ISC User's multiple devices according to spatial configuration
- Supporting multiple devices handling based on media characteristics, device capabilities
- Storing of Communication history based on ISC User preferences and service provider policies
- Maintaining Communication Information regarding ISC User's multiple devices involved in communication information
- Managing the established communication session (e.g. manage floor control)

The Communication Function interacts with other ISC network components such as:

- XDM Enabler for the retrieval of user preferences, groups information and service provider policies
- ISC Server Social Function and Multi-device Discovery Function acting as Presence Enabler for publish communication information in 1-1 and 1-many sessions, between multi-devices when communication being distributed on different devices

- ISC Client for receiving
  - request to store (whole or parts of) the ISC User's communication information

### 5.3.2.4 Media Function

The Media Function SHALL support the following functionalities:

- Generates recommendation of spatial distribution according to the Content and Communication media identified to distribute and the devices discovered
- Providing centralized mixing of contents (Primary Content, Associated Content) based on spatial configuration of devices and multi-device capabilities
- Performing Content Viewing session handling (session initiation, modification and termination) related functions
- Performing policy enforcement in Content Viewing session according to the service provider policies and group policies, where applicable.
- Maintaining binding information of Content Viewing session
- Providing SDP negotiation for Content Viewing
- Providing support for multiple contents in Contents Viewing session
- Providing support for simultaneous sessions for Content Viewing
- Maintains integration information of content viewing (with 1-1 and 1-many) sessions
- Generates the Content Viewing Group information
- Generates the Content View information for sharing to other ISC Users
- Providing distribution of content media streams to ISC User's multiple devices according to spatial configuration
- Provides support for synchronizing the Content Viewing between ISC Users
- Supporting multiple devices handling based on media characteristics, device capabilities
- Storing of Content Viewing history based on ISC User preferences and service provider policies
- Sharing whole or parts of content and/or references to whole or parts of content from stored contents
- Provides support for a content to be delivered at a later time

The Media Function interacts with other ISC network components such as:

- Multi-device Discovery Function to know the spatial configuration of devices and capabilities and to access the Content Viewing Information e.g. content metadata and viewing progress of the Primary Content.
- Communication Function to know the ISC User selected spatial configuration
- ISC CP Gateway Contents Function to fetch the content for mixing
- Associated Contents Function to fetch ISC User selected contents related to Primary Content being viewed
- ISC Client for receiving
  - request to store (whole or parts of) the contents (Primary Content and Associated Content) being watched together
  - request to (start, stop) synchronizing Content Views between ISC Users
  - request to control (pause, resume) functions to the content being watched

The Media Function interacts with other network components such as:

- the Push Enabler to send notification to ISC Client about potential list of Associated Contents, Users watching similar contents, watched similar content before, alert signal before the distribution of the content starts) and



- the Content Provider component via Interaction Function of ISC CP Gateway for non-realtime communication, registration of content interest.

### 5.3.2.5 Storage Function

The Storage Function enables the ISC Client to store and manage communication-related content, and different type of contents including the viewing/viewed contents, user generated contents (live/non-live), and Associated Contents.

The Storage Function SHALL support the following functionalities:

- Providing list of contents available on storage
- Folder management
- Synchronization of contents of the ISC Client's local storage including synchronization management under scenarios with multiple Devices, according to the ISC User's preferences and/or the service provider's policy
- Storing and managing (retrieve, delete, share, add metadata information, etc) the viewed contents (Primary Content and Associated Contents) and user generated contents according to authorized ISC User's request and/or preferences
- Storing and managing (retrieve, delete, share, etc) the viewed contents (Primary Content and Associated Contents), user generated contents and Content Viewing Information according to authorized ISC User's request and/or preferences
- Managing (e.g. create, modify, delete) information (e.g. metadata, bookmarks, content tags) related to the viewing/viewed content according to authorized ISC User's request and/or preferences
- Support the ISC Client to search for content(s) and/or ISC User(s) based on allowed criteria (such as content name, content identifier, pre-defined keyword, bookmarks, content tags, viewed/viewing content, rating comment)

Based on the request from the ISC Client, the list of contents that an authorized ISC User can store includes:

- Content Provider contents (live and non-live)
- Associated Contents
- User-generated contents (live and non-live)
- Communication contents

The Storage Function interacts with other ISC components such as:

- ISC Client to store and manage (retrieve, delete, share, etc) contents and folders
- ISC Client to manage (create, modify, delete) metadata information to the stored content
- Communication Function and Media Function allowing them to store history of contents viewed

### 5.3.2.6 Multi-device Discovery Function

The Multi-device Discovery Function acts as a Presence Enabler's server-side functional components, Presence Server, for managing the Device Presence Information.

The Multi-device Discovery Function SHALL support the following functionalities:

- Supporting device capability information related functions,
  - Receiving and managing the published device capability information from ISC Client.
  - Processing subscription on device capability information from ISC Client.
  - Sending subscribed device capability information to subscriber.
- Supporting device presence information (including device online status, Content View selection information and Content Viewing Information) related functions,

- Receiving and managing the published device online status (belonging to device presence information) from ISC Client.
- Processing subscription on device presence information from ISC Client.
- Sending subscribed device presence information to subscriber.
- Receiving and managing (e.g. storing, updating, providing) the published device presence information to/from ISC Client.
- Supporting multi-device task management related functions,
  - Receiving and managing information for future resuming content viewing from one of the ISC User's devices.
  - Providing stored information for future resuming content viewing to one of the ISC User's devices.
  - Upon receiving the ISC User's request (initiator and/or recipient), distributing the communication task and content viewing task to the user different device(s), according to the service policy and the devices capabilities.

### 5.3.2.7 Social Function

The Social Function acts as Presence Enabler server-side functional components and SHALL support the following functionalities:

- Generates recommendation of spatial distribution according to the Content and Communication media identified to distribute and the devices discovered
- Generates recommendation of content for social activity e.g., monitor friends Content Viewing and recommend to one, two or group of ISC Users
- Publishes social activity information
- Generates notification for change in Content Views

The Social Function interacts with other ISC network components such as:

- ISC Client
  - to define social relationship with contacts
  - to share information related to his/her experience with content (such as interest to watch a content, watched a content, bookmarks, content tags, comments of the viewing/viewed content)

### 5.3.3 ISC XDMS(s)

The ISC XDMS(s) are server entities as described in [OMA-XDM-AD] sub clause 5.3.1.6. ISC XDMS(s) are an ISC Enabler Specific XMDS(s) (see [OMA-XDM-AD], sub clause 5.3.1.12), and specifies the following list of Application Usages which are logical in nature and may be implemented as one or more server-side entities.

#### 5.3.3.1 ISC User Preferences Application Usage

The ISC User Preferences Application Usage represents the network repository for the user preferences data and it SHALL support the following functions:

- Document Management as described in [OMA-XDM-AD] sub clause 5.3.1.6.1;
- Subscription and Notification of user preferences document changes as described in [OMA-XDM-AD] sub clause 5.3.1.6.2;
- Access Permissions as described in [OMA-XDM-AD] sub clause 5.3.1.6.3;

## 5.3.4 ISC CP Gateway

The ISC CP Gateway provides interface(s) to connect to the Content Provider component, and the ISC CP Gateway which has two functional components, Content Function and Interaction Function.

### 5.3.4.1 Interaction Function

The Interaction Function of the ISC CP Gateway allows ISC Client(s) via ISC Server to establish realtime and no-realtime communication with Content Provider component including receiving request for interested content, content rating, vote, etc.

The Interaction Function of the ISC CP Gateway SHALL support the following functionalities:

- For communication session handling:
  - Forwarding communication session initiation, modification and termination requests to/from the Content Provider component for:
    - voice call and/or
    - messaging
- For social interaction handling:
  - Supporting unidirectional or bidirectional social interaction between the ISC Client and the ISCPGateway via the ISC Server
  - Forwarding the request from the Content Provider component to the ISC Server to initialize a social interaction with the ISC Users.
  - Forwarding invitation to the Content Provider component to join a social interaction by the ISC Server.
  - Forwarding the result of a social interaction from the ISC Server to the Content Provider component, if requested.

### 5.3.4.2 Contents Function

The Contents Function of the ISC CP Gateway allows the authorized ISC Server to retrieve media contents and associated information (such as contents list, contents, associated contents) from the Content Provider component.

The Contents Function of ISC CP Gateway SHALL support the following functionalities:

- Providing media contents of Content Views and Continuous Content Views to the ISC Server
- Receiving subscription for contents list updates
- Providing Content list updates to the ISC Server and ISC XDMS

## 5.3.5 External Functional Components

### 5.3.5.1 SIP/IP Core

The SIP/IP core includes a number of SIP proxies and SIP registrars as defined in [RFC3261]. The SIP/IP core performs the following functions that are needed to support the ISC Enabler:

- Routing the SIP signaling.
- Providing address resolution services.
- May provide charging information.
- Providing SIP compression.
- Performing authentication and authorization of the ISC User at the ISC Client based on the user's service subscription.

- Providing and maintaining registration of ISC Clients and their associated ISC User Address(es) and device identifier.
- Providing support for the ISC User Address anonymity in the SIP signaling as described in [RFC3325].
- Providing list of registered devices and their capabilities.
- Providing support for NAT traversal
- Providing support for management of the ISC Server's subscriptions about the clients' registration information according to [RFC3680] and [RFC5628].

When the SIP/IP core is based on the 3GPP IMS or 3GPP2 MMD, the SIP/IP core architecture is specified in 3GPP [3GPP TS23.228] or 3GPP2 [3GPP2 X.S0013-002], respectively.

### 5.3.5.2 Converged IP Messaging (CPM) Enabler

The CPM Enabler can perform the following functions that are needed for the support of the ISC Enabler:

- Communication activity between ISC Users (e.g. send invitation, request to join, content sharing)
- Interaction between the ISC User and the Content Provider (e.g. transmitting vote of the ISC User to the presenter of a TV show)
- Management of Content Viewing Group participants (e.g. inviting participants, removing participants, processing join requests, and setting group policy)
- Activities related to participation in a Content Viewing Group (e.g. accept invitation to join into the group, initiate request to join into the group, join into and/or leave from the group)

The functionalities provided by the CPM Enabler are as described in [OMA-CPM-AD].

### 5.3.5.3 XML Document Management Enabler

The XDM Enabler allows users and other Enablers to store and manage XML documents [OMA-XDM-AD]. The functionalities provided by the XDM Enabler are specified in [OMA-XDM-AD].

For the ISC Enabler, the XDM Enabler provides XDM operations for:

- ISC User Preferences Profiles
- ISC User preferences
- access policies
- user lists
- group definitions
- service policy
- list of contents and Associated Contents

The ISC functional components interact with the XDM Enabler via the XDM-4i interface.

### 5.3.5.4 CAB Enabler

The CAB Enabler allows users and other Enablers to store and manage Address Book XML documents [OMA-CAB-AD]. The functionalities provided by the CAB Enabler are specified in [OMA-CAB-AD].

For the ISC Enabler, the CAB Enabler provides Address Book management operations for:

- To update ISC User's address book with Content Viewing Information and communication information.

### 5.3.5.5 Presence Enabler

The Presence Enabler provides ISC Users with the possibility to publish and retrieve Presence Information. It also allows ISC Users to obtain the Presence Information (e.g. available/not available for content viewing) of other ISC Users. The functionalities provided by the Presence Enabler are specified in [OMA-PRS-AD].

The ISC Server Social Function supports the functionalities of the Presence Enabler to obtain Presence Information and the ISC Server Multi-device Discovery Function supports the functionalities of the Presence Enabler to manage the device presence information.

The ISC Client acts as Watcher to subscribe and receive itself and/or other ISC User's Presence Information, and acts as Presence Source to publish itself Presence Information. The ISC Client interacts with the ISC Server Social Function and Multi-device Discovery Function via the PRS-1 and PRS-2 reference points defined by the Presence Enabler.

### 5.3.5.6 Push Enabler

The Push Enabler performs the following function to support the ISC Enabler:

- Delivery of notifications (e.g. alert about the start of a program) towards the Device(s) of the ISC User.
- Delivery of notifications (e.g. alert about voting result) towards the Content Provider component.

The functionalities provided by the Push Enabler are as described in [OMA-PUSH-AD].

The ISC Server interacts with the Push Server via the Push Access Protocol (PAP) reference point defined by the Push Enabler.

The ISC Client interacts with the Push Client via the Push-CAI interface defined by the Push Enabler.

### 5.3.5.7 DM Enabler

The interaction between the ISC Client and the DM Client as an external entity SHALL enable the following supporting functions:

- Receive the initial parameters needed for ISC Service sent by service provider by using mechanisms specified in [OMA-DM-PRO].
- Retrieve and update the parameters needed for ISC Client sent by a service provider by using [OMA-DM-PRO].

The interaction between the ISC Server and the DM server as an external entity SHALL enable the following supporting functions:

- Initialization and updating of all the configuration parameters necessary for the ISC Client.
- Software update for terminals allowing ISC Client upgrade.

The detailed description of the functionalities is given in [OMA-DM-PRO].

### 5.3.5.8 Remote ISC Environment

The Remote ISC Environment is the ISC environment residing in another (remote) network.

This Remote ISC Environment is a mirror of the environment described in this document, and can contain the full set of ISC functional components described in this document or a subset thereof.

The ISC Enabler interacts with the Remote ISC Environment to allow ISC Users of the local ISC environment to interact with ISC Users of the other (remote) network.

### 5.3.5.9 Content Provider Component

The Content Provider component is a logical component which supports the functionalities of realtime and no-realtime communication (including unidirectional/bidirectional social interaction) between the ISC User(s) and the Content Provider, via the ISC CP Gateway and the Supporting Enabler(s).

The Content Provider component also provides media contents and associated information (such as contents list, contents, associated contents) to the authorized ISC Server(s) via the ISC CP Gateway and the Supporting Enabler(s).

## 5.3.6 Interfaces

### 5.3.6.1 ISC-1

The ISC-1 interface is exposed by the ISC Server to allow the authorized ISC Client(s) to access/trigger the functionalities of the ISC Server.

The ISC-1 interface SHALL support the following functionalities:

- ISC communication session signalling management (initiation, modification, termination)
- ISC content viewing session signalling management (initiation, modification, termination)
- Management of the ISC content viewing session
- Multi-device task management
- Media transfer pertaining to a Content View
- Control of Media transfers in a Content View
- Delivery of
  - contents list,
  - live media (Content Provider provided contents, User Generated Contents and social interaction),
  - stored media
  - Content Viewing Group
  - Notifications
  - non-live media
  - Associated Contents
- Management of the ISC User's stored contents (e.g. folder management, object management)
- Authentication and authorization of the ISC User

### 5.3.6.2 ISC-2

The ISC-2 interface is exposed by the ISC Server to allow the Content Provider to trigger communication session with the ISC Client(s) via the ISC Server and the ISC CP Gateway.

Supported functionalities include:

- Forwarding communication session (voice call, video call, or messaging) initiation and termination requests to/from the Content Provider.

### 5.3.6.3 ISC-3

The ISC-3 interface is exposed by the ISC CP Gateway to allow the authorized ISC Server to establish ISC session to retrieve Content Provider's Content Views (also including Continuous Content Views and Associated Contents) and relevant information (such as contents list, and content metadata) from the Content Provider.

Supported functionalities include:

- Forwarding real-time media delivery session initiation, modification and termination requests to the Content Provider.
- Providing the media contents and related information from the Content Provider to the ISC Server via the established ISC session.

### 5.3.6.4 ISC-4

The ISC-4 interface is exposed by the ISC Server to allow the other network-side functional components (such as another ISC Server in a remote ISC environment) to access / trigger the functionalities of the ISC Server.

The ISC-4 interface SHALL support the following functionalities:

- Forwarding of communication signalling (initiation, termination)
  - For communication between the Content Provider and the ISC User(s);
  - For communication among the ISC Users
- Forwarding of ISC content viewing session signalling (initiation, modification, and termination).
- Notifications (e.g. for Content Viewing Information, participants information) exchanged between the ISC Servers.
- Media contents and related information (e.g. for Content Views and Associated Contents) exchanged between the ISC Servers.

### 5.3.6.5 XDM-4i

The XDM-4i interface is exposed by the ISC XDMS to allow ISC Server (with XDM Agent) in the same network to access/manage the network repository resources stored in the ISC XDMS.

The XDM-4i interface SHALL support the following functionalities for the ISC Server:

- Management of ISC User Preferences Document (e.g. create, modify, retrieve, delete) handled by ISC XDMS(s).
- Management of pre-defined Content Viewing Group (e.g. create, modify, retrieve, delete, search) handled by ISC XDMS(s).
- Management of content list of Content Views and Associated Contents (e.g. create, modify, retrieve, delete, search) handled by ISC XDMS(s).

## 5.3.7 External Interfaces

### 5.3.7.1 XDM-4i

The XDM-4i interface is exposed by the ISC XDMS to allow the other network-side functional components (such as XDM Agent) to access / trigger the functionalities of the ISC Server. The XDM-4i interface is described in [OMA-XDM-AD].

The XDM-4i interface provides the following functionalities:

- Management of ISC User Preferences Document (e.g. create, modify, retrieve, delete) handled by ISC XDMS(s) residing in the same network as the XDM Agent.

The XDM-4i interface SHALL provide the following functionalities for the interaction between ISC XDMS and ISC CP Gateway and between ISC XDMS and ISC Server

- Receiving Contents List request from the ISC Server Contents Guide Function.
- Provide the Contents List document to ISC Server Contents Guide Function.
- Subscribing for Contents List updates.
- Handling of subscription request from ISC Server Contents Guide Function for receiving the Contents List updates.
- Storage of Contents List Schema in ISC XDMS
- Storing and fetching ISC Pre-defined group members list and policies in ISC XDMS.
- Interaction with the ISC Server components.
- Storing and fetching of ISC User's preferences for Content's list management.

- To receive the Contents List from ISC CP Gateway.
- To receive the Contents List updates from the Content Providers via ISC CP Gateway.

## 5.4 Security Considerations

### 5.4.1 Authentication

Mutual authentication between ISC Server and ISC Client is expected on the interface ISC-1 as a prerequisite to authorization, described in section 5.4.2. After mutual authentication, the key shared between ISC Server and ISC Client will be obtained and used for confidentiality and integrity for data transportation, described in 5.4.3.

ISC Server shall authenticate ISC Client based on one of the following mechanisms:

- username and password;
- authentic user information provided by underlying trusted network;
  - ISC Server uses the authentic user information (e.g., subscriber identifier, keys negotiated between the user and network after network access authentication) as credentials;
- certificates

As for the first two mechanisms described above, TLS in [OMA SEC\_CF-V1\_1] should be used when sending requests using password authentication or authentic user information authentication.

ISC Client shall authenticate ISC Server based on certificates.

Mutual authentication between ISC Server and Content Provider, which is expected on interfaces ISC-2 and ISC-3, is subject to service provider policy. The possible mechanisms are available in [OMA SEC\_CF-V1\_1].

### 5.4.2 Authorization

ISC Servers support at least one of the following authorization mechanisms:

- black/white list;
- access control list.

ISC Servers support ISC Users define their own authorization rules according to above mechanisms.

With authorization mechanisms, ISC Users can

- authorize other ISC Users to perform the action(s) their requested;
- authorize other ISC Users to access their contents/information stored in the network according to their rules.

### 5.4.3 Confidentiality and Integrity

After mutual authentication between ISC Server and ISC Client, shared keys will be obtained and used for:

- Confidentiality and integrity for users information/interaction transportation, possible mechanisms are available in [OMA SEC\_CF-V1\_1];
- Confidentiality for content transportation over protocols (e.g., HTTP, RTP), possible mechanisms are available in [OMA SEC\_CF-V1\_1] or in [RFC3711].

Confidentiality and integrity for data transportation between ISC Server and Content Provider, is subject to service provider policy. The possible mechanisms are available in [OMA SEC\_CF-V1\_1] or in [RFC3711].



## 5.5 Charging Considerations

The ISC Enabler may need to support the receiving of charging data or charging events triggered from an external mechanism in order to fulfil the charging requirements described in [OMA-ISC-RD]. One such mechanism is triggering through the OMA Charging Enabler.

The OMA Charging Enabler [OMA-CHG-AD] coordinates charging data triggers and flows from OMA ISC Enabler into an underlying charging infrastructure, supporting charging mechanisms for various business models.

Functional components that may optionally report Chargeable Events are:

- ISC Server

The interaction between these functional entities and the OMA Charging Enabler is described in [OMA-CHG-AD]. Description of how charging is performed is beyond the scope of the present specification.

## Appendix A. Change History

(Informative)

### A.1 Approved Version History

Reference	Date	Description
OMA-AD-ISC-V1_0-20150630-A	30 Jun 2015	Status changed to Approved by TP TP Ref # OMA-TP-2015-0116-INP_ISC_V1_0_ERP_for_final_Approval

## Appendix B. Flows (informative)

### B.1 Synchronization of Content Viewing

The flows in this section depict examples of synchronization of content viewing between the ISC Clients of the same ISC User or different ISC User in the multi-device environment.

#### B.1.1 1-1 Content Viewing Synchronization between the ISC Clients

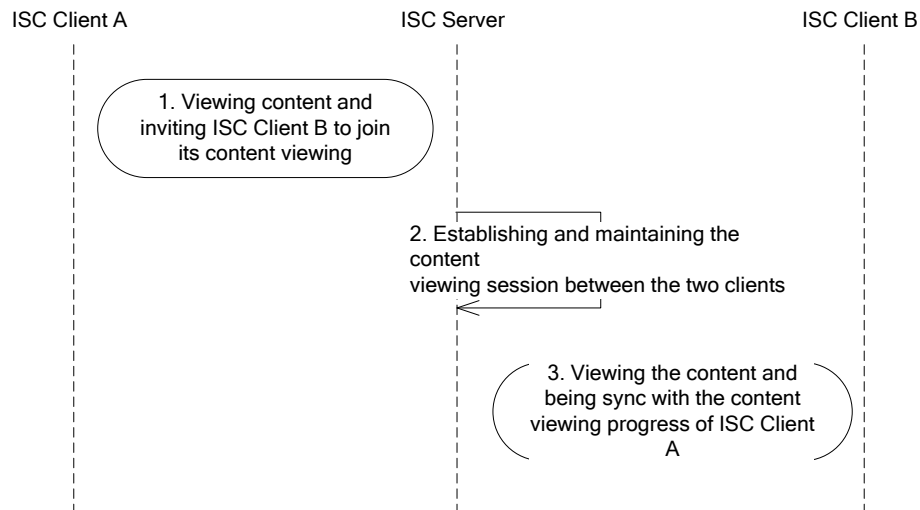

**Figure 3: 1-1Synchronization of Content Viewing**

The above figure shows the ISC Client B synchronizes the content viewing of the ISC Client A via the ISC Server, The major steps include:

1. When the ISC Client A is viewing media content, it can request to invite the ISC Client B joining into its content viewing. The request is sent to ISC Client B via ISC Server.
2. Upon receiving the request of the ISC Client A, the ISC Server, if allowed, establishes an ISC content viewing session for the ISC Client A and B. The ISC Server, through the content viewing session, retrieves media contents according to selections of the ISC Client A and B from Content Provider and sends the media contents to ISC Client A and B respectively with the same playback progress.
3. The ISC Client B accepts the invite of ISC Client A and joins the ISC content viewing session above. Through the content viewing session, the ISC Client B receives the media content and be sync with the content viewing progress of the Client A.

In the above flow, the ISC Client A and the ISC Client B can belong to one ISC User, or different ISC Users.

## B.1.2 1-N Content Viewing Synchronization in Content Viewing Group

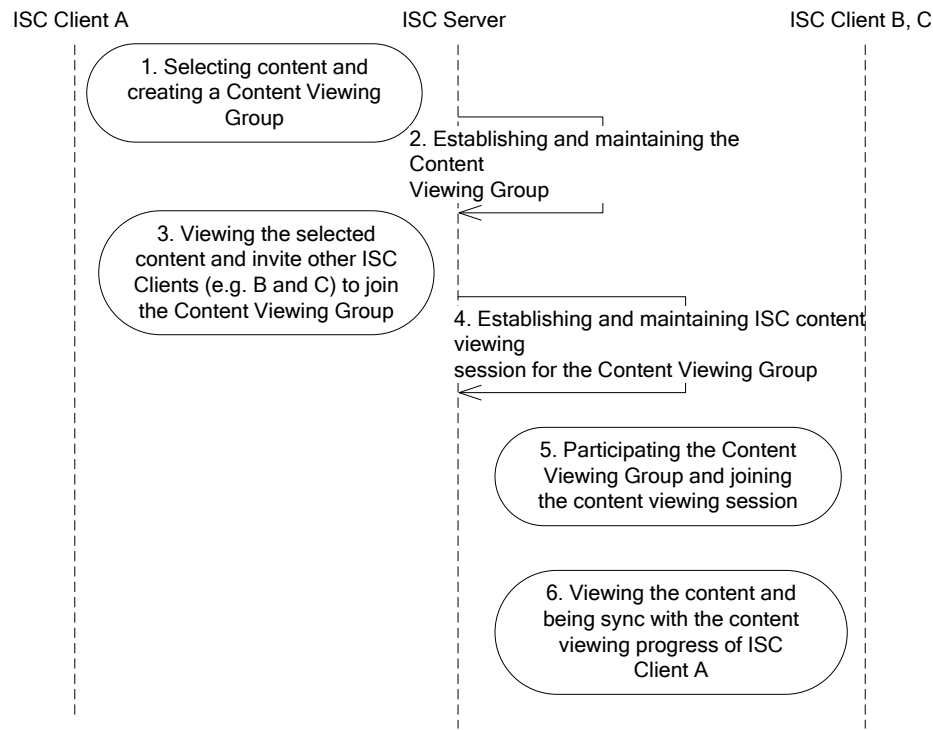

**Figure 4: 1-N Synchronization of Content Viewing in Content Viewing Group**

The above figure shows ISC Clients in a Content Viewing Group (e.g. ISC Client B and/or ISC Client C) synchronize the Content Viewing with the ISC Client A via the ISC Server, The major steps include:

1. Upon receiving the request of the ISC User A, the ISC Client A requests to create a Content Viewing Group on the ISC Server, based on selected media content.
2. The ISC Server creates a Content Viewing Group according to request of the ISC Client A, and maintains the Content Viewing Group.
3. The ISC Client A request to render the selected media content in the Content Viewing Group, and invites the ISC Client B and C to join the Content Viewing Group.
4. Upon receiving the request of the ISC Client A, the ISC Server establishes and maintains a content viewing session for the Content Viewing Group, and the ISC Server forwards the joining invite to the ISC Client B and C.
5. Upon receiving the consent from the ISC User B and C, the ISC Client B and C accept the joining invite from ISC Client A, and participate into the Content Viewing Group, and joins in the content viewing session.
6. The ISC Client B and C accept the invite of ISC Client A and joins the ISC content viewing session above. Through the content viewing session, the ISC Client B and C receive the media content and be sync with the content viewing progress in the Content Viewing Group.

In the above flow, the ISC Client A, B and C can belong to one ISC User, or different ISC Users.

## B.2 Communication

The flows in this section show examples of communication handling between the ISC Users, and between the ISC User and the Content Provider.

### B.2.1 Communication between the ISC Users

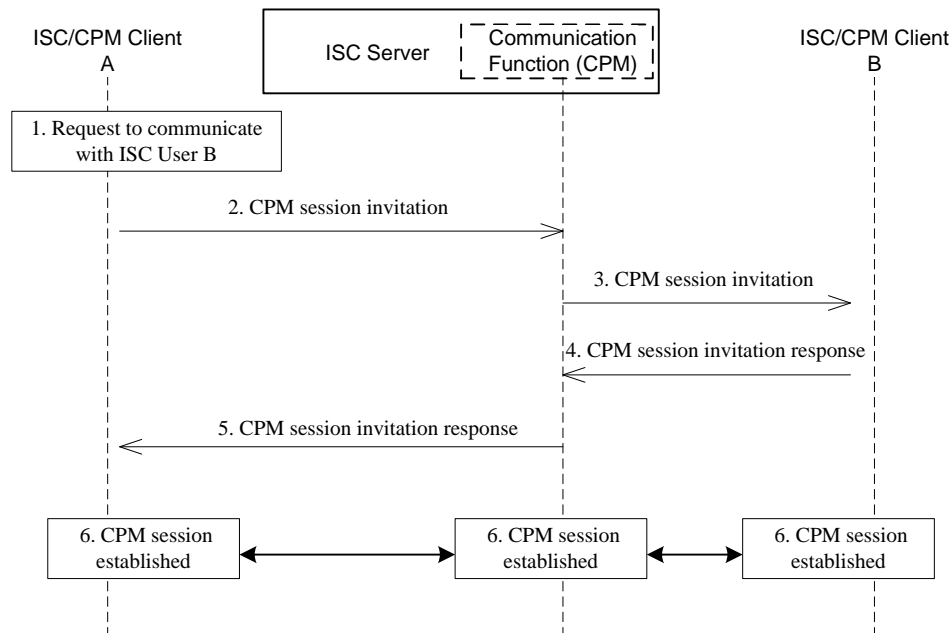

**Figure 5: Communication between the ISC Users**

The above figure shows the ISC User A and the ISC User B communicate with each other via the ISC Enabler and the CPM Enabler. The major steps include:

1. The ISC User requests the ISC/CPM Client A to communicate with ISC User B.
2. The ISC/CPM Client A sends CPM session invitation to the Communication Function (CPM).
3. The Communication Function (CPM) forwards the CPM session invitation to the ISC/CPM Client B of the ISC User B.
4. The ISC/CPM Client B responds the CPM session invitation.
5. The Communication Function (CPM) forwards the response to the ISC/CPM Client A.
6. The CPM session will be established between the ISC/CPM Client A, the ISC/CPM Client B, and the Communication Function (CPM).

In the above flow, the ISC User A and the ISC User B are also CPM Users.

### B.2.2 Communication between the ISC User and the Content Provider

It's similar to support the communication between the ISC User and the Content Provider. On this scenario, the Content Provider similarly acts as the ISC User B.

## Appendix C. Additional Information (Informative)

### C.1 ISC Interactions with Supporting Enablers

The following figure contains additional information to Figure 2, showing the main interfaces of each Enabler (the ISC Enabler and the supporting Enablers) from the ISC Enabler's perspective, as well as the interfaces between Enablers.

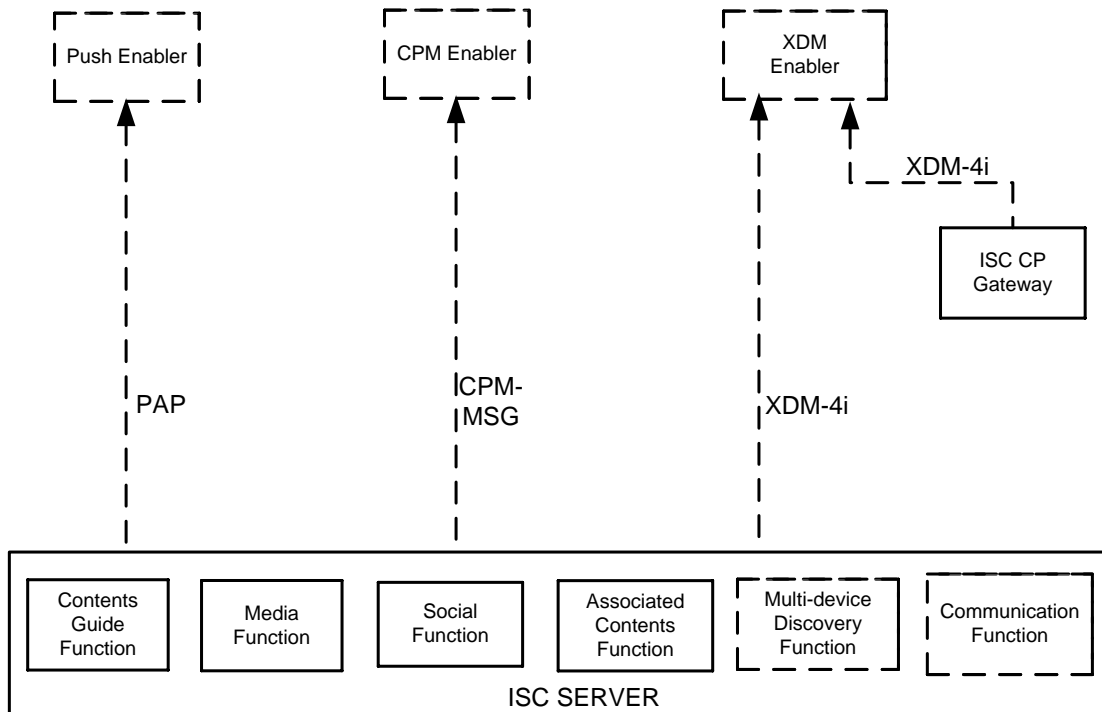

Figure 6: Interactions between the ISC Server functional components and the supporting Enablers

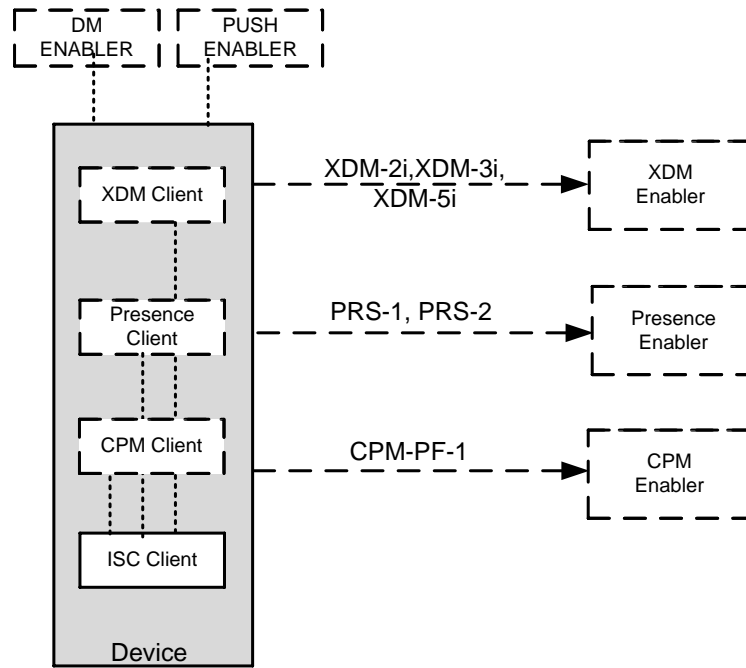

Figure 7: Interactions between the ISC Enabled Device and the supporting Enablers