



NGSI Call Control and Configuration

Approved Version 1.0 – 29 May 2012

Open Mobile Alliance
OMA-TS-NGSI_Call_Control_and_Configuration-V1_0-20120529-A

Use of this document is subject to all of the terms and conditions of the Use Agreement located at <http://www.openmobilealliance.org/UseAgreement.html>.

Unless this document is clearly designated as an approved specification, this document is a work in process, is not an approved Open Mobile Alliance™ specification, and is subject to revision or removal without notice.

You may use this document or any part of the document for internal or educational purposes only, provided you do not modify, edit or take out of context the information in this document in any manner. Information contained in this document may be used, at your sole risk, for any purposes. You may not use this document in any other manner without the prior written permission of the Open Mobile Alliance. The Open Mobile Alliance authorizes you to copy this document, provided that you retain all copyright and other proprietary notices contained in the original materials on any copies of the materials and that you comply strictly with these terms. This copyright permission does not constitute an endorsement of the products or services. The Open Mobile Alliance assumes no responsibility for errors or omissions in this document.

Each Open Mobile Alliance member has agreed to use reasonable endeavors to inform the Open Mobile Alliance in a timely manner of Essential IPR as it becomes aware that the Essential IPR is related to the prepared or published specification. However, the members do not have an obligation to conduct IPR searches. The declared Essential IPR is publicly available to members and non-members of the Open Mobile Alliance and may be found on the “OMA IPR Declarations” list at <http://www.openmobilealliance.org/ipr.html>. The Open Mobile Alliance has not conducted an independent IPR review of this document and the information contained herein, and makes no representations or warranties regarding third party IPR, including without limitation patents, copyrights or trade secret rights. This document may contain inventions for which you must obtain licenses from third parties before making, using or selling the inventions. Defined terms above are set forth in the schedule to the Open Mobile Alliance Application Form.

NO REPRESENTATIONS OR WARRANTIES (WHETHER EXPRESS OR IMPLIED) ARE MADE BY THE OPEN MOBILE ALLIANCE OR ANY OPEN MOBILE ALLIANCE MEMBER OR ITS AFFILIATES REGARDING ANY OF THE IPR'S REPRESENTED ON THE “OMA IPR DECLARATIONS” LIST, INCLUDING, BUT NOT LIMITED TO THE ACCURACY, COMPLETENESS, VALIDITY OR RELEVANCE OF THE INFORMATION OR WHETHER OR NOT SUCH RIGHTS ARE ESSENTIAL OR NON-ESSENTIAL.

THE OPEN MOBILE ALLIANCE IS NOT LIABLE FOR AND HEREBY DISCLAIMS ANY DIRECT, INDIRECT, PUNITIVE, SPECIAL, INCIDENTAL, CONSEQUENTIAL, OR EXEMPLARY DAMAGES ARISING OUT OF OR IN CONNECTION WITH THE USE OF DOCUMENTS AND THE INFORMATION CONTAINED IN THE DOCUMENTS.

© 2012 Open Mobile Alliance Ltd. All Rights Reserved.

Used with the permission of the Open Mobile Alliance Ltd. under the terms set forth above.

Contents

1. SCOPE	4
2. REFERENCES	5
2.1 NORMATIVE REFERENCES	5
2.2 INFORMATIVE REFERENCES	5
3. TERMINOLOGY AND CONVENTIONS	6
3.1 CONVENTIONS	6
3.2 DEFINITIONS	6
3.3 ABBREVIATIONS	6
4. INTRODUCTION	7
4.1 VERSION 1.0	7
4.1.1 Backward Compatibility to the Parlay Specifications.....	7
5. NGSI-4: TECHNICAL DETAILS	9
5.1 NGSI-4: CALL CONTROL EXTENSION INTERFACE	9
5.1.1 Service Description.....	9
5.1.2 Data Type Definition	9
5.1.3 Interface definition.....	9
5.1.4 Fault definitions	16
5.1.5 Alternative approaches (informative)	16
6. NGSI-5: TECHNICAL DETAILS	17
6.1 NGSI-5: CALL NOTIFICATION EXTENSION INTERFACE	17
6.1.1 Service Description.....	17
6.1.2 Sequence Diagrams.....	17
6.1.2.1 Simultaneous Call Forwarding.....	17
6.1.2.2 Chained Call Forwarding.....	18
6.1.3 Data Type Definition	19
6.1.4 Interface definition.....	21
6.1.5 Alternative approaches (informative)	21
7. NGSI-6: TECHNICAL DETAILS	22
7.1 NGSI-6: CALL HANDLING EXTENSION INTERFACE	22
7.1.1 Service Description.....	22
7.1.2 Data Type Definition	22
7.1.3 Interface definition.....	24
7.1.4 Fault definitions	31
8. NGSI-7: TECHNICAL DETAILS	32
8.1 NGSI-7: MULTIMEDIA CONFERENCE EXTENSION INTERFACE	32
8.1.1 Service Description.....	32
8.1.2 Data Type Definition	32
8.1.3 Interface definition.....	36
8.1.4 Fault definitions	43
APPENDIX A. CHANGE HISTORY (INFORMATIVE)	44
A.1 APPROVED VERSION HISTORY	44
APPENDIX B. STATIC CONFORMANCE REQUIREMENTS (NORMATIVE)	45
B.1 SCR FOR NGSI CALL CONTROL AND CONFIGURATION CLIENT	45
B.2 SCR FOR NGSI CALL CONTROL AND CONFIGURATION SERVER	45

Figures

Figure 1: Example Sequence Diagram of Simultaneous Call Forwarding	18
Figure 2: Example Sequence Diagram for Chained Call Forwarding	19

1. Scope

This document is the Technical Specification for the interfaces for Call Control and Configuration. According to the NGSI AD [NGSI-AD] the Call Control and Configuration component exposes the interfaces NGSI-4, NGSI-5, NGSI-6, and NGSI-7. This TS document specifies the extensions from NGSI enabler to the

- Call Common Ext as defined in [3GPP TS 29.199-1],
- Call Control as defined in [3GPP TS 29.199-2],
- Call Notification as defined in [3GPP TS 29.199-3],
- Call Handling as defined in [3GPP TS 29.199-10], and
- Multimedia Conferencing as defined in [3GPP TS 29.199-12].

NGSI v1.0 defines abstract interfaces. This technical specification builds the basis for the definition of binding technologies based on the abstract interface definitions given in the TS.

The TS is not basis for testing without a respective binding.

2. References

2.1 Normative References

- [3GPP TS 29.199-1] “Open Service Access (OSA) Parlay X web services; Part 1”, URL:<http://www.3gpp.org/>
- [3GPP TS 29.199-2] “Open Service Access (OSA) Parlay X web services; Part 2”, URL:<http://www.3gpp.org/>
- [3GPP TS 29.199-3] “Open Service Access (OSA) Parlay X web services; Part 3”, URL:<http://www.3gpp.org/>
- [3GPP TS 29.199-10] “Open Service Access (OSA) Parlay X web services; Part 10”, URL:<http://www.3gpp.org/>
- [3GPP TS 29.199-12] “Open Service Access (OSA) Parlay X web services; Part 12”, URL:<http://www.3gpp.org/>
- [3GPP TS 29.199-21] “Open Service Access (OSA) Parlay X web services; Part 21”, URL:<http://www.3gpp.org/>
- [NGSI-AD] “NGSI Architecture Document”, Open Mobile Alliance™, OMA-AD-NGSI-V1_0, URL:<http://www.openmobilealliance.org/>
- [NGSI-Common] “NGSI Common Definitions”, Open Mobile Alliance™, OMA-TS-NGSI_Common-V1_0, URL:<http://www.openmobilealliance.org/>
- [NGSI-RD] “NGSI Requirements”, Open Mobile Alliance™, OMA-RD-NGSI-V1_0, URL:<http://www.openmobilealliance.org/>
- [RFC2119] “Key words for use in RFCs to Indicate Requirement Levels”, S. Bradner, March 1997, URL:<http://www.ietf.org/rfc/rfc2119.txt>
- [RFC4234] “Augmented BNF for Syntax Specifications: ABNF”. D. Crocker, Ed., P. Overell. October 2005, URL:<http://www.ietf.org/rfc/rfc4234.txt>
- [RFC 4575] “A Session Initiation Protocol (SIP) Event Package for Conference State”, URL:<http://tools.ietf.org/>
- [SCRRULES] “SCR Rules and Procedures”, Open Mobile Alliance™, OMA-ORG-SCR_Rules_and_Procedures, URL:<http://www.openmobilealliance.org/>

2.2 Informative References

- [3GPP TS 29.199-11] “Open Service Access (OSA) Parlay X web services; Part 11”, URL:<http://www.3gpp.org/>
- [draft-ietf-xcon-ccmp-06] “Centralized Conferencing Manipulation Protocol”, URL: <http://tools.ietf.org/>
- [draft-ietf-xcon-examples-03] “Centralized Conferencing Manipulation Protocol (CCMP) Call Flow Examples”, URL: <http://tools.ietf.org/>
- [OMADICT] “Dictionary for OMA Specifications”, Version 2.7, Open Mobile Alliance™, OMA-ORG-Dictionary-Vx2_7, URL:<http://www.openmobilealliance.org/>

3. Terminology and Conventions

3.1 Conventions

The key words “MUST”, “MUST NOT”, “REQUIRED”, “SHALL”, “SHALL NOT”, “SHOULD”, “SHOULD NOT”, “RECOMMENDED”, “MAY”, and “OPTIONAL” in this document are to be interpreted as described in [RFC2119].

All sections and appendixes, except “Scope” and “Introduction”, are normative, unless they are explicitly indicated to be informative.

3.2 Definitions

The definitions of the OMA Dictionary [OMADICT] are valid for this document unless otherwise stated below. Additionally the definitions given in [3GPP TS.199-1] apply.

Communication Service see [NGSI-RD]

Find Me Service see [NGSI-RD]

3.3 Abbreviations

NGSI Next Generation Service Interfaces

OMA Open Mobile Alliance

OSA Open Service Access

URI Uniform Resource Identifier

URL Uniform Resource Locator

4. Introduction

Call Control and Configuration APIs as defined in OSA/Parlay [3GPP TS 29.199] Part 2, 3 10 and 12 provides interfaces in order to allow applications to utilize call control functionalities, receive call notifications, and use multimedia conferencing functionalities. The subsections below summarize the specified functions and link the interfaces to the respective OSA/Parlay TS specification parts.

This TS specification is part of the TS specifications for the NGSI enabler,

4.1 Version 1.0

The NGSI TS Call Control and Configuration document specifies the following functions [NGSI-AD]:

- NGSI-4:
 - add / modify a specific Media or a specific Media address (e.g. SIP-URI, TEL-URI, URL).
 - record a Call and retrieve the recorded Media of a Call
 - configure an application-defined Call handling method
- NGSI-5: in the case of an event notification:
 - Add/ modify a specific Media or a specific Media address (e.g. SIP-URI, TEL-URI, URL)
 - record a Call during an action
 - configure an application-defined Call handling method,
- NGSI-6: supports access to a rule based processing capability through a set of operations that allow definition of discrete rules, such as
 - Call establishment rules
 - Call handling rules
- NGSI-7:
 - Manage the Media address
 - Configure the participant specific Media address and its usage conditions
 - configure conference presentation preferences available through network side configuration
 - configure the application-specific authentication
 - Configure the recording one or more Media of a conference
 - Record/ retrieve one or more Media of a conference
 - Observe/ coach a conference
 - configuration of the conference control
 - add and control side/child conference,

4.1.1 Backward Compatibility to the Parlay Specifications

The NGSI-4 to 7 interface provides an extension to the service API provided by OSA/Parlay [3GPP 29.199-19]. The table below summarizes the dependencies and applied modifications.

NGSI-4 to 7 interface uses the data types as defined in the respective [3GPP 29.199-19] and [3GPP 29.199-1]. Additional data types are defined. The name space definition given in the [3GPP 29.199-19] specifications apply unchanged.

NGSI interfaces	3GPP OSA/Parlay Technical Specification
NGSI-4	Call Common Ext as defined in [3GPP TS 29.199-1] Call Control as defined in [3GPP TS 29.199-2],
NGSI-5	Call Common Ext as defined in [3GPP TS 29.199-1] Call Notifications as defined in [3GPP TS 29.199-3]
NGSI-6	Call Common Ext as defined in [3GPP TS 29.199-1] Call Handlingl as defined in [3GPP TS 29.199-10]
NGSI-7	Call Common Ext as defined in [3GPP TS 29.199-1] Multimedia Conferencing as defined in [3GPP TS 29.199-12]

5. NGSI-4: Technical Details

5.1 NGSI-4: Call Control extension Interface

5.1.1 Service Description

The NGSI-4 interface provides an extension to the service API related to 3rd party call control whose basic scenario, interface descriptions and operations is described in [3GPP 29.199-2].

NGSI-4 extends by providing functionality to configure the Media to be performed at specified condition during the call, recording the Media and configure the call handling method.

5.1.2 Data Type Definition

NGSI-4 interface uses the data type definition as defined in [3GPP 29.199-2], [3GPP 29.199-1] and [NGSI-Common].

5.1.3 Interface definition

5.1.3.1 Interface: ThirdPartyCall

NGSI-4 interface specifies call enhancement functionalities to the ThirdPartyCall interface defined in [3GPP 29.199-2] as follows:

- *MakeCallSession* operation is extended by optional parameters, *RingbackMedia*, *AlertingMedia* and *AddressPresentation*, *CallParticipantsToBeForwarded* and *RecordCall*
- *AddCallParticipantRequest* operation is extended by the optional parameters, *AlertingMedia* and *AcceptCallRecording*.
- The new *RecordCallSession* and *RetrieveRecordedCallSessionMedia* operations are added.

5.1.3.1.1 Operation: MakeCallSession

MakeCallSessionRequest Input message of *MakeCallSession* operation is extended by NGSI interface, while all the definition of the *MakeCallSession* operation given in [3GPP 29.199-2] applies as basis.

In addition, an application can optionally specify *RingbackMedia* and *AlertingMedia* to indicate “waiting tones” and “alerting tones/videos/pictures” to be performed respectively. The waiting tone is to be used during the waiting period of the call establishment for a callee. The alerting media is to be used to notify the callee of arrival of a Call such as ringing tone. Example use cases of *RingbackMedia* are: adding of advertisement to a voice call to offer the call for a reduce price; picture application adds a frame/banner to the images used in the call.

In addition, an application can optionally specify *CallParticipantsToBeForwarded* to indicate a list of participants (“B-Party”) to be called in simultaneous or chained forwarding. If this parameter is set, the second URI provided in *CallParticipants* parameter is overwritten by this parameter. In the case of simultaneous forwarding, multiple participants indicated in *CallForward* structure will be called simultaneously. The first participant who has accepted the call will be connected and calls to other participants will be cancelled. In the case of chained forwarding, the first participant in *CallForward* structure is called first and if the first participant does not accept the call (e.g. Busy, No answer, Not reachable), the call to the first participant will be cancelled and the second participant in the structure will be called. This sequential forwarding will be applied to the next participant in the list until the participant accepts the call.

CallParticipantsToBeForward is used only if more than one participant is to be specified as B-party. That is *CallParticipantsToBeForwarded* should indicate more than or equal to 2 participants. In case that only one participant should be specified, the second entry of *CallParticipants* should be used, instead of *CallParticipantsToBeForward* parameter.

In addition, an application can specify *AddressPresentation* parameter to indicate if the participant name should be hidden. The first value of the *AddressPresentation* parameter corresponds to the first entry of *CallParticipants*, the second value of the *AddressPresentation* corresponds to the second entry of *CallParticipants*. When *CallParticipantsToBeForwarded* parameter is specified, the second value of the *AddressPresentation* will be applied to those participants indicated in the *CallParticipantsToBeForwarded*.

5.1.3.1.1.1. Input Message: MakeCallSessionRequest

MakeCallSessionRequest input message of the *MakeCallSession* operation as defined in [3GPP 29.199-2] is extended as follows, by introducing three additional parameters, *RingbackMedia* and *AlertingMedia* and *CallParticipantsToBeForwarded*.

Part name	Part type	Optional	Description	New parameters
CallParticipants	xsd:anyURI[1..2]	No	It contains the address of the first participant, and if supplied the second participant, involved in the call session.	
CallParticipantsToBeForwarded	common:CallForward	Yes	If this parameter is set, a second participant ("B-Party") indicated by a second URI in <i>CallParticipants</i> parameter is overwritten by this parameter and simultaneous or chained forwarding is performed to call the second participant.	NGSI-4:
CallingParticipantName	xsd:string	Yes	It contains the name of the caller, e.g. the name on whose behalf the call session is being established.	
Charging	common:ChargingInformation	Yes	Charge to apply to the call session	
MediaInfo	common:MediaInfo [0..unbounded]	Yes	It identifies one or more media type(s) for the call, i.e. the media type(s) to be applied to the participants in the call session. For each media type the media direction: incoming, outgoing, or bidirectional shall be indicated. An empty array shall have the same meaning as if the parameter is omitted. If the parameter <i>MediaInfo</i> is omitted, the media type(s) shall be negotiated by the underlying network.	
ChangeMediaNotAllowed	xsd: Boolean	No	If true, no call participant (user) in the call will be permitted to change media type during the call. If false the end user may change media type after the call is established as no network protection mechanism is set up to prevent participant (end user) initiated change of media type.	
RingbackMedia	xsd:anyURI[0..unbounded]	Yes	Media address delivered to the network. Media address is used by the network to deliver the Media to a caller to entertain during the waiting period of the call establishment with a callee. If n addresses are present, the next media will be delivered after the previous one has been delivered.	NGSI-4: Call Control extension
AlertingMedia	xsd:anyURI[0..2]	Yes	Media address for alerting tones/videos/pictures for the called participants. Media address is provided to A-party and B-party in <i>CallParticipants</i> parameter in the specified order respectively. When the <i>CallParticipantsToBeForwarded</i> is specified, all participants listed in <i>CallParticipantsToBeForwarded</i> will be alerted by the second	NGSI-4: Call Control extension

			media address from the AlertingMedia, if specified. The alerting tone is used for phones to ring.	
AddressPresentation	xsd:boolean[0..2]	Yes	If false, the address of the participant (e.g. telephone number) is not displayed to the other participant indicated in CallParticipants. Otherwise, it is displayed.	NGSI-4 extension to support anonymous call
RecordCall	xsd:boolean	Yes	If the parameter is true, the call will be recorded and the media will be retrievable, subject to policies. If the parameter is false or absent, the call will not be recorded.	NGSI-4 extension to support call recording

5.1.3.1.1.2. Output message : MakeCallSessionResponse

MakeCallSessionResponse output message of the MakeCallSession as defined in [3GPP 29.199-2] is applied unchanged as follows.

Part name	Part type	Optional	Description	New Parameter
CallSessionIdentifier	xsd:string	No	It identifies the specific call session created	

5.1.3.1.1.3. Referenced faults

Faults referenced by the MakeCallSession operation as defined in [3GPP 29.199-2] are applied with additional PolicyException, POL0003 – Too many addresses.

ServiceException from [3GPP TS 29.199-1]:

- SVC0001 - Service error.
- SVC0002 - Invalid input value.

PolicyException from [3GPP TS 29.199-1] and [NGSI-CCC]:

- POL0001 - Policy error.
- POL0002 – Privacy error
- POL0003 – Too many addresses
- POL0008 - Charging not supported.
- POL0011 – Media type not supported
- POL0012 – Too many description entries specified
- POL0013 – Addresses duplication.
- POL0270 – Call recording not supported – from [NGSI-CCC]

5.1.3.1.2 Operation: AddCallParticipant

AddCallParticipantRequest Input message of *AddCallParticipant* operation is extended by NGSI interface, while all the definition of the *AddCallParticipant* operation given in [3GPP 29.199-2] applies as basis.

In addition, an application can optionally specify *AlertingMedia* to indicate “alerting tones/videos/pictures” to be performed, in order to notify the callee of arrival of a Call such as ringing tone.

Note: The function “GetCallSessionRecordingStatus” can be invoked to inquire whether an ongoing session is recorded. This information can be used to inform the participant about the recording status prior to adding the participant to the session.

5.1.3.1.2.1. Input Message: AddCallParticipantRequest

AddCallParticipantRequest input message of the *AddCallParticipant* operation as defined in [3GPP 29.199-2] is extended as follows, by introducing an additional parameter, *AlertingMedia*.

Part name	Part type	Optional	Description	New Parameters
CallSessionIdentifier	xsd:string	No	It identifies the existing call session. This must be a non-null value as it identifies a pre-existing call session in the network	
CallParticipant	xsd:anyURI	No	It contains the address of the user to add to the existing call session identified by the CallSessionIdentifier	
MediaInfo	common:MediaInfo [0..unbounded]	Yes	It identifies one or more media type(s) for the participant to be added in the call session. For each media type the media direction: incoming, outgoing, or bidirectional shall be indicated. An empty array shall have the same meaning as if the parameter is omitted. If the parameter <i>MediaInfo</i> is omitted, the media type(s) shall be negotiated by the underlying network.	
AlertingMedia	xsd:anyURI	Yes	Media address for alerting tones/videos/pictures for the called participant.	NGSI-4: Call Control extension

5.1.3.1.2.2. Output message: AddCallParticipantResponse

AddCallParticipantResponse output message of the *AddCallParticipant* as defined in [3GPP 29.199-2] is applied unchanged as follows.

Part name	Part type	Optional	Description
None			

5.1.3.1.2.3. Referenced faults

Faults referenced by the *AddCallParticipant* operation as defined in [3GPP 29.199-2] is applied unchanged as follows.

ServiceException from [3GPP TS 29.199-1]:

- SVC0001 - Service error.

- SVC0002 - Invalid input value.
- SVC0261 - Call Session already terminated.

PolicyException from [3GPP TS 29.199-1]:

- POL0001 - Policy error.
- POL0011 – Media type not supported
- POL0240 – Too many participants. - from [3GPP TS 29.199-12]

5.1.3.1.3 Operation: GetCallSessionRecordingStatus

The *GetCallSessionRecordingStatus* operation is newly defined in NGSI. It allows retrieving the status of an ongoing recording.

5.1.3.1.3.1. Input Message: GetCallSessionRecordingStatusRequest

GetCallSessionRecordingStatusRequest input message of the *GetCallSessionRecordingStatus* operation is defined as follows:

Part name	Part type	Optional	Description	New Parameters
CallSessionIdentifier	xsd:string	No	It identifies the existing call session. This must be a non-null value.	NGSI-4

5.1.3.1.3.2. Output message: GetCallSessionRecordingStatusResponse

GetCallSessionRecordingStatusResponse output message of the *GetCallSessionRecordingStatus* operation is defined as follows:

Part name	Part type	Optional	Description	New Parameters
Status	common:Recording Status	No	The current status of the recording session.	NGSI-4

5.1.3.1.3.1. Referenced faults

ServiceException from [3GPP TS 29.199-1]:

- SVC0001 - Service error.
- SVC0002 - Invalid input value.
- SVC0261 - Call Session already terminated.

PolicyException from [3GPP TS 29.199-1]:

- POL0001 - Policy error

5.1.3.1.4 Operation: RecordCallSession

The *RecordCallSession* operation is newly defined in NGSI. It allows starting or stopping the recording of an ongoing session.

5.1.3.1.4.1. Input Message: RecordCallSession Request

RecordCallSessionRequest input message of the *RecordCallSession* operation is defined as follows:

Part name	Part type	Optional	Description	New Parameters
CallSessionIdentifier	xsd:string	No	It identifies the existing call session. This must be a non-null value.	NGSI-4
Operation	common:RecordingOperation	No	Value "StartRecording" starts the recording of a session, "StopRecording" stops the recording. Starting the recording might require the system to run an opt-in or opt-out process, as defined by legislations.	NGSI-4
ChargingInformation	common:ChargingInformation	Yes	Charging Information	NGSI-4

5.1.3.1.4.2. Output message: RecordCallSessionResponse

RecordCallSessionResponse output message of the *RecordCallSession* operation returns no parameters.

5.1.3.1.4.3. Referenced faults

ServiceException from [3GPP TS 29.199-1]:

- SVC0001 - Service error.
- SVC0002 - Invalid input value.
- SVC0261 - Call Session already terminated.

PolicyException from [3GPP TS 29.199-1] and [NGSI-CCC]:

- POL0001 - Policy error
- POL0002 – Privacy error.
- POL0270 – Call recording not supported – from [NGSI-CCC]

5.1.3.1.5 Operation: RetrieveRecordedCallSessionMedia

The *RetrieveRecordedCallSessionMedia* operation is newly defined in NGSI.

5.1.3.1.5.1. Input Message: RetrieveRecordedCallSessionMediaRequest

RetrieveRecordedCallSessionMediaRequest input message of the *RetrieveRecordedCallSessionMedia* operation is defined as follows:

Part name	Part type	Optional	Description	New Parameters
CallSessionIdentifier	xsd:string	No	It identifies the existing or past call session. This must be a non-null value.	NGSI-4
ChargingInformation	common:ChargingInformation	Yes	Charging Information	NGSI-4

5.1.3.1.5.2. Output Message: RetrieveRecordedCallSessionMediaResponse

RetrieveRecordedCallSessionMediaResponse output message of the *RetrieveRecordedCallSessionMedia* operation is defined as follows:

Part name	Part type	Optional	Description	New Parameters
CallParticipantInformation	CallParticipantInformation[0..unbounded]	Yes	Information about participants in the call	NGSI-4
RecordedMedia	common:RecordedMediaMetadata [0..unbounded]	Yes	Information about and reference to the media that was recorded.	NGSI-4

The recorded media can then be managed (e.g. retrieved, deleted) using [3GPP TS 29.199-21], by referencing them via the ContentIdentifier(s) that have been returned as part of the RecordedMediaMetadata structure.

5.1.3.1.5.3. Referenced faults

ServiceException from [3GPP TS 29.199-1]:

- SVC0001 - Service error.
- SVC0002 - Invalid input value.

PolicyException from [3GPP TS 29.199-1]:

- POL0001 - Policy error.

5.1.4 Fault definitions

5.1.4.1 PolicyException

5.1.4.1.1 POL0270: Call recording not supported

Name	Description	New Parameters
Message Id	POL0270	NGSI-4
Text	Recording not supported for this call session	NGSI-4
Variables	None	NGSI-4

5.1.5 Alternative approaches (informative)

5.1.5.1 RingbackMedia Functionality

While NGSI-4 interfaces provide a sophisticated way to specify the ring-back media functionality, alternative solution may be possible by the combination of [3GPP 29.199-2] and [3GPP 29.199-11] as described in Chapter 6.2 "Third party call with announcement between broker and customer".

6. NGSI-5: Technical Details

6.1 NGSI-5: Call Notification Extension Interface

6.1.1 Service Description

The NGSI-5 interface provides an extension to the service API related to call notification (event based call handling) whose basic scenario, interface descriptions and operations is described in [3GPP 29.199-3].

NGSI-5 extends by providing functionality to to configure the Media to be performed at specified condition during the call, recording the Media and configure the call handling method.

In addition, NGSI-5 interface uses the data type definition defined in Section □ of this document.

6.1.2 Sequence Diagrams

NGSI-5 Interface provides a scenario for the simultaneous and chained call forwarding in addition to the Sequence Diagrams given in [3GPP TS 29.199-3].

6.1.2.1 Simultaneous Call Forwarding

The figure below shows a scenario for the simultaneous call forwarding.

Outline of flow:

- An application configures call notification to receive *handleCalledNumber* requests when a user receives call attempts.
- A caller makes a call, the application receives *handleCalledNumber* request from Call Notification Web Service, and the application indicates simultaneous forwarding in the response to call callee 1, callee 2 and callee 3 by including the *ForwardingAddresses* element in the *Action* structure..
- If callee 3 accepts the call first, the call will be established between the caller and callee 3, and call attempts to callee 1 and callee 2 will be canceled.

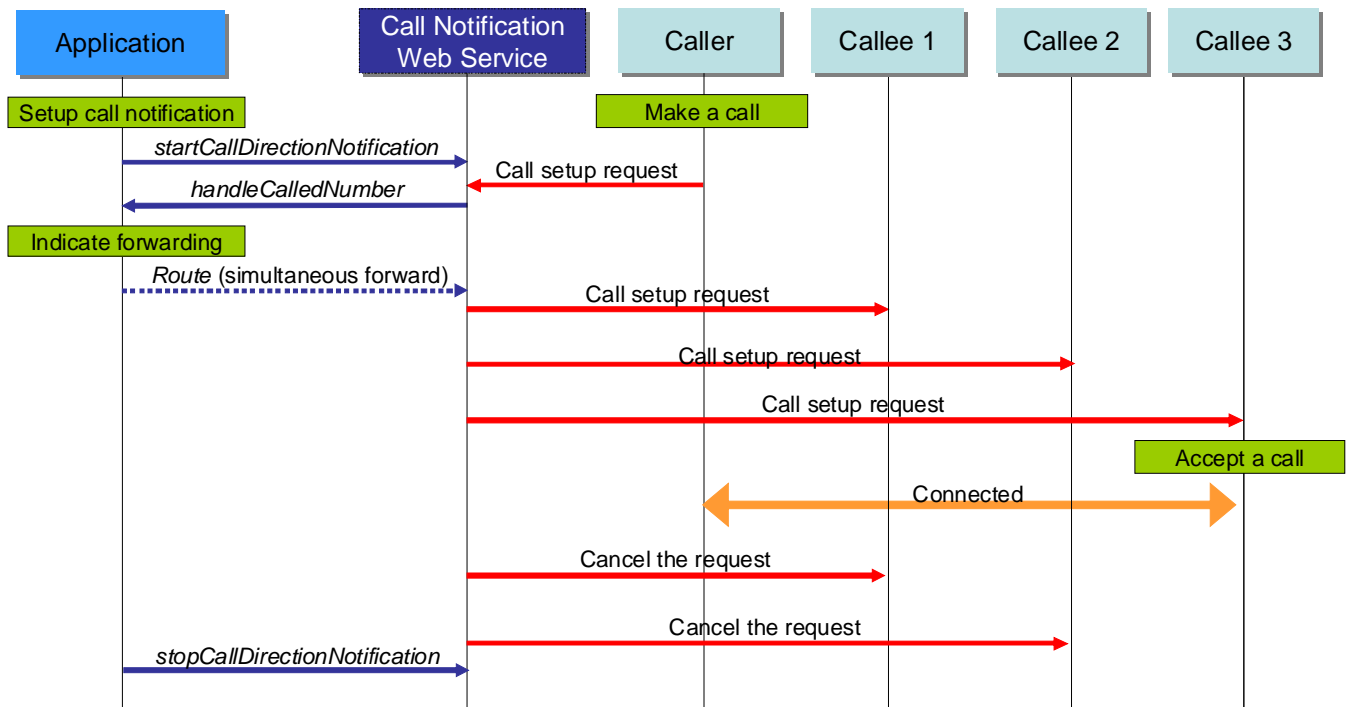

Figure 1: Example Sequence Diagram of Simultaneous Call Forwarding

6.1.2.2 Chained Call Forwarding

The figure below shows a scenario for the chained call forwarding.

Outline of flow:

- An application configures call notification to receive *handleCalledNumber* requests when a user receives call attempts.
- A caller makes a call, the application receives *handleCalledNumber* request from Call Notification Web Service, and the application indicates chained forwarding in the response to call callee 1, callee 2 and callee 3 (in forwarding order) by including the *ForwardingAddresses* element in the *Action* structure..
- If a line of callee 1 is busy, the call attempt to callee 1 will be canceled and next participant callee 2 will be called.
- If callee 2 does not answer the call, the call attempt will be canceled for timeout and next participant callee 3 will be called.
- If callee 3 accepts the call, the call will be established between the caller and callee 3.

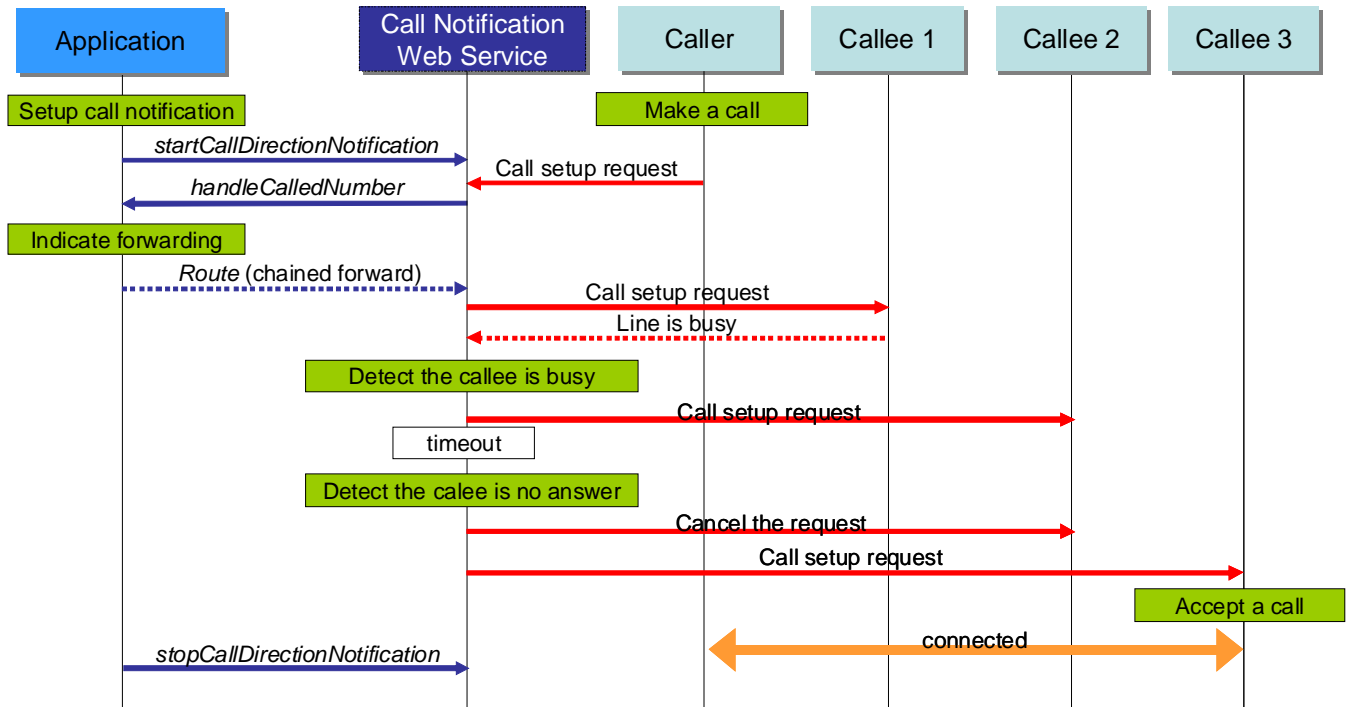

Figure 2: Example Sequence Diagram for Chained Call Forwarding

6.1.3 Data Type Definition

NGSI-5 interface uses the data type definition as defined in [3GPP 29.199-3] and [3GPP 29.199-1] with an extension to *Action* structure.

In addition, NGSI-5 interface uses the data type definition defined in Section □ of this document.

6.1.3.1 Action structure

The *Action* data type structure as defined in [3GPP 29.199-3] is extended as follows, by introducing new additional elements, *RingbackMedia*, *AlertingMedia*, *ForwardingAddresses*, *AddressPresentation* and *RecordCall*.

Element name	Element type	Optional	Description	New Parameters
ActionToPerform	ActionValues	No	Indicates the action to be performed.	
RoutingAddress	xsd:anyURI	Yes	The address to be used in case the action indicates 'Route'.	
ForwardingAddresses	common:CallForward	Yes	The address to be used in case the action indicates 'Route'. If multiple addresses are set in <i>CallForward</i> structure, <i>RoutingAddress</i> is omitted and simultaneous or chained forwarding is performed.	NGSI 5
Charging	common:ChargingInformation	Yes	Charge to apply to this call session	
MediaInfo	common:MediaInfo [0..unbounded]	Yes	The desired media type(s) in case the action indicates 'Route'. It identifies one or more media type(s) for the call, i.e. the media type(s) to be applied to the participants in the call session. For each media type the media direction: incoming, outgoing, or bidirectional shall be indicated. It includes the media direction: incoming, outgoing or bidirectional. Only to be used if the action indicates 'Route' An empty array shall have the same meaning as if the parameter is omitted. If the parameter <i>MediaInfo</i> is omitted, the media type(s) shall be negotiated by the underlying network.	
RingbackMedia	xsd:anyURI[0..unbounded]	Yes	Media address delivered to the network. Media address is used by the network to deliver the Media to caller to entertain during the waiting period of the call establishment with a callee. If n addresses are present, the next media will be delivered after the previous one has been delivered. The media is also known as CRBT (customized ring back tones). The delivery of the Media shall be stopped when the call is established. Media address may refer to SMIL description in order to support the sophisticated mode of media synchronization.	NGSI-5: Notification Extension
AlertingMedia	xsd:anyURI	Yes	Media address for alerting tones/videos/pictures for the called participant.	NGSI-5: Notification Extension

AddressPresentation	xsd:boolean	Yes	If false, the address of the caller (e.g. telephone number) is not displayed to the callee indicated in RoutingAddress or originally dialed. In other cases, it is displayed.	NGSI-5 extension to support anonymous call
RecordCall	xsd:boolean	Yes	This parameter is only evaluated in case the action indicates 'Route'. In this case, if the parameter is present and "true", the routed call will be recorded and the media will be retrievable. If the parameter is "false" or absent, the call will not be recorded.	NGSI-5 extension to support call recording

6.1.4 Interface definition

NGSI-5 interface are based on [3GPP 29.199-3] with the additional support of indication of ring-back tone as well as ring tone realized by introducing new data type as defined in Section 6.1.2 as its parameter.

All the Interfaces defined [3GPP 29.199-3] are extended without change of the operation itself, while all the definition of the operations given in [3GPP 29.199-3] applies as basis.

6.1.5 Alternative approaches (informative)

6.1.5.1 RingbackMedia Functionality

While NGSI-5 interfaces provide a sophisticated way to specify the ring-back media functionality, alternative way may be possible by the combination of [3GPP 29.199-3] and [3GPP 29.199-11] as follows:

- Step1. Invoke an operation HandleCalledNumber in Parlay X Part3.
- Step2. Invoke an operation PlayTextMessage or PlayAudioMessage in Parlay X Part11 with the return value of HandleCalledNumber (i.e. CallSessionIdentifier) to send multimedia resource that is described as RingbackMedia functionality to the caller.
- Step3. Invoke an operation NotifyAnswer in [3GPP 29.199-3]
- Step4. Invoke an operation EndMessage in [3GPP 29.199-11] with the return value of PlayTextMessage or PlayAudioMessage to stop the multimedia resource.

7. NGSI-6: Technical Details

7.1 NGSI-6: Call Handling Extension Interface

7.1.1 Service Description

The NGSI-6 interface provides an extension to the service API related to call handling whose basic scenario, interface descriptions and operations is described in [3GPP 29.199-10].

NGSI-6 extends [3GPP 29.199-10] by allowing the setting of additional rules to intelligently configure the call handling decisions such as simultaneous call, chained-forwarding as well as context awareness.

The configuration of the call handling may affect different types of Call, including SMS and MMS in addition to voice call, as defined in [OMA-DICT].

Note some of the description which implies the voice only call stated in [3GPP 29.199-10] should be read as any kind of call.

7.1.2 Data Type Definition

NGSI-6 interface uses the data type definition as defined in [3GPP 29.199-10], [3GPP 29.199-1] and [NGSI-Common] with following extensions:

- *PresenceRules* structure – newly added
- *ConditionForward* structure – extended
- *UnconditionalForward* structure – extended.
- *CommunicationServicePolicy* structure – extended.

In addition, NGSI-6 interface uses the data type definition defined in Section □ of this document.

7.1.2.1 PresenceRules structure

Information for handling of forwarding based on presence status of called party.

The *PresenceRules* structure is newly added by NGSI-6 interface.

Element name	Element type	Optional	Description	New parameters
PresenceData	common:PresenceData	No	Presence data	NGSI-6 Call Handling
OnPresenceStatusAddress	xsd:anyURI	No	If presence status of the called party matches to the presence status set to PresenceValue of this PresenceData structure, forward to this address. If presence status does not match or is not available, the forward will not be applied.	NGSI-6 Call Handling

7.1.2.2 ConditionalForward structure

Information on handling of forwarding for specific calling address.

The *ConditionalForward* structure in as defined in [3GPP 29.199-10] is extended as follows, by introducing new additional elements, *CallParticipantsToBeForwarded*, *OnNotReachableAddress* and *OnPresenceStatusRules*.

There are several parameters which specify the forwarding address on different conditions. Those parameters will be checked in the following order.

- CallParticipantsToBeForwarded.
- OnBusyAddress/OnNoAnswerAddress/OnNotReachableAddress/OnPresenceStatusRules/ForwardingAddress

Element name	Element type	Optional	Description	New/Modified parameters
CallingAddress	xsd:anyURI	No	Address that call is placed from	
ForwardingAddress	xsd:anyURI	No	Address to forward call to.	
CallParticipantsToBeForwarded	common:CallForward	Yes	Address to forward call to. If this parameter is set, <i>ForwardingAddress</i> , <i>onBusyAddress</i> , <i>onNoAnswerAddress</i> , <i>OnNotReachableAddress</i> and <i>OnPresenceStatusRules</i> parameters are overwritten by this parameter and simultaneous or chained forwarding is performed.	NGSI-6: call handling
OnBusyAddress	xsd:anyURI	No	If line is busy at forwarding address, forward to this address	
OnNoAnswerAddress	xsd:anyURI	No	If no answer at forwarding address, forward to this address	
OnNotReachableAddress	xsd:anyURI	Yes	If called party is not reachable, forward to this address	NGSI-6: call handling
OnPresenceStatusRules	PresenceRules[0..unbounded]	Yes	Call forwarding rules based on presence status of called party	NGSI-6: call handling

7.1.2.3 UnconditionalForward structure

Information for handling of forwarding unconditionally.

The *UnconditionalForward* structure in as defined in [3GPP 29.199-10] is extended as follows, by introducing new additional elements, *CallParticipantsToBeForwarded*, *OnNotReachableAddress* and *OnPresenceStatusRules*.

There are several parameters which specify the forwarding address on different conditions. Those parameters will be checked in the following order.

- CallParticipantsToBeForwarded.
- OnBusyAddress/OnNoAnswerAddress/OnNotReachableAddress/OnPresenceStatusRules/ForwardingAddress

Element name	Element type	Optional	Description	New parameters
ForwardingAddress	xsd:anyURI	No	Address to forward call to.	
CallParticipantsToBeForwarded	common:CallForward	Yes	Address to forward call to. If this parameter is set, <i>ForwardingAddress</i> , <i>onBusyAddress</i> , <i>onNoAnswerAddress</i> , <i>OnNotReachableAddress</i> and <i>OnPresenceStatusRules</i> parameters are overwritten by this parameter and simultaneous or chained forwarding is performed.	NGSI-6: call handling
OnBusyAddress	xsd:anyURI	No	If line is busy at forwarding address, forward to this address	
OnNoAnswerAddress	xsd:anyURI	No	If no answer at forwarding address, forward to this address	
OnNotReachableAddress	xsd:anyURI	Yes	If called party is not reachable, forward to this address	NGSI-6: call handling
OnPresenceStatusRules	PresenceRules[0..unbounded]	Yes	Call forwarding rules based on presence status of called party	NGSI-6: call handling

7.1.2.4 CommunicationServicePolicy structure

The CommunicationServicePolicy structure indicates Policy which should be applied when Communication Services are established / modified. The Policy should specify any necessary authorization and additional obligations for establishing/modifying Call (e.g. maximum number of calls, apply if in certain location).

Element name	Element type	Optional	Description	New parameters
Address	xsd:anyURI	No	Address of call participant to apply policy for. The address may be pseudonym or group [3GPP 29.199-13], URI.	NGSI-6
ParticipantAddresses	xsd:anyURI [0..unbounded]	Yes	Addresses of call participants corresponding the policy. The addresses may be pseudonyms or group [3GPP 29.199-13], URIs.	NGSI-6
Policy	xsd:any	No	Policy for communication service comprehending XML (for example: based on Common Policy [OMA-SUP-XSD] or [XACML] schema).	NGSI-6
PolicyID	xsd:string	No	An unique identifier to refer to It identifies a specific CommunicationServicePolicy.	NGSI-6

7.1.3 Interface definition

7.1.3.1 Interface: CallHandling

NGSI-6 interface specifies call enhancement functionalities to the *CallHandling* interface defined in [3GPP 29.199-10] as follows:

- *SetRules* operation is extended by referencing additional Exception, POL0003 – *Too many addresses* and POL0260: *Too many PresenceRules*

- *SetRulesForGroup* is extended by referencing additional Exception, POL0003 – *Too many addresses* and POL0260: *Too many PresenceRules*
- *SetCommunicationServicePolicy*, *GetCommunicationServicePolicies*, and *ClearCommunicationServicePolicies* are newly added operations.

NGSI-6 CallHandling Interface provides a mechanism for an application to specify how calls are to be handled for a specific address in addition to [3GPP 29.199-10]

- Preference setting – configuring preference for communication service.

7.1.3.1.1 Operation: SetRules

SetRules operation given in [3GPP 29.199-10] itself is unchanged but is extended by NGSI interface with its inclusion of additional Policy Exception.

7.1.3.1.1.1. Input message: SetRulesRequest

Part name	Part type	Optional	Description	New parameters
Addresses	xsd:anyURI [1..unbounded]	No	Addresses to handle calls for	
Rules	CallHandlingRules	No	Rules to apply for these addresses	

7.1.3.1.1.2. Output message: SetRulesResponse

Part name	Part type	Optional	Description	New parameters
Result	SetRulesResult [1..unbounded]	No	Result of setup for each of addresses provided	

7.1.3.1.1.3. Referenced faults

Faults referenced by the *SetRules* operation as defined in [3GPP 29.199-10] are applied with additional PolicyException, POL0003 – Too many addresses and POL0260: Too many PresenceRules.

ServiceException from [3GPP TS 29.199-1]

- SVC0001: Service error.
- SVC0002: Invalid input value.
- SVC0004: No valid addresses.
- SVC0006: Invalid group.

PolicyException from [3GPP TS 29.199-1] and Section 8 of this document

- POL0001: Policy error.
- POL0003 – Too many addresses
- POL0006: Groups not allowed.
- POL0007: Nested groups not allowed.
- POL0260: Too many PresenceRules

7.1.3.1.2 Operation: SetRulesForGroup

SetRules operation given in [3GPP 29.199-10] itself is unchanged but is extended by NGSI interface with its inclusion of additional Policy Exception.

7.1.3.1.2.1. Input message: SetRulesForGroupRequest

Part name	Part type	Optional	Description	New parameters
Addresses	xsd:anyURI [1..unbounded]	No	Addresses to handle calls for	
Rules	CallHandlingRules	No	Rules to apply for these addresses	

7.1.3.1.2.2. Output message: SetRulesForGroupResponse

Part name	Part type	Optional	Description	New parameters
Result	SetRulesResult [1..unbounded]	No	Result of setup for each of addresses provided	

7.1.3.1.2.3. Referenced faults

Faults referenced by the *SetGroupRules* operation as defined in [3GPP 29.199-10] are applied with additional PolicyException, POL0003 – Too many addresses and POL0260: Too many PresenceRules.

ServiceException from [3GPP TS 29.199-1]

- SVC0001: Service error.
- SVC0002: Invalid input value.
- SVC0004: No valid addresses.
- SVC0006: Invalid group.

PolicyException from [3GPP TS 29.199-1] and Section 7.1.4.1 of this document

- POL0001: Policy error.
- POL0003 – Too many addresses
- POL0006: Groups not allowed.
- POL0007: Nested groups not allowed.
- POL0260: Too many PresenceRules

7.1.3.1.3 Operation: SetCommunicationServicePolicy

The invocation of *setCommunicationServicePolicy* requests to set the Policy which is applied when a Call is established / modified of the entity specified by Address with other entities specified by ParticipantAddresses. The Policy should specify any necessary authorization and additional obligations for establishing/modifying Call (e.g. maximum number of calls, apply if in certain location).

The *Policy* can be set for the combination of *Address* and *ParticipantAddresses*. This operation may replace the existing Policy for the same combination of a given *Address* and *ParticipantAddresses* (including the case *ParticipantAddresses* is omitted), if exists.

7.1.3.1.3.1. Input message: SetCommunicationServicePolicyRequest

Element name	Element type	Optional	Description	New parameters
Address	xsd:anyURI	No	Address of call participant to apply policy for. The address may be pseudonym or group [3GPP 29.199-13], URI.	NGSI-6
ParticipantAddresses	xsd:anyURI [0..unbounded]	Yes	Addresses of call participants communicate with the participant specified by the Address. The addresses may be pseudonyms or group [3GPP 29.199-13], URIs. Omitting this element means the policy is not limited by the ParticipantAddresses.	NGSI-6
Policy	xsd:any	No	Policy for communication service comprehending XML (for example: based on Common Policy [OMA-SUP-XSD] or [XACML] schema).	NGSI-6

7.1.3.1.3.2. Output message: SetCommunicationServicePolicyRequest

Part name	Part type	Optional	Description	New parameters
PolicyID	xsd:string	Yes	It identifies a specific CommunicationServicePolicy.	NGSI-6

7.1.3.1.3.3. Referenced faults

ServiceException from [3GPP TS 29.199-1]:

- SVC0001: Service error.
- SVC0002: Invalid input value.

PolicyException from [3GPP TS 29.199-1] and Section 7.1.4 of this document:

- POL0001: Policy error.
- POL0261: Too many ParticipantAddresses.

7.1.3.1.4 Operation: GetCommunicationServicePolicyIds

The invocation of GetCommunicationServicePolicyIds requests to get the communication service policyID associated with the *Address*. If no Policies have been set for the *Address*, this operation returns a zero length array.

7.1.3.1.4.1. Input message: GetCommunicationServicePolicyIdsRequest

Part name	Part type	Optional	Description	New parameters
Address	xsd:anyURI	No	Address of call participant to apply policy for. The address may be pseudonym or group [3GPP 29.199-13], URI.	NGSI-6

7.1.3.1.4.2. Output message: GetCommunicationServicePoliciesIdsResponse

Part name	Part type	Optional	Description	New parameters
PolicyIDs	xsd:string [0..unbounded]	Yes	It identifies a specific CommunicationServicePolicies.	NGSI-6

7.1.3.1.4.3. Referenced faults

ServiceException from [3GPP TS 29.199-1]:

- SVC0001: Service error.
- SVC0002: Invalid input value.

PolicyException from [3GPP TS 29.199-1]:

- POL0001: Policy error.

7.1.3.1.5 Operation: GetCommunicationServicePoliciesByPolicyId

The invocation of GetCommunicationServicePolicyIds requests to get the Policy for the communication service specified by the PolicyID. The return value of The *PolicyIDs* can be obtained with SetCommunicationServicePolicy operation can be used.

7.1.3.1.5.1. Input message: GetCommunicationServicePoliciesByPolicyIdRequest

Part name	Part type	Optional	Description	New parameters
PolicyIDs	xsd:string [1..unbounded]	No	It identifies a specific CommunicationServicePolicy.	NGSI-6

7.1.3.1.5.2. Output message: GetCommunicationServicePoliciesByPolicyIdResponse

Part name	Part type	Optional	Description	New parameters
CommunicationServicePolicies	CommunicationServicePolicy [1..unbounded]	No	Policy for communication service set with SetCommunicationServicePolicies operation. The order of this array is the same as in the request array.	NGSI-6

7.1.3.1.5.3. Referenced faults

ServiceException from [3GPP TS 29.199-1]:

- SVC0001: Service error.
- SVC0002: Invalid input value.

PolicyException from [3GPP TS 29.199-1] and Section 7.1.4 of this document:

- POL0001: Policy error.
- POL0262 – Too many PolicyIDs

7.1.3.1.6 Operation: GetCommunicationServicePoliciesByAddress

The invocation of GetCommunicationServicePoliciesByAddress requests to get the Policy for communication service associated with the *Address*. If no Policies have been set for the *Address*, this operation returns a zero length array.

7.1.3.1.6.1. Input message: GetCommunicationServicePoliciesByAddressRequest

Part name	Part type	Optional	Description	New parameters
Address	xsd:anyURI	No	Address of call participant to apply policy for. The address may be pseudonym or group [3GPP 29.199-13], URI.	NGSI-6

7.1.3.1.6.2. Output message: GetCommunicationServicePoliciesByAddressResponse

Part name	Part type	Optional	Description	New parameters
CommunicationServicePolicies	CommunicationServicePolicy [0..unbounded]	Yes	A set of Policies for communication service associated with Address..	NGSI-6

7.1.3.1.6.3. Referenced faults

ServiceException from [3GPP TS 29.199-1]:

- SVC0001: Service error.
- SVC0002: Invalid input value.

PolicyException from [3GPP TS 29.199-1]:

- POL0001: Policy error.

7.1.3.1.7 Operation: ClearCommunicationServicePoliciesByPolicyId

The invocation of ClearCommunicationServicePoliciesByPolicyId requests to clear the Policies for communication service identified by the policyID specified. If no policies are found, this operation silently ignores the request, and does not return an error or fault message.

The *PolicyIDs* can be obtained with SetCommunicationServicePolicy operation.

7.1.3.1.7.1. Input message: ClearCommunicationServicePoliciesByPolicyIdRequest

Part name	Part type	Optional	Description	New parameters
PolicyIDs	xsd:string [1..unbounded]	No	Identifiers to clear communication service policies. If the Addresses is specified, this part should be ignored.	NGSI-6

7.1.3.1.7.2. Output message: ClearCommunicationServicePoliciesByPolicyIdResponse

Part name	Part type	Optional	Description	New parameters
None				

7.1.3.1.7.3. Referenced faults

ServiceException from [3GPP TS 29.199-1]:

- SVC0001: Service error.
- SVC0002: Invalid input value.

PolicyException from [3GPP TS 29.199-1] and Section 7.1.4 of this document:

- POL0001: Policy error.
- POL0262 – Too many PolicyIDs

7.1.3.1.8 Operation: ClearCommunicationServicePoliciesByAddress

The invocation of ClearCommunicationServicePoliciesByPolicyId requests to clear the Policies for communication associated with the specified Addresses. If no policies have been set for the given Identifier, this operation silently ignores the request, and does not return an error or fault message.

7.1.3.1.8.1. Input message: ClearCommunicationServicePoliciesByAddressRequest

Part name	Part type	Optional	Description	New parameters
Addresses	xsd:anyURI [1..unbounded]	No	Addresses to clear call handling for. The address may be pseudonym or group [3GPP 29.199-13], URI. If the PolicyID is specified, this part should be ignored.	NGSI-6

7.1.3.1.8.2. Output message: ClearCommunicationServicePoliciesByAddressResponse

Part name	Part type	Optional	Description	New parameters
None				

7.1.3.1.8.3. Referenced faults

ServiceException from [3GPP TS 29.199-1]:

- SVC0001: Service error.
- SVC0002: Invalid input value.

PolicyException from [3GPP TS 29.199-1] and Section 7.1.4 of this document:

- POL0001: Policy error.
- POL0003 – Too many addresses

7.1.4 Fault definitions

7.1.4.1 PolicyException

7.1.4.1.1 POL0260: Too many PresenceRules

Name	Description	New Parameters
Message Id	POL0 260	NGSI-6
Text	Too many PresenceRules is specified in message part %1	NGSI-6
Variables	%1 - message part	NGSI-6

7.1.4.1.2 POL0261: Too many ParticipantAddresses

Name	Description
Message Id	POL0261
Text	Too many ParticipantAddresses are specified in message part %1
Variables	%1 - message part

7.1.4.1.3 POL0262: Too many PolicyIDs

Name	Description
Message Id	POL0262
Text	Too many PolicyIDs are specified in message part %1
Variables	%1 - message part

8. NGSI-7: Technical Details

8.1 NGSI-7: Multimedia Conference Extension Interface

8.1.1 Service Description

The NGSI-7 interface provides an extension to the service API related to multimedia conferencing whose basic scenario, interface descriptions and operations is described in [3GPP 29.199-12].

NGSI-7 extensions support the interface for the configuration for participants to join the conference by dialling the conference address (i.e. telephone number) and enter the room number by push tone (i.e. DTMF), while [3GPP 29.199-12] only assumes the cases where participants to join the conferencing through the invitation from media resources (i.e. MRF). In other word, [3GPP 29.199-12] only supports the dial-out call to participants (participants are invited), while NGSI-7 provides the interfaces to configure the both cases of dial-out and dial-in call from participants.

Additionally, NGSI-7 interfaces allow the fine configuration of media being used for the conference.

8.1.2 Data Type Definition

NGSI-7 interface uses the data type definition as defined in [3GPP 29.199-12] and [3GPP 29.199-1] with following extensions:

- *ConferenceInfo* structure – extended
- *MediaMode* enumeration – newly added
- *Participant* structure – newly added.
- *ParticipantInfo* structure – extended
- *ParticipantMedia* structure – newly added.
- *ParticipantPrivileges* structure – newly added
- *ConferenceControlInfo* structure – newly added
- *SideConferenceOperation* enumeration – newly added
- *RecordConferenceOperation* enumeration – newly added
- *RecordedConferenceMediaMetadata* structure – newly added
- *RecordingStatus* enumeration – newly added

8.1.2.1 ConferencInfo structure

The *ConferenceInfo* structure as defined in [3GPP 29.199-12] is extended as follows, by introducing new optional elements, marked by “NGSI-7” in the last column.

Name	Type	Optional	Description	New parameters
Status	ConferenceStatus	No	Status of the conference	
StartTime	xsd:dateTime	No	The time at which the conference was created	
ActiveTime	xsd:dateTime	No	The time at which the conference was activated	
Duration	xsd:int	No	The duration of the conference so far (in seconds)	
Owner	xsd:anyURI	No	Conference owner	
NumberOfParticipants	xsd:int	No	Current number of connected participants	
MaximumNumberOfParticipants	xsd:int	No	Maximum number of participants	
CallSessionIdentifier	xsd:string	No	CallSessionIdentifier for the conference	
ConferenceDescription	xsd:string	No	Conference description	
ConferenceAddress	xsd:anyURI	Yes	Conference address (e.g. SIP-URI, TEL-URI) that is used when participants join the conference by dialling.	NGSI-7
ConferenceRoomIdentifier	xsd:string	Yes	Conference room identifier (e.g. Numbers in 5 letters length such as 12345) that is used when participants join the conference room hosted in the address of ConferenceAddress.	NGSI-7
Chair	Participant	Yes	Conference chair	NGSI-7
IsLocked	xsd:Boolean	Yes	Indicates whether conference is locked (true) or not locked (false). Default: false	NGSI-7

8.1.2.2 MediaMode enumeration

The *MediaMode* enumeration is newly added by NGSI-7 interface.

Enumeration value	Description	New parameters
ParticipantBased	Media resources are applied based on participants.	NGSI-7
RoleBased	Media resources are applied based on roles of participants.	NGSI-7
AllParticipants	Media resources are applied for all participants.	NGSI-7

8.1.2.3 Participant structure

The *Participant* structure is newly added by NGSI-7 interface.

Name	Type	Optional	Description	New parameters
Participant	xsd:anyURI	No	Participant identifier	NGSI-7
Role	xsd:string	Yes	Participant role (e.g. chair, scribe, etc). If not present, no specific role is assigned to the participant. In this case, the participant will not match any role and thus RoleBased media selection will not be applied.	NGSI-7

8.1.2.4 ParticipantInfo structure

The *ParticipantInfo* structure as defined in [3GPP 29.199-12] is extended as follows, by introducing new optional elements, marked by “NGSI-7” in the last column.

Name	Type	Optional	Description	New parameters
Participant	xsd:anyURI	No	Participant identifier	
MediaInfo	common:MediaInfo[1..unbounded]	No	Media information currently used	
StartTime	xsd:dateTime	No	Time this participant joined the conference	
Status	ParticipantStatus	No	Status of participant	
Privileges	ParticipantPrivileges	Yes	Rights of participant. If this element is missing the participant has no specific privileges.	NGSI-7

8.1.2.5 ParticipantMedia structure

The *ParticipantMedia* structure is newly added by NGSI-7 interface.

Name	Type	Optional	Description	New parameters
Mode	MediaMode	No	Media selection mode	NGSI-7
Participant	xsd:anyURI	Yes	Participant identifier. It is used when MediaMode is ParticipantBased.	NGSI-7
Role	xsd:string	Yes	Participant role (e.g. chair, scribe, etc). It is used when MediaMode is RoleBased.	NGSI-7
Media	xsd:anyURI	Yes	Media address (e.g. SIP-URI, TEL-URI, URL)	NGSI-7

8.1.2.6 ParticipantPrivileges structure

The *ParticipantPrivileges* structure is newly defined in NGSI. It models the privileges of a conference participant.

Name	Type	Optional	Description	New parameters
IsChair	xsd:boolean	Yes	Participant is chair. Default: false.	NGSI-7
IsWhiteboardAllowed	xsd:boolean	Yes	Participant has the whiteboard operation right. Default: false.	NGSI-7
IsApplicationShareAllowed	xsd:boolean	Yes	Participant has the application share operation right. Default: false.	NGSI-7
IsWebURIAAllowed	xsd:boolean	Yes	Participant have the web slides operation right. Default: false.	NGSI-7
IsFiletransferAllowed	xsd:boolean	Yes	Participant has the file transfer operation right. Default: false.	NGSI-7
IsVoteAllowed	xsd:boolean	Yes	Participant has the vote operation right. Default: false.	NGSI-7

8.1.2.7 ConferenceControlInfo Structure

The *ConferenceControlInfo* structure is newly added by NGSI-7 interface.

Name	Type	Optional	Description	New parameters
MuteParticipant	Participant[0..unbounded]	Yes	Mute the participants' voice. SHALL NOT be present if MuteAllParticipants is present.	NGSI-7
UnmuteParticipant	Participant[0..unbounded]	Yes	Unmute the participants' voice. SHALL NOT be present if MuteAllParticipants is present.	NGSI-7
MuteAllParticipants	xsd:boolean	Yes	Mute (true) or Unmute (false) all participants' voice. SHALL NOT be present if MuteParticipant or UnmuteParticipant is present.	NGSI-7
ChangeChair	Participant	Yes	Move chair privilege to specified participant.	NGSI-7
LockConference	xsd:boolean	Yes	Lock the conference (true) or unlock the conference (false)	NGSI-7
AllowWhiteboardOperation	Participant	Yes	Grant the whiteboard operation right to the participant in the data conference.	NGSI-7
AllowApplicationShareOperation	Participant	Yes	Grant the application share operation right to the participant in the data conference.	NGSI-7
AllowWebURIOperation	Participant[0..unbounded]	Yes	Grant the web URI share operation right to the participants in the data conference.	NGSI-7
AllowFiletransferOperation	Participant	Yes	Grant the file transfer operation right to the participant in the data conference.	NGSI-7
AllowVoteOperation	Participant[0..unbounded]	Yes	Grant the vote operation right to the participants in the data conference.	NGSI-7

8.1.2.8 SideConferenceOperation enumeration

Enumeration value	Description	New parameters
Create	Create the side conference	NGSI-7
Retrieve	Get the side conference state information	NGSI-7
Update	Update the side conference	NGSI-7
Delete	Delete the side conference	NGSI-7

8.1.3 Interface definition

8.1.3.1 Interface: MultimediaConference

NGSI-7 interface specifies enhanced functionalities to the *MultimediaConference* interface defined in [3GPP 29.199-12] by introducing *SetupConference* operation.

8.1.3.1.1 Operation: SetupConference

The invocation of *SetupConference* requests to set the configuration of the multi-media conference call identified by *callSessionIdentifier*.

The optional parameter *Password* specifies the password which needs to be provided by participants to join this multi-media conference call.

An application can specify media that may be used to notify the conference participants of the events that one of the participants has joined or left the conference using the optional parameter *OnJoinMedia* and *OnLeaveMedia* with the combination of *Participants* parameter which specifies the identifier of the participant, to whom the media is assigned. There are three scenarios supported as follows. In all cases, *ParticipantMedia* must be specified for *OnJoinMedia* and/or *OnLeaveMedia*

1. In order to set the media guidance based on the participant identifier, *MediaMode* of *ParticipantMedia* must be set to *ParticipantBased* and the parameter *Participant* and *Media* of *ParticipantMedia* must be also set.
2. In order to set the media guidance based on participant role, *MediaMode* of *ParticipantMedia* must be set to *RoleBased* and the parameter pair of *Participant* and *Role* of *Participant* structure must be also set. This allows the example that participants can hear media guidance such as “The chair has joined the conference room”, when a chair of the conference is joined.
3. In order to set the same media guidance for the joining/leaving event of all the participants, *MediaMode* of *ParticipantMedia* must be set to *AllParticipants* In this case, *Participant* and *Role* parameters of *ParticipantMedia* structure can be omitted.

The optional parameter *onWaitMedia* specifies the media to be performed when participants are waiting for the start of the conference call after their joining to the conference.

POL0240 is raised in case of too many *participant* parameters are set in *Participants*, *OnJoinMedia* and *OnLeaveMedia*.

8.1.3.1.1.1. Input message: SetupConferenceRequest

Part name	Part type	Optional	Description	New parameters
CallSessionIdentifier	xsd:string	No	Call session identifier; the Conference identifier	NGSI-7: Multimedia Conference extension
Password	xsd:string	Yes	Password which is used when a participant joins the multi-media conference call	NGSI-7: Multimedia Conference extension
Participants	Participant[0..unbounded]	Yes	Pairs of participants and their roles (e.g. chair, scribe, etc) in the multi-media conference call	NGSI-7: Multimedia Conference extension
OnJoinMedia	ParticipantMedia[0..unbounded]	Yes	Media address (e.g. SIP-URI, TEL-URI, URL) which is used when a participant joins the multi-media conference call	NGSI-7: Multimedia Conference extension
OnLeaveMedia	ParticipantMedia[0..unbounded]	Yes	Media address (e.g. SIP-URI, TEL-URI, URL) which is used when a participant leaves the multi-media conference call	NGSI-7: Multimedia Conference extension
OnWaitMedia	xsd:anyURI	Yes	Media address (e.g. SIP-URI, TEL-URI, URL) which is used when a participant joined a conference call and is waiting for the start of the multi-media conference call	NGSI-7: Multimedia Conference extension
RecordConference	xsd:boolean	Yes	If the parameter is true, the conference will be recorded and the media will be retrievable, subject to policies. If the parameter is false or absent, the conference will not be recorded.	NGSI-7: Multimedia Conference extension

8.1.3.1.1.2. Output message: SetupConferenceResponse

Part name	Part type	Optional	Description	New Parameter
None				

8.1.3.1.1.3. Referenced faults

ServiceException from [3GPP TS 29.199-1]:

- SVC0001 - Service error.
- SVC0002 - Invalid input value.

PolicyException from [3GPP TS 29.199-1] and [NGSI-CCC]:

- POL0001 - Policy error.
- POL0002 - Privacy error.
- POL0240 -- Too many participants
- POL0243 – Conference recording not supported (from [NGSI-CCC])

8.1.3.1.2 Operation: RecordConference

The *RecordConference* operation is newly defined in NGSI. The invocation of *RecordConference* requests to operate a recording of a conference during the multi-media conference call identified by *CallSessionIdentifier*.

An application can schedule conference recording by start/stop operation at a particular time. For multiple start/stop operations in one conference, system needs to store multiple recorded conference media.

8.1.3.1.2.1. Input message: RecordConferenceRequest

Part name	Part type	Optional	Description	New parameters
CallSessionIdentifier	xsd:string	No	Call session identifier; the Conference identifier	NGSI-7: Multimedia Conference extension
Operation	common:RecordingOperation	No	Value "StartRecording" starts the recording of the conference, "StopRecording" stops the recording. Starting the recording might require the system to run an opt-in or opt-out process, as defined by legislations.	NGSI-7: Multimedia Conference extension
ChargingInformation	common:ChargingInformation	Yes	Charging Information	NGSI-7: Multimedia Conference extension

8.1.3.1.2.2. Output message: RecordConferenceResponse

RecordConferenceResponse output message of the *RecordConference* operation returns no parameters.

8.1.3.1.2.3. Referenced faults

ServiceException from [3GPP TS 29.199-1]:

- SVC0001 - Service error.

- SVC0002 - Invalid input value.
- SVC0212 - Conference already terminated.

PolicyException from [3GPP TS 29.199-1] and [NGSI-CCC]:

- POL0001 - Policy error.
- POL0002 – Privacy error
- POL0240 – Too many participants. - from [3GPP TS 29.199-12]
- POL0243 – Conference recording not supported – from [NGSI-CCC]

8.1.3.1.3 Operation: GetConferenceRecordingStatus

The *GetConferenceRecordingStatus* operation is newly defined in NGSI. It allows retrieving the status of an ongoing recording.

8.1.3.1.3.1. Input message: GetConferenceRecordingStatusRequest

GetConferenceRecordingStatusRequest input message of the *GetConferenceRecordingStatus* operation is defined as follows:

Part name	Part type	Optional	Description	New Parameters
CallSessionIdentifier	xsd:string	No	It identifies the existing conference. This must be a non-null value.	NGSI-7

8.1.3.1.3.2. Output message: GetConferenceRecordingStatusResponse

GetConferenceRecordingStatusResponse output message of the *GetConferenceRecordingStatus* operation is defined as follows:

Part name	Part type	Optional	Description	New Parameters
Status	common:Recording Status	No	The current status of the recording session.	NGSI-7

8.1.3.1.3.3. Referenced faults

ServiceException from [3GPP TS 29.199-1]:

- SVC0001 - Service error.
- SVC0002 - Invalid input value.
- SVC0212 - Conference already terminated.

PolicyException from [3GPP TS 29.199-1] and [NGSI-CCC]:

- POL0001 - Policy error.

8.1.3.1.4 Operation: RetrieveRecordedConferenceMedia

The *RetrieveRecordedConferenceMedia* operation is newly defined in NGSI.

8.1.3.1.4.1. Input message: RetrieveRecordedConferenceMediaRequest

RetrieveRecordedConferenceMediaRequest input message of the *RetrieveRecordedConferenceMedia* operation is defined as follows:

Part name	Part type	Optional	Description	New Parameters
CallSessionIdentifier	xsd:string	No	It identifies the existing or past conference. This must be a non-null value.	NGSI-7
ChargingInformation	common:ChargingInformation	Yes	Charging Information	NGSI-7

8.1.3.1.4.2. Output message: RetrieveRecordedConferenceMediaResponse

RetrieveRecordedConferenceMediaResponse output message of the *RetrieveRecordedConferenceMedia* operation is defined as follows:

Part name	Part type	Optional	Description	New Parameters
CallParticipantInformation	CallParticipantInformation[0..unbounded]	Yes	Information about participants in the conference	NGSI-7
RecordedMedia	common:RecordedMediaMetadata[0..unbounded]	Yes	Information about and reference to the media that was recorded.	NGSI-7

The recorded media can then be managed (e.g. retrieved, deleted) using [3GPP TS 29.199-21], by referencing them via the ContentIdentifier(s) that have been returned as part of the RecordedMediaMetadata structure.

8.1.3.1.4.3. Referenced faults

ServiceException from [3GPP TS 29.199-1]:

- SVC0001 - Service error.
- SVC0002 - Invalid input value.

PolicyException from [3GPP TS 29.199-1]:

- POL0001 - Policy error.

8.1.3.1.5 Operation: ConferenceControl

The invocation of *ConferenceControl* requests to set conference control information of the multi-media conference call identified by *callSessionIdentifier*.

An application can specify the conference control information using the parameter *ConferenceControlInformation*. The detail conference control information includes major chair control operation parameters such as muteParticipant, unmuteParticipant, MuteAllParticipants, ChangeChair, LockConference, Allowwhiteboardoperation, Allowapplicationshareoperation, AllowwebURIoperation, Allowfiletransferoperation, Allowvoteoperation etc.

8.1.3.1.5.1. Input message: ConferenceControlRequest

Part name	Part type	Optional	Description	New parameters
CallSessionIdentifier	xsd:string	No	Call session identifier; the Conference identifier	NGSI-7: Multimedia Conference extension
ConferenceControlInformation	ConferenceControlInfo	No	Set conference control information of the multi-media conference	NGSI-7: Multimedia Conference extension

8.1.3.1.5.2. Output message: ConferenceControlResponse

ConferenceControlResponse output message of the *ConferenceControl* operation returns no parameters.

8.1.3.1.5.3. Referenced faults

ServiceException from [3GPP TS 29.199-1]:

- SVC0001 - Service error.
- SVC0002 - Invalid input value.

PolicyException from [3GPP TS 29.199-1] and [NGSI-CCC]:

- POL0001 - Policy error.

8.1.3.1.6 Operation: SideConference

An application can use *SideConference* requests to realize advanced conference function such as internal sidebar, external sidebar, observing and coaching. For detail conference system operation, refer to sections 6.3.8 and 6.3.10 of [draft-ietf-xcon-cmp-06]. For detail scenarios and examples, refer to section 8 of [draft-ietf-xcon-examples-03].

In internal sidebar all the participants are also participants of the main conference.

In external sidebar some participants are not part of the main conference.

Observing and coaching functions are applicable to call centres or remote training sessions where there is a supervisor (i.e. observer, coach) who can monitor the conference. A participant in these side conferences may be a supervised participant or a customer.

In observing scenario, the supervisor listens to or sees the session but can not be heard or seen by other participants (i.e. observed participants). In coaching scenario, the supervisor listens to or sees the session but can only be heard or seen by the supervised participant (i.e. coached participants).

The invocation of *SideConference* requests to operate side/child conference of the multi-media conference call identified by *callSessionIdentifier*, the result of side/child conference is returned by *SideConference* response based on the multimedia conference service.

An application can specify the operation for side/child conference using the parameter *SideConferenceOperation*, the operation can be create, retrieve, update or delete.

An application can specify the side conference information using the parameter *SideConferenceInformation*, which is comprehending XML of side conference information, refer to IETF SIP Conferencing data model element <conference-info>, <sidebars-by-ref> and <sidebars-by-val> in [RFC 4575].

An application can invoke observing and coaching by updating the side conference information which include participants (observer, observed participants or coach, coached participants) and related media. For detail refer to section 8.4 of [draft-ietf-xcon-examples-03].

8.1.3.1.6.1. Input message: SideConferenceRequest

Part name	Part type	Optional	Description	New parameters
CallSessionIdentifier	xsd:string	No	Call session identifier; the Conference identifier	NGSI-7: Multimedia Conference extension
SideConferenceOperation	SideConferenceOperation	No	the operation for side/child conference, such as create, inquiry, update or delete	NGSI-7: Multimedia Conference extension
SideConferenceInformation	[RFC 4575]:sidebars-by-val-type	No	Side Conference Information. Refer to [RFC 4575] xmlns:tns="urn:ietf:params:xml:ns:conference-info" element <conference-info>, <sidebars-by-ref> and <sidebars-by-val>	NGSI-7: Multimedia Conference extension

8.1.3.1.6.2. Output message: SideConferenceResponse

Part name	Part type	Optional	Description	New parameters
Result	[RFC 4575] : sidebars-by-val-type	No	Side Conference Information. Refer to [RFC 4575] xmlns:tns="urn:ietf:params:xml:ns:conference-info" element <conference-info>, <sidebars-by-ref> and <sidebars-by-val>	NGSI-7: Multimedia Conference extension

8.1.3.1.6.3. Referenced faults

ServiceException from [3GPP TS 29.199-1]:

- SVC0001 - Service error.
- SVC0002 - Invalid input value.

PolicyException from [3GPP TS 29.199-1] and [NGSI-CCC]:

- POL0001 - Policy error.

8.1.4 Fault definitions

8.1.4.1 ServiceException

8.1.4.1.1 SVC0212: Conference already terminated

Name	Description	New Parameters
Message Id	SVC0212	NGSI-7
Text	Conference has already been terminated	NGSI-7
Variables	none	NGSI-7

8.1.4.2 PolicyException

8.1.4.2.1 POL0243: Conference recording not supported

Name	Description	New Parameters
Message Id	POL0243	NGSI-7
Text	Recording not supported for this conference	NGSI-7
Variables	none	NGSI-7

Appendix A. Change History

(Informative)

A.1 Approved Version History

Reference	Date	Description
OMA-TS-NGSI_Call_Control_and_Configuration-V1_0-20120529-A	29 May 2012	Status changed to Approved by TP Ref TP Doc # OMA-TP-2012-0203-INP_NGSI_V1_0_ERP_for_final_Approval

Appendix B. Static Conformance Requirements (Normative)

As NGSI v1.0 specifies the level of abstract interfaces, no testing of those is applicable. Therefore, the Static Conformance Requirements (SCR) tables are not defined. Those are subject for definitions in the related technical specification defining the bindings.

The notation used in this appendix is specified in [SCRRULES].

B.1 SCR for NGSI Call Control and Configuration Client

None.

B.2 SCR for NGSI Call Control and Configuration Server

None.