



Instant Messaging using SIMPLE Architecture

Candidate Version 1.0 – 16 Aug 2007

Open Mobile Alliance
OMA-AD-SIMPLE_IM-V1_0-20070816-C

Use of this document is subject to all of the terms and conditions of the Use Agreement located at <http://www.openmobilealliance.org/UseAgreement.html>.

Unless this document is clearly designated as an approved specification, this document is a work in process, is not an approved Open Mobile Alliance™ specification, and is subject to revision or removal without notice.

You may use this document or any part of the document for internal or educational purposes only, provided you do not modify, edit or take out of context the information in this document in any manner. Information contained in this document may be used, at your sole risk, for any purposes. You may not use this document in any other manner without the prior written permission of the Open Mobile Alliance. The Open Mobile Alliance authorizes you to copy this document, provided that you retain all copyright and other proprietary notices contained in the original materials on any copies of the materials and that you comply strictly with these terms. This copyright permission does not constitute an endorsement of the products or services. The Open Mobile Alliance assumes no responsibility for errors or omissions in this document.

Each Open Mobile Alliance member has agreed to use reasonable endeavors to inform the Open Mobile Alliance in a timely manner of Essential IPR as it becomes aware that the Essential IPR is related to the prepared or published specification. However, the members do not have an obligation to conduct IPR searches. The declared Essential IPR is publicly available to members and non-members of the Open Mobile Alliance and may be found on the “OMA IPR Declarations” list at <http://www.openmobilealliance.org/ipr.html>. The Open Mobile Alliance has not conducted an independent IPR review of this document and the information contained herein, and makes no representations or warranties regarding third party IPR, including without limitation patents, copyrights or trade secret rights. This document may contain inventions for which you must obtain licenses from third parties before making, using or selling the inventions. Defined terms above are set forth in the schedule to the Open Mobile Alliance Application Form.

NO REPRESENTATIONS OR WARRANTIES (WHETHER EXPRESS OR IMPLIED) ARE MADE BY THE OPEN MOBILE ALLIANCE OR ANY OPEN MOBILE ALLIANCE MEMBER OR ITS AFFILIATES REGARDING ANY OF THE IPR'S REPRESENTED ON THE “OMA IPR DECLARATIONS” LIST, INCLUDING, BUT NOT LIMITED TO THE ACCURACY, COMPLETENESS, VALIDITY OR RELEVANCE OF THE INFORMATION OR WHETHER OR NOT SUCH RIGHTS ARE ESSENTIAL OR NON-ESSENTIAL.

THE OPEN MOBILE ALLIANCE IS NOT LIABLE FOR AND HEREBY DISCLAIMS ANY DIRECT, INDIRECT, PUNITIVE, SPECIAL, INCIDENTAL, CONSEQUENTIAL, OR EXEMPLARY DAMAGES ARISING OUT OF OR IN CONNECTION WITH THE USE OF DOCUMENTS AND THE INFORMATION CONTAINED IN THE DOCUMENTS.

© 2007 Open Mobile Alliance Ltd. All Rights Reserved.

Used with the permission of the Open Mobile Alliance Ltd. under the terms set forth above.

Contents

1.	SCOPE (INFORMATIVE)	6
2.	REFERENCES	7
2.1	NORMATIVE REFERENCES	7
2.2	INFORMATIVE REFERENCES	8
3.	TERMINOLOGY AND CONVENTIONS	9
3.1	CONVENTIONS	9
3.2	DEFINITIONS	9
3.3	ABBREVIATIONS	11
4.	INTRODUCTION (INFORMATIVE)	13
4.1	TARGET AUDIENCE	13
4.2	PLANNED PHASES	13
5.	ARCHITECTURAL MODEL	14
5.1	DEPENDENCIES	14
5.2	ARCHITECTURAL DIAGRAM	15
5.3	IM FUNCTIONAL ENTITIES	15
5.3.1	IM Client	15
5.3.2	IM Server	16
5.3.2.1	IM Server Behaviour	17
5.3.2.1.1	Participating and Controlling IM Function	17
5.3.2.1.2	Presence Functionality	19
5.3.2.1.3	Deferred Messaging Function	20
5.3.2.1.4	Conversation History Function	21
5.3.2.1.5	Nested Lists and Nested Groups	23
5.3.2.2	OMA IM Conference Model	23
5.3.2.3	IM Media Stream Path	24
5.3.2.3.1	Entities in the User Plane of IM Sessions	24
5.3.2.3.2	Entities in the User Plane of Deferred IM	25
5.3.2.3.3	Entities in the User Plane of Conversation History Function	25
5.3.2.3.4	Entities in the User plane of Deferred/Conversation History IM delivery	26
5.3.2.4	IM Server Roles	27
5.3.2.4.1	Participating IM Function	27
5.3.2.4.2	Controlling IM Function	27
5.3.2.4.3	Deferred Messaging IM Function	28
5.3.2.4.4	IM Conversation History Function	28
5.3.3	IM XML Document Management Server (XDMS)	28
5.4	EXTERNAL ENTITIES PROVIDING SERVICES TO IM	29
5.4.1	SIP/IP Core	29
5.4.2	XML Document Management Entities	29
5.4.2.1	Shared List XDMS	29
5.4.2.2	Shared Group XDMS	30
5.4.2.3	Shared Profile XDMS	30
5.4.2.4	Shared Policy XDMS	30
5.4.2.5	Aggregation Proxy	30
5.4.2.6	Search Proxy	30
5.4.2.7	XDM Client (XDMS)	30
5.4.3	Presence Entities	30
5.4.3.1	Presence Server (PS)	30
5.4.3.2	Presence Client Source	30
5.4.3.3	Presence Client Watcher	30
5.4.4	Charging Enabler	31
5.4.5	Device Management Server	31
5.5	REFERENCE POINTS	31
5.5.1	Reference Point IM-1: IM-Client ↔ SIP/IP-Core	31
5.5.2	Reference Point IM-2: IM-Server ↔ SIP/IP-Core	31
5.5.3	Reference Point IM-3: IM-Server ↔ IM XDMS	32

- 5.5.4 Reference Point IM-4: IM-Server ↔ Shared List XDMS 32
- 5.5.5 Reference Point IM-5: IM XDMS ↔ SIP/IP Core 32
- 5.5.6 Reference Point IM-6: IM XDMS ↔ Aggregation Proxy 32
- 5.5.7 Reference Point IM-7: IM-Client ↔ IM-Server 33
- 5.5.8 Reference Point IM-8: IM-Server ↔ IM-Server 33
- 5.5.9 Reference Point IM-9: IM-Client ↔ Remote IM-Client 33
- 5.5.10 Reference Point IM-10: IM Server ↔ Shared Group XDMS 33
- 5.5.11 Reference Point IM-11: IM Server ↔ Shared Profile XDMS 34
- 5.5.12 Reference Point IM-12: IM XDMS ↔ Search Proxy 34
- 5.5.13 Reference Point IM-13: IM Server ↔ Shared Policy XDMS 34
- 5.5.14 Reference Point IP-1: SIP/IP Core ↔ SIP/IP Core 34
- 5.5.15 Reference point CH-x: IM Server - Charging Enabler 34
- 5.5.16 Reference Point XDM-1: XDM Client – SIP/IP Core 34
- 5.5.17 Reference Point XDM-2: Shared XDMSs – SIP/IP-Core 34
- 5.5.18 Reference Point XDM-3: XDM Client- Aggregation Proxy 34
- 5.5.19 Reference Point XDM-4: Aggregation Proxy – Shared XDMSs 35
- 5.5.20 Reference Point XDM-5: XDM Client – Aggregation Proxy 35
- 5.5.21 Reference Point XDM-6: Aggregation Proxy – Search Proxy 35
- 5.5.22 Reference Point XDM-7: Search Proxy – Shared XDMSs 35
- 5.5.23 Reference Point PRS-5: Presence Server – Shared List XDM Server 35
- 5.5.24 Reference Point PRS-6: Presence XDM Server – SIP/IP Core 35
- 5.5.25 Reference Point PRS-7: Aggregation Proxy – Presence XDM Server 35
- 5.5.26 Reference Point PRS-8: Presence Server - Presence XDM Server 35
- 5.5.27 Reference Point PRS-1: Presence Source – SIP/IP Core 35
- 5.5.28 Reference Point PRS-2: Presence Watcher – SIP/IP Core network 35
- 5.5.29 Reference Point PRS-3: SIP/IP Core – Presence Server 35
- 5.5.30 Reference Point DM-1: DM Client – DM Server 35
- 6. SYSTEM CONCEPTS 36**
- 6.1 SECURITY 36**
- 6.1.1 General 36
- 6.1.2 Trust Model 36
- 6.1.3 SIP signalling security 36
 - 6.1.3.1 Integrity and confidentiality protection 36
 - 6.1.3.2 Assurance of user identity 36
 - 6.1.3.3 SIP MESSAGE Security 36
- 6.1.4 User Plane security 37
- 6.1.5 Relation between SIP Signalling and User Plane Security 37
 - 6.1.5.1 Denial of Services 37
- 6.1.6 XDMS Security 37
- 6.2 AUTHORIZATION 37**
- 6.3 PRIVACY 37**
- 6.3.1 XDMS Security and Privacy 38
- 6.4 LAWFUL INTERCEPT 38**
- 6.4.1 Reference point LI-1: Functional Entities – Law Enforcement Monitoring Facility 38
- APPENDIX A. CHANGE HISTORY (INFORMATIVE) 39**
- A.1 APPROVED VERSION HISTORY 39**
- A.2 DRAFT/CANDIDATE VERSION 1.0 HISTORY 39**

Figures

- Figure 1: SIMPLE Instant Messaging Functional Architecture 15
- Figure 2: User A creates Ad hoc chat session and invites User B to the chat session 17
- Figure 3: Chat server hosted by Network 3 18
- Figure 4: Message distribution by either group mechanism or Uri-list service 19

Figure 5: User B is not available for IM and IM Server B activates Deferred Messaging role to store the message.....	20
Figure 6: A group distribution from User A when User B2 is Unavailable (Deferred Messaging)	21
Figure 7: User B has requested the IM Server B to store the conversation.....	22
Figure 8: Both User A and User B2 have requested to store the conversation.....	22
Figure 9: General relationship between Participation IM function, Controlling IM function and IM Clients.....	23
Figure 10: IM media stream path options for IM sessions.....	24
Figure 11: IM media stream path options for Deferred IM.....	25
Figure 12: IM media stream path options for storing Conversation History.....	26
Figure 13: IM media stream path options of Deferred/Conversation History IM delivery	26

1. Scope

(Informative)

The scope of this SIP/SIMPLE Instant Messaging Architecture Document (AD) is to define the architecture for the IM service enabler based on the IETF SIP/SIMPLE specifications.

This document fulfils the requirements for functional capabilities of the SIMPLE IM enabler and proposes a functional architecture to support this service enabler as described in the Instant Messaging Requirements document [IM-RD]. Within the context of the OMA Service Environment (OSE), this document defines all functional entities within and external to the SIMPLE IM enabler and all their reference points.

2. References

2.1 Normative References

- [3GPP TS 23.002] 3GPP TS 23.002, "Network architecture", URL: <http://www.3gpp.org/>
- [3GPP TS 23.228] 3GPP TS 23.228, "IP Multimedia Subsystem (IMS); Stage 2", URL: <http://www.3gpp.org/>
- [3GPP TS 24.229] 3GPP TS 24.229, "IP Multimedia Call Control Protocol based on Session Initiation Protocol (SIP) and Session Description Protocol (SDP); Stage 3", URL: <http://www.3gpp.org/>
- [3GPP TS 33.107] 3GPP TS 33.107, "Technical Specification Group Services and System Aspects, 3G security; Lawful interception architecture and functions", URL: <http://www.3gpp.org/>
- [3GPP TS 33.203] 3GPP TS 33.203, "Access security for IP-based services", URL: <http://www.3gpp.org/>
- [3GPP TS 33.210] 3GPP TS 33.210, "Network Domain Security", URL: <http://www.3gpp.org/>
- [3GPP2 S.R0086-0] 3GPP2 S.R0086-0, URL: <http://www.3gpp2.org/>
- [3GPP2 X.P0013.0] 3GPP2 X.P0013.0, URL: <http://www.3gpp2.org/>
- [3GPP2-X.P0013.2] 3GPP2-X.P0013.2, IP Multimedia Subsystem (IMS); Stage-2, URL: <http://www.3gpp2.org/>
- [3GPP2 X.S0013.4] 3GPP2 X.P0013.4 IP Multimedia Call Control Protocol based on SIP & SDP; Stage-3, URL: <http://www.3gpp2.org/>
- [ARC-INVENT] "Inventory of Architectures and Services", Version 1.0, Open Mobile Alliance™, OMA-Inventory-of-Architectures-and-Services-V1_0, URL: <http://www.openmobilealliance.org/>
- [IM-RD] "Instant Messaging Requirements", Version 1.0, Open Mobile Alliance™, OMA-RD-IM-V1_0, URL: <http://www.openmobilealliance.org/>
- [MSRP] "The Message Session Relay Protocol", B. Campbell, May 2004, URL: <http://www.ietf.org/internet-drafts/draft-ietf-simple-message-sessions-12.txt>
- [OMA DM] "OMA Device Management Protocol", Version 1.1.2, Open Mobile Alliance™, OMA-DM-V1_2, URL: <http://www.openmobilealliance.org/>
- [OMA DM Bootstrap] "OMA Device Management, Bootstrap document" Version 1.2, Open Mobile Alliance™, URL: <http://www.openmobilealliance.com/>
- [OMA IMS] "Utilization of IMS capabilities, Architecture", Version 1.0, Open Mobile Alliance™, OMA-AD-IMS-V1_0, URL: <http://www.openmobilealliance.org/>
- [OMA OSE] "OMA Service Environment", Version 1.0, Open Mobile Alliance™, OMA-Service-Environment-V1_0, URL: <http://www.openmobilealliance.org/>
- [PRES] "OMA Presence Simple", Version 1.0, Open Mobile Alliance™, OMA-ERP-Presence_SIMPLE-V1_0, URL: <http://www.openmobilealliance.org/>
- [PRES-AD] "Presence SIMPLE Architecture Document", Version 1.0, Open Mobile Alliance™, OMA-AD-Presence_SIMPLE-V1_0, URL: <http://www.openmobilealliance.org/>
- [PRES-RD] "Presence SIMPLE Requirements", Version 1.0, Open Mobile Alliance™, OMA-RD-Presence_SIMPLE-V1_0, URL: <http://www.openmobilealliance.org/>
- [RFC2119] "Key words for use in RFCs to Indicate Requirement Levels", S. Bradner, March 1997, URL: <http://www.ietf.org/rfc/rfc2119.txt>
- [RFC2778] "A Model for Presence and Instant Messaging", M. Day et al, February 2000, URL: <http://www.ietf.org/rfc/rfc2778.txt>
- [RFC3261] "SIP: Session Initiation Protocol", J. Rosenberg et al, June 2002,

- URL: <http://www.ietf.org/rfc/rfc3261.txt>
- [RFC3265] "Session Initiation Protocol (SIP)-Specific Event Notification", A. B. Roach, June 2002, URL: <http://www.ietf.org/rfc/rfc3265.txt>
- [RFC3428] "Session Initiation Protocol (SIP) Extension for Instant Messaging", December 2002, URL: <http://www.ietf.org/rfc/rfc3428.txt>
- [XDM-AD] "XML Document Management Architecture", Version 2.0, Open Mobile Alliance™, OMA-AD-XDM-V2_0, URL: <http://www.openmobilealliance.org/>
- [XDM-ERP] "OMA XML Document Management", Version 2.0, Open Mobile Alliance™, OMA-ERP-XDM-V2_0, URL: <http://www.openmobilealliance.org/>

2.2 Informative References

- [3GPP TR 29.847] 3GPP TR 29.847, "Conferencing based on SIP, SDP and other protocols"; URL: <http://www.3gpp.org/>
- [RFC 4353] "A Framework for Conferencing with the Session Initiation Protocol (SIP)" URL: <http://www.ietf.org/rfc/rfc4353.txt>
- [EXPLODER] "Multiple-Recipient MESSAGE Requests in the Session Initiation Protocol (SIP)", September 2006. URL: <http://www.ietf.org/internet-drafts/draft-ietf-sip-uri-list-message-00.txt>
- [OMA-Charging] "Charging Architecture", Version 1.0, Open Mobile Alliance™, OMA-AD-Charging-V1_0, URL: <http://www.openmobilealliance.org/>
- [OMA-DICT] "OMA Dictionary", Version 2.1, Open Mobile Alliance™, OMA-Dictionary-V2_1, URL: <http://www.openmobilealliance.org/>
- [OMA PoC AD] "Push to talk over Cellular (PoC) – Architecture", Version 1.0, Open Mobile Alliance™, OMA-AD-PoC-V1_0, URL: <http://www.openmobilealliance.org>

3. Terminology and Conventions

3.1 Conventions

The key words “MUST”, “MUST NOT”, “REQUIRED”, “SHALL”, “SHALL NOT”, “SHOULD”, “SHOULD NOT”, “RECOMMENDED”, “MAY”, and “OPTIONAL” in this document are to be interpreted as described in [RFC2119].

All sections and appendixes, except “Scope” and “Introduction”, are normative, unless they are explicitly indicated to be informative.

3.2 Definitions

Ad hoc Chat	An IM session for multiple users that does not involve the use of predefined groups. The list of users for the Ad hoc Chat is created on-the-fly and disappears after the Ad hoc Chat session ends. Note that Pager mode and Large Message mode communication do not constitute an Ad hoc Chat.
Access Control	User specified rules that restrict the set of other users that may establish IM conversations to the user.
Conference	A multi-party conversation with a central point of control. Defined in [RFC4353]
Conference focus	A central element in the ‘Controlling IM Function’ that maintains direct relationship with each participant by means of a SIP dialog. Each dialog can belong to a different SIP session i.e. Maintains the SIP dialogue in the IM conference session.
Contact List	A Contact List is a URI-list available to the IM User that contains the addresses of IM Users which utilize the shared user lists stored in Shared List XDMS [XDM-AD]. Also referred to as ‘buddy list’.
Controlling IM Function	Controlling IM Function provides centralized IM session handling which includes MSRP Media distribution between conference participants, participants information, and executes conference control policies i.e acts as a IM conference server.
Conversation	An ordered exchange of instantmessages between users.
Conversation History	A record of a user’s IM communication during all modes of operation (Pager, Large message, and Session modes). The Conversation History includes both the messages exchanged as well as supplementary descriptive information (e.g., topics and time of communication).
Conversation History IM Function	Conversation History IM Function provides the capabilities to manage storage, retrieval and manipulation (e.g., delete, rename) of conversation histories including obtaining descriptive information about conversations.
Deferred Message	If an intended recipient of an IM Pager mode or Large Message mode communication is not available, either due to the recipient’s Inbox settings or the recipient being IM offline, the message is stored in the IM server for later delivery. I.e. the IM becomes deferred message.
Deferred Message IM Function	Deferred Message IM Function provides the capabilities to manage storage of deferred messages as well as push delivery and retrieval of deferred messages when user becomes available for IM communication.
IM Client	An IM Client is a functional entity that resides on the IM user equipment and is used to access the IM service.
IM Conference	An exchange of near real-time messages between more than two users with a central point of control. The IM conference uses an instantiation of an IM session, uniquely identified by a URI to enable message exchange An IM conference is usually hosted by a network entity which creates, maintains and manipulates the conferencing features.
IM Group	An IM group is a list of addresses such as URIs. Each group is identified by a unique address.
IM Session	An association that is established at some moment in time, continues for a finite duration and then is dissolved. The session is established between two or more users and facilitates the exchange of near real-time messages.
IM Server	A network entity that provides near real-time messaging.
IM Service	The instant message offering presented by a service provider that utilizes the IM Enabler and potentially

	other enablers.
Instant Message (IM)	A message delivered to a user in near real time. IMs are often exchanged back-and-forth between users in a conversational fashion.
Interface	See [OMA-DICT].
Internet Connected Device	A device connected to the Internet, using an IM specific portal which allows the support of IM Services when an ordinary IM Client is not available. An IM specific portal is a web page that offers IM functionality site that offers IM functionality.
IP Multimedia Subsystem (IMS)	The 3GPP/3GPP2 IP Multimedia Subsystem (IMS) offering service capabilities such as SIP registration and rendezvous, presence information, and messaging. The IMS has been recognized by the OMA as a major source of relevant resources for the OSE.
Large Message mode	This mode is used to send a single large instant message using MSRP. Since MSRP is used, a SIP session must be established, but it is torn down after the single message is transmitted.
Many-to-Many	Also called a Conference in SIMPLE IM.
MSRP Switch	A media level entity that receives MSRP messages and delivers them to the other conference participants [MSRP-CHAT].
Multimedia Encapsulation	Also called MIME. A formatting technique for rich messages originally used for email, but now used for HTTP and many other things. MIME allows serializing one or more message elements into a simple text stream. The message elements may be text, pictures, and many other types of data, or external references using a URI to an element actually stored elsewhere such as a web page.
Nested Group	A nested group is when an IM group contains a URI that points to another IM group URI.
Nested List	Nested List: When a <list> element(s) in a <resource list> document contain other <list> elements.
Notification	A message, delivered in response to a subscription, which delivers information about an associated event in the format defined by the relevant event package. Defined in [RFC3265].
One-to-Many	One user sends messages to a group of users using Pager or Large Message mode. Typically, the user sends messages to a uri-list or group name.
One-to-One	One user communicates with a single user. It includes Peer-to-Peer, pager mode and Ad hoc chat with only two participants.
Pager mode	Sending a single instant message using the SIP MESSAGE method as defined in [RFC 3248] without establishing an IM session.
Participating IM Function	The Participating IM Function provides IM Session handling and policy enforcement for incoming and outgoing IM Sessions (i.e.offers IM access and service policies), and may provide the media convey function between IM Client and the Controlling IM Function.
Peer-to-Peer	It is a specific case of One-to-One session where one IM Client communicates with another IM Client by establishing a direct MSRP media path between them.
Presence	Information about the status and reachability of a specific individual, usually a person.
Presence Information	Dynamic set of information pertaining to a Presentity that may include presence elements such as the status, reachability, willingness, and capabilities of that Presentity. Note: This definition is compatible with the 3GPP/3GPP2 definitions, as well as the IETF definition, though the latter is quite generic. Source: [PRES-RD]
Presence Server (PS)	A logical entity that receives <i>Presence Information</i> from a multitude of <i>Presence Sources</i> pertaining to the <i>Presentities</i> it serves and makes this information available to Watchers according to the rules associated with those Presentities. Note: In IETF SIMPLE Presence a Presence Server is referred to as a Presence Agent. Source: [PRES-RD]
Presence Source	A logical entity that provides Presence Information pertaining to exactly one or more Presentities to the Presence Server. 3GPP/3GPP2 Presence User Agents, Presence Network Agents, and Presence External Agents are examples of Presence Sources. Note: In IETF SIMPLE Presence, Presence Sources are referred to as Presence User Agents. In IETF 2778,

they are referred to as Presentities.

Source: [PRES-RD]

Presentity

A logical entity that has *Presence Information* associated with it. This Presence Information may be composed from a multitude of *Presence Sources*. A Presentity is most commonly a reference for a person, although it may represent a role such as “help desk” or a resource such as “conference room #27”. Presentities are generally referenced by distinguished names, such as “dean.willis@softarmor.com” or by phone numbers like “+19724735455”. In SIMPLE, Presentities are generally referenced using a sip:, pres: or tel: URL.

Note: This definition maps better to the RFC2778 definition of a Principal, rather than that of RFC2778 Presentity. This definition is compatible with the 3GPP/3GPP2 definitions of presentity, as well as that of IETF SIMPLE Presence.

Source: [PRES-RD]

Proxy

A SIP node that forwards messages according to the proxy rules defined in [RFC3261]. SIP requests made by nodes using SIMPLE are processed by proxies just like any other SIP request would be.

Reference Point

See [OMA-DICT].

Registrar

A SIP server node that receives and responds to SIP REGISTER messages. A registrar is generally associated with an administrative domain and may be associated with a presence server. The purpose of the registrar is to store the association of a "contact with presentity". This association may also be called a "binding". Defined in [RFC3261].

Remote Network

Network comprising of the SIP/IP core and the IM server of the remote IM Client.

Session

A stateful association of presence and other user preference, capability and identity data through which it is possible to communicate immediate messages. A session may be established between IM users or between an IM user and an IM Server.

Session mode

Sending and receiving instant messages in an IM session.

Session Initiation Protocol (SIP)

An IETF “Session Initiation Protocol”, intended for the development of session-based applications. [RFC3261]

SIMPLE

A methodology and set of extensions to SIP supporting the Instant Messaging requirements defined by IETF.

Subscription

A persistent relation between a subscriber and an event source (often a presence server for a presentity) by which the subscriber requests notifications of a specific even for a set duration. Defined in [RFC3265].

System

An organized assembly of subsystems and components designed to perform a (a set of) specific function(s).

System Message

A special type of message sent by the IM Server for different purposes (e.g. advice of charge, service notifications, advertisements, instructions, etc). System Messages MAY contain a list of possible options and require actions or response from the user.

Uri-list service

SIP application service or functionality that receives a MESSAGE request with a URI-list and sends a similar MESSAGE request to each URI in the list [EXPLODER].

User

A human using the described features through a terminal device. In this document the terms “User” and “IM user” are equivalent.

User Profile

A set of data elements containing User specific information such as an identifier of the user, communication addresses etc.

Watcher

A node that requests presence information for a particular presentity. This request may be a singular fetch operation, in which case the watcher is called a "fetcher". If the fetch operation is repeated periodically, the watcher is called a "poller". If the watcher subscribes to receive notification of changes in the presence of presentity, the watcher is called a "subscriber". In order to avoid confusion with the term "subscriber" as used in mobile phone networks, 3GPP has chosen to call this role a "subscribed watcher". Defined in [RFC2778].

3.3 Abbreviations

3GPP 3rd Generation Partnership Project

3GPP2 3rd Generation Partnership Project 2

AD	Architecture Document
AP	Aggregation Proxy
CR	Change Request
HTTP	Hyper Text Transfer Protocol
IETF	Internet Engineering Task Force
IM	Instant Messaging
IMS	IP Multimedia Subsystem
IP	Internet Protocol
ISC	IMS Service Control interface
MIME	Multipurpose Internet Mail Extension
MSRP	Message Session Relay Protocol
OMA	Open Mobile Alliance
OSE	OMA Service Environment
PS	Presence Server
RFC	Request for Comments
RD	Requirement Document
SIMPLE	SIP Instant Message and Presence Leveraging Extensions
SIP	Session Initiation Protocol
TS	Technical Specification
URI	Uniform Resource Identifier
URL	Universal Resource Locator
XCAP	Extensible mark-up language (XML) Configuration Access Protocol
XDM	XML Document Management
XDMC	XDM Client
XDMS	XDM Server
XML	Extensible Mark-up Language

4. Introduction (Informative)

Instant Messaging (IM) is a set of system capabilities that provides both a framework for future service development and an application allowing near real-time exchange of Instant Messaging messages between users, whether using mobile networks or fixed Internet connections. This document defines the architecture for the OMA Instant Messaging service using the IETF SIP [RFC3261] protocol with SIMPLE extensions. Instant Messaging is described in terms of actions taken by Instant Messaging Client, Instant Messaging Server and various other network elements.

Within the context of the OMA Service Environment (OSE), the IM architecture relies on common OMA enablers such as Presence, XDM and Device Management Services to provide the overall functionality of the SIMPLE IM Enabler. This architecture allows server hosted and client hosted IM conversations. It also supports conferences and One-to-One modes of the IM service.

The reference points between the IM enabler and various other network elements are coded according to [ARC-INVENT] and are prefixed with a common “IM” prefix.

4.1 Target Audience

The target audience for this document includes but is not limited to the following:

- The Working Group(s) that will create specifications based on this subject matter
- Architecture Working Group
- Interoperability Working Group
- Security Working Group
- Mobile Commerce and Charging Working Group
- Presence and Availability Group
- Device Management Group

4.2 Planned Phases

This enabler meets all requirements listed under Release “IM 1.0” in [IM-RD]. The list of deferred requirements for this enabler are marked as “future” in the RD.

5. Architectural Model

5.1 Dependencies

The OMA IM Enabler is generally dependent on the OMA Service Environment (OSE) as specified by [OMA-OSE] for interactions with other OMA enablers and in particular the IM Enabler is dependent on OMA Presence and XDM Enablers for presence and group management capabilities, respectively. Although the IM Service can operate without Presence functionality, this OMA enabler is needed to realize all of the requirements in the Instant Messaging RD [IM-RD]. Because of this tight relationship, this document explicitly shows architectural components from both the OMA Presence and XDM enablers along with IM components created in this document. Generally, in the IM Architecture:

- Interfaces to retrieve presence information specific to IM are provided by the OMA Presence Service [PRES-AD].
- Interfaces to create, delete, or modify IM groups are provided by the OMA XDM Service [XDM-AD]. In addition, the OMA XDM Service provides the foundation to create, delete and modify IM specific policy in the IM XDM.
- Further, the IM Service is dependent on an underlying SIP infrastructure to transport SIP messages between IM entities. The architecture in this document refers to this infrastructure as the SIP/IP Core. A particular instantiation of the SIP/IP Core is an IP Multimedia Subsystem as specified in either 3GPP [3GPP-IMS] or 3GPP2 [3GPP2-IMS].

Finally, the IM Service is dependent on some specifications developed in the Internet Engineering Task Force (IETF).

- The base protocol for session based IM is based on [MSRP].

5.2 Architectural Diagram

Figure 1 shows all functions that both directly and indirectly contribute to the realization of the SIMPLE IM service. It includes all reference points to the external as well internal functional entities interacting with the SIMPLE IM server.

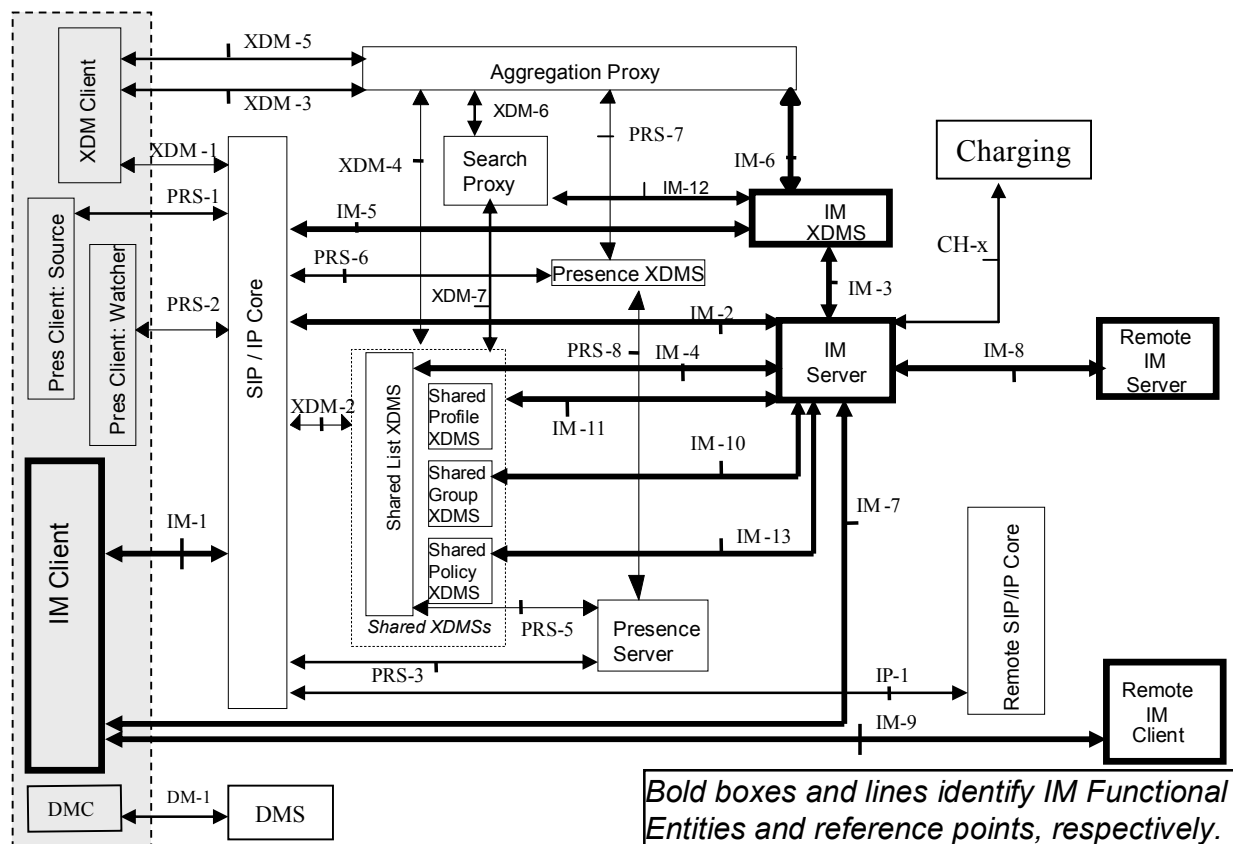

Figure 1: SIMPLE Instant Messaging Functional Architecture

NOTE: XDM-2, XDM-4 and XDM-7 reference points show connection to the logically combined "shared XDMs" entity since the same reference point is used for all the shared XDMs inside the combined entity, see [XDM-AD]. However, the procedures on the interfaces between the Shared XDM entities and IM enabler are different, hence these interfaces are shown by IM-4, IM-10, IM-11, IM-12 and IM-13.

5.3 IM Functional Entities

5.3.1 IM Client

The IM Client is used to access the IM service and, for example, may reside on a mobile/fixed terminal or a portal in conjunction with an Internet Connected Device.

The IM Client SHALL:

- Perform registration with the SIP/IP Core.
- This enabler requires the IM Client be authenticated to the SIP/IP Core. It is not a matter of SIP/IP Core policy.
- Allow IM session initiation, participation, and termination.

- Send and receive instant messages using URI or a Display-Name to/from peer IM Clients, or the IM Server.
- Incorporate IM configuration data downloaded by the provisioning system (e.g., over-the-air activation).
- Notify the user of an incoming message or invitation to an IM session.
- Publish IM Client service settings (e.g., incoming IM barring activation) to the IM Server.

The IM Client MAY:

- Interact with Presence Client to handle presence information (e.g. publish presence information and subscribe to presence information).
- Issue commands (based on user requests) to instruct IM Server to start/stop IM conversation recording.

In the case of an Internet Connected Device, the portal performs the functions of an IM client on behalf of the user (e.g., communication and authentication to the SIP/IP Core). The combination of Internet Connected Device and portal appears to IM Server as an IM Client. This allows the support of IM Services when a stand alone IM Client is not available.

5.3.2 IM Server

The IM Server SHALL:

- Manage (send and receive) IM from users in One-to-One and many-to-many modes using either URI or a Display-Name.
- Support IM Clients using both mobile and fixed networks.
- Interoperate with remote IM Server i.e. interoperate with IM Server residing in other networks using reference points IM-2 and IM-8.
- In the case of session mode messaging , act as conference focus and maintain public and private chat rooms .
- In the case of session mode messaging , act as an MSRP switch including the replication of messages within chat rooms [MSRP].
- Provide online delivery of message.
- Store messages for offline users.
- Handle functionality for deferred message delivery for offline users and later retrieval.
- Use Shared XDMSs for IM related policies and rules (such as block lists).
- Support receiving and maintaining IM Client provided service settings (e.g., incoming IM barring activation).
- Be able to send System Messages.
- Use information stored at Shared XDMSs as input for IM Service user lists shared with other application execution.

The IM Server SHOULD be able to:

- Store the IM conversation upon user's request.
- Provide IM Conversation history management and retrieval functionality.
- Limit the storage size for IM conversations allocated to the IM user.
- Notify the users about the size of stored IM conversation.

- Notify the sender about the allowed maximum IM message size.
- Use presence to allow efficient delivery according to the recipient availability.

The IM Server MAY be able to:

- Inform IM Client on message delivery.
- Update Presence information.

5.3.2.1 IM Server Behaviour

The list of functions in the IM Server can be logically categorized into IM service specific functionalities, Generic functionalities, Deferred Messaging functionalities and History Conversation functionalities. The IM Service specific set of functions are listed in section 5.3.2.4.1, under Participating IM Function, the generic set of functions offering group communications or conferencing services for the IM are listed in section 5.3.2.4.2 under Controlling IM Function, the set of functionalities offering deferred messaging services are listed in section 5.3.2.4.3 under Deferred Messaging IM Function and the set of Conversation History functionalities are listed in section 5.3.2.4.4 under Conversation History Function.

The Participating IM Function acts as an IM service point for users, offering IM access and service policies. The Controlling IM Function acts as a conference server providing centralized session handling, media distribution (in IM case only MSRP), participants information, and executes conference control policies. The Deferred Messaging IM Function acts as an alternate IM service when an intended/targeted user for IM is not available for IM pager-mode communication.

5.3.2.1.1 Participating and Controlling IM Function

The Participating IM Function and the Controlling IM Function MAY be either collocated in a single network entity or interoperate using OMA standardized interface i.e., interfaces IM-2 and IM-8 of the IM architecture as depicted in Figure 1.

An IM server assumes the role of Participation IM Function or Controlling IM Function depending on which set of functions it is executing in a particular active IM session. This means that an IM server MAY perform the role of either Participating IM Function or Controlling IM Function or both.

An IM Server assumes these roles during session set up and the role lasts for the duration of the IM session. For example, in case of Ad hoc chat session or One-to-One IM session, the IM server of the inviting user assumes the Controlling IM Function role as shown in Figure 2.

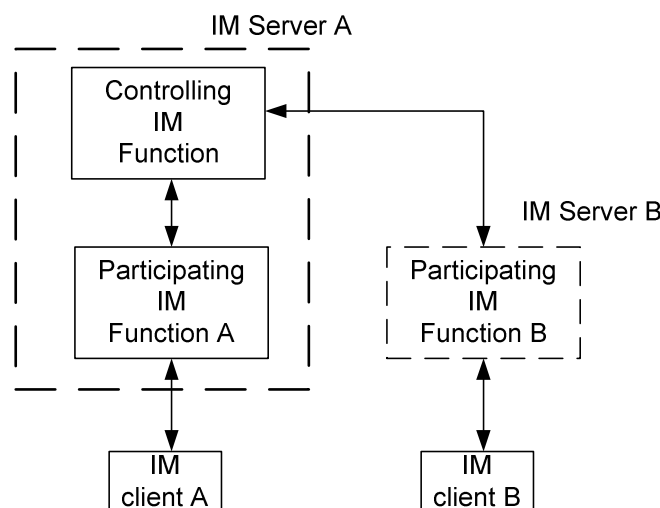

Figure 2: User A creates Ad hoc chat session and invites User B to the chat session

One-to-One IM sessions can be considered as Ad hoc conferences with only two participants. This makes it easier for One-to-One IM sessions to be extended to One-to-many Ad hoc conferencing. Controlling IM Function can be optional in One-to-One IM sessions since the need for a centralised control point would not be necessary. Peer-to-Peer IM communication may be enabled depending on Service Provider policy but it is out of the scope of this document.

For IM server roles in the case of group communication or conference services, the IM Server that owns or hosts the group identity SHALL assume the Controlling IM Function role. Figure 3 depicts the case of a group communication where a 3rd network hosts the conferencing server i.e. chat server in the case of IM, and participants of the chat session are located in different networks.

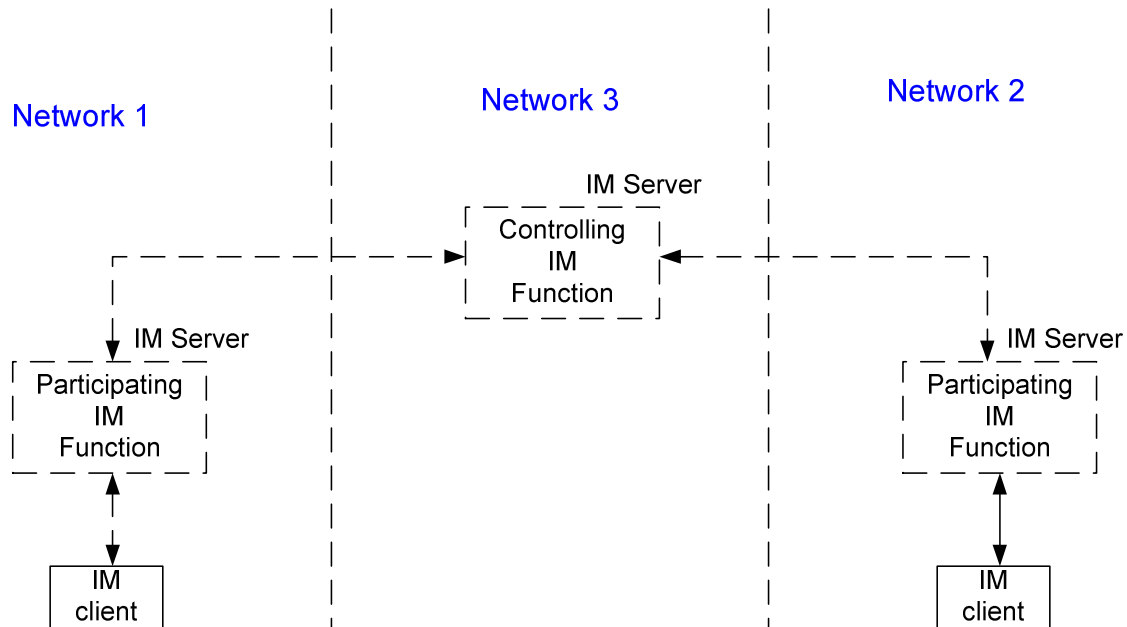

Figure 3: Chat server hosted by Network 3

Distribution by group mechanisms or message explosion is another form of group communication and is categorised as one of the functions under the Controlling IM function see Figure 4

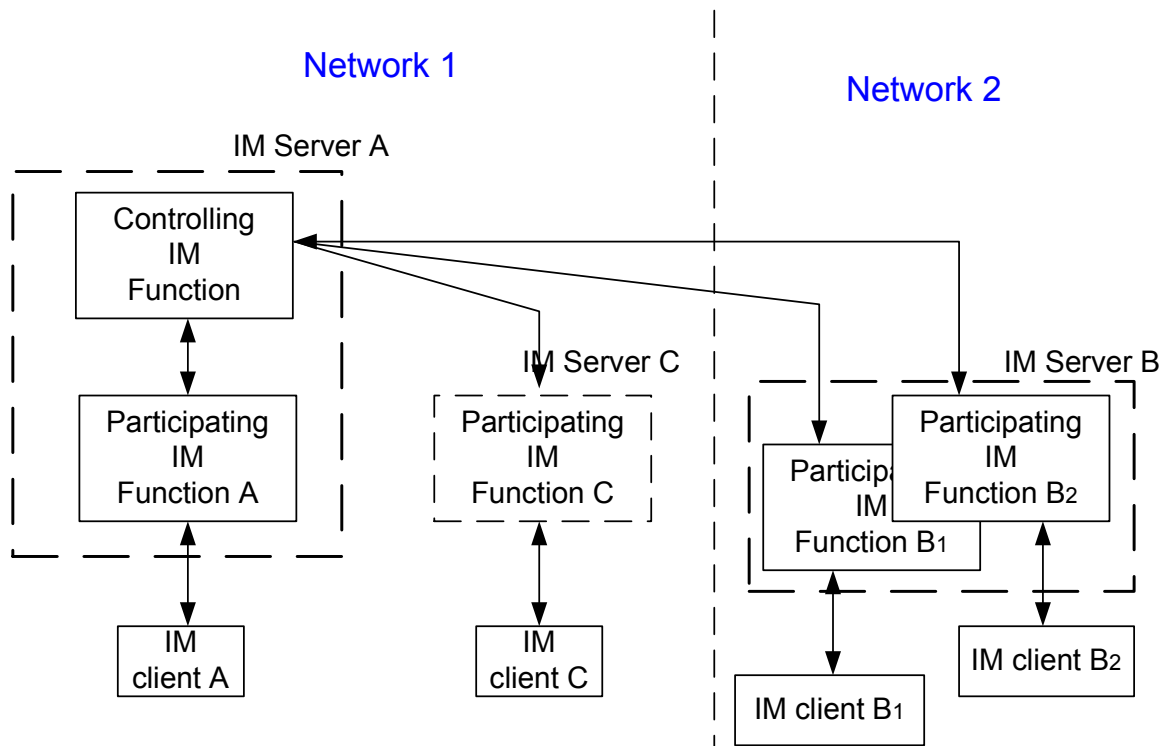

Figure 4: Message distribution by either group mechanism or Uri-list service

In Figure 4 User A (IM Client A) initiates the group communication either by sending a message to a group URI or to a Uri-list service URI. IM Server A assumes the role of Controlling IM Function in this message session since IM Server A has to perform the controlling functions for the group communication i.e. IM Server A does the fan out of the messages to the individual recipients in the URI-list or the members of the group.

5.3.2.1.2 Presence Functionality

The IM Server performing the Participating IM Function MAY act as Presence Source and Watcher towards the Presence Server on behalf of the IM Client. The presence handling is performed via the reference points IM-2 and PRS-3. Communication between IM Server and Presence Server is accomplished using SIP and the SIP specific event notification mechanism as specified in [PRES].

When the IM Server assumes the role of a Presence Source, it SHALL perform the following functions:

- Mapping of dynamic IM status information into Presence attributes describing the availability of the user to communicate via IM Service.
- Publish IM-related presence information to the Presence service (on behalf of IM Client) based on this mapping function.

When the IM Server assumes the role of a Watcher, it SHALL perform the following functions:

- Request presence information from Presence service in order to provide the mediation of presence attributes into meaning for IM Session setup's policy enforcement (e.g. IM Client "not reachable" status, respecting IM Clients manually updated IM presence settings (e.g. appear offline)).

IM Server MAY support policy enforcement for IM handling based on IM-related or general presence information (e.g. status "not reachable").

5.3.2.1.3 Deferred Messaging Function

The Deferred Messaging Function is always associated with the recipient’s terminating Participating IM Server.

IM server performs the Deferred Messaging Function:

- a) When a receiving user is offline or has enabled the setting preference for pager-mode messages to be stored,
- b) When a user in scenario (a) becomes available for IM communication and tries to retrieve stored messages or the IM server tries to push the message to the user.

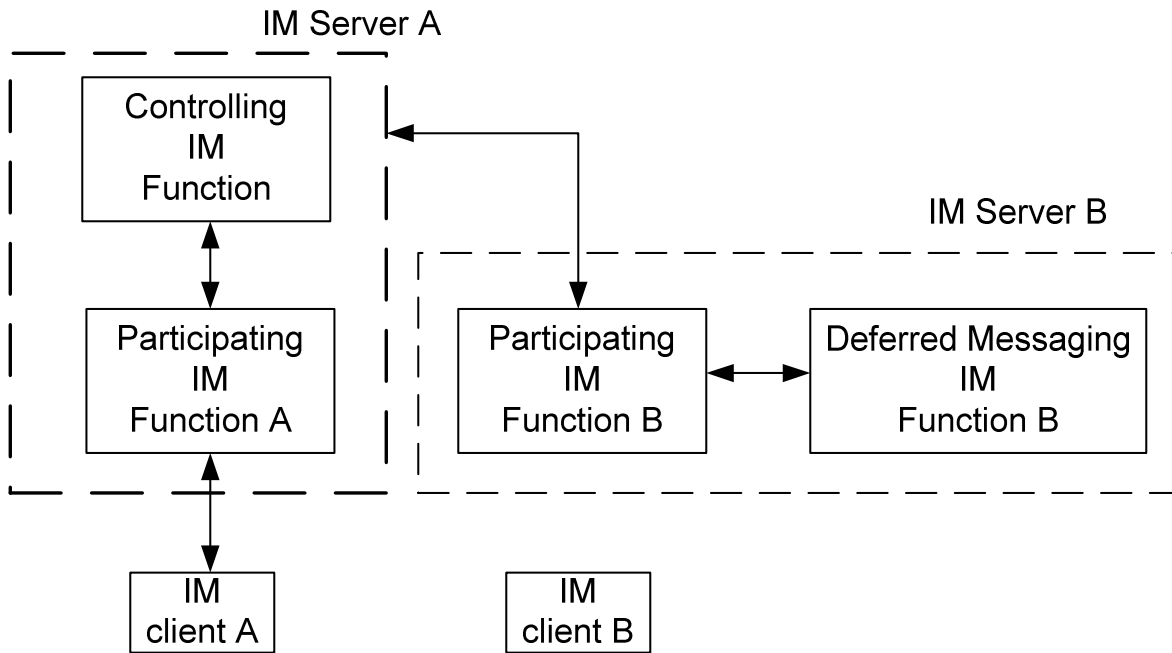

Figure 5: User B is not available for IM and IM Server B activates Deferred Messaging role to store the message

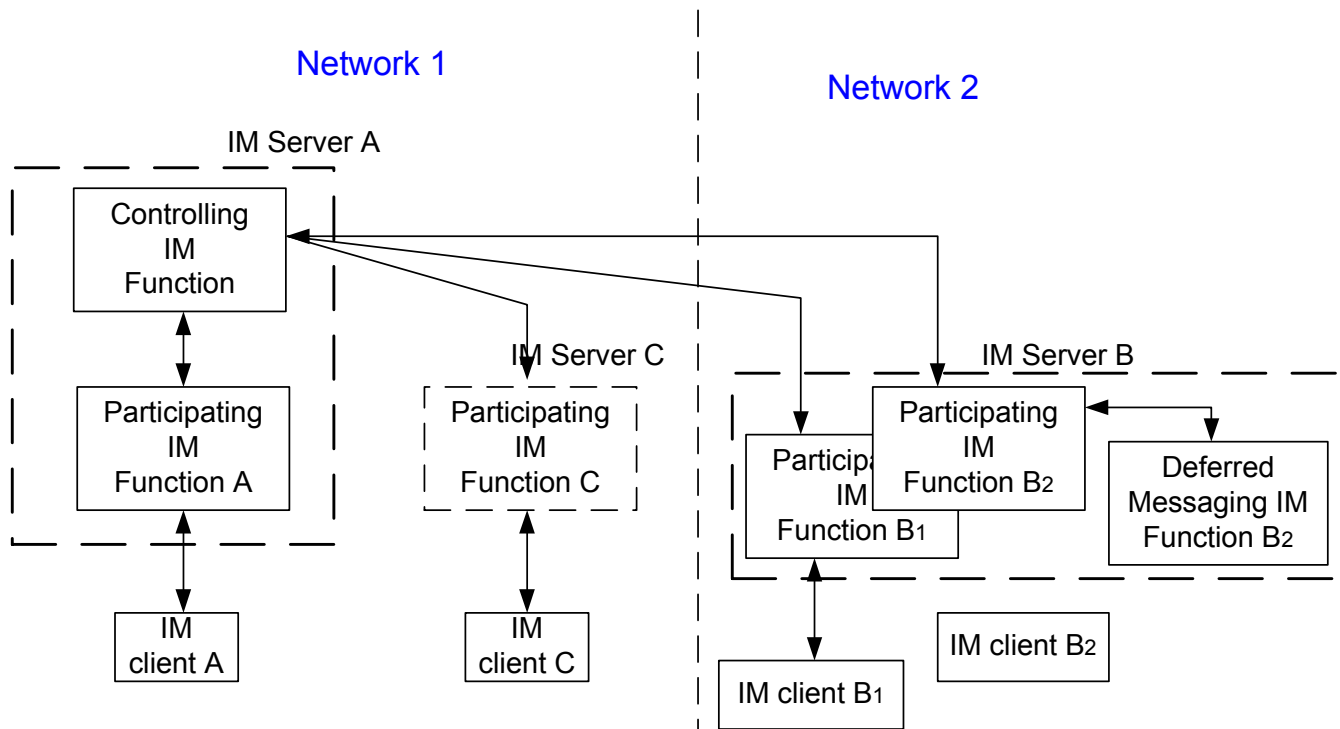

Figure 6: A group distribution from User A when User B2 is Unavailable (Deferred Messaging)

5.3.2.1.4 Conversation History Function

The Conversation History Function is always associated with the Participating IM Function of the user who requested the storage of the conversation.

The IM server performs the Conversation History Function when a user requested the storage of an IM conversation. This can be done by:

- a) An IM service setting to always store conversations for a particular user set by that user
- b) A IM Client initiated request to store a particular conversation

The IM Conversation History Function interacts with the IM XDMS to allow the user to retrieve and manage (e.g. delete, rename) the IM conversation. Note: The meta-data pertaining to an IM conversation is stored in the IM XDMS while the actual IM conversation is stored in the IM Server.

Note: that the stored conversation SHALL only be retrieved by the participants who requested the storage of the conversation. Also note: for the Conversation History function to be enabled in peer-to-peer IM Sessions, the sessions will be modified to non-peer-to-peer sessions.

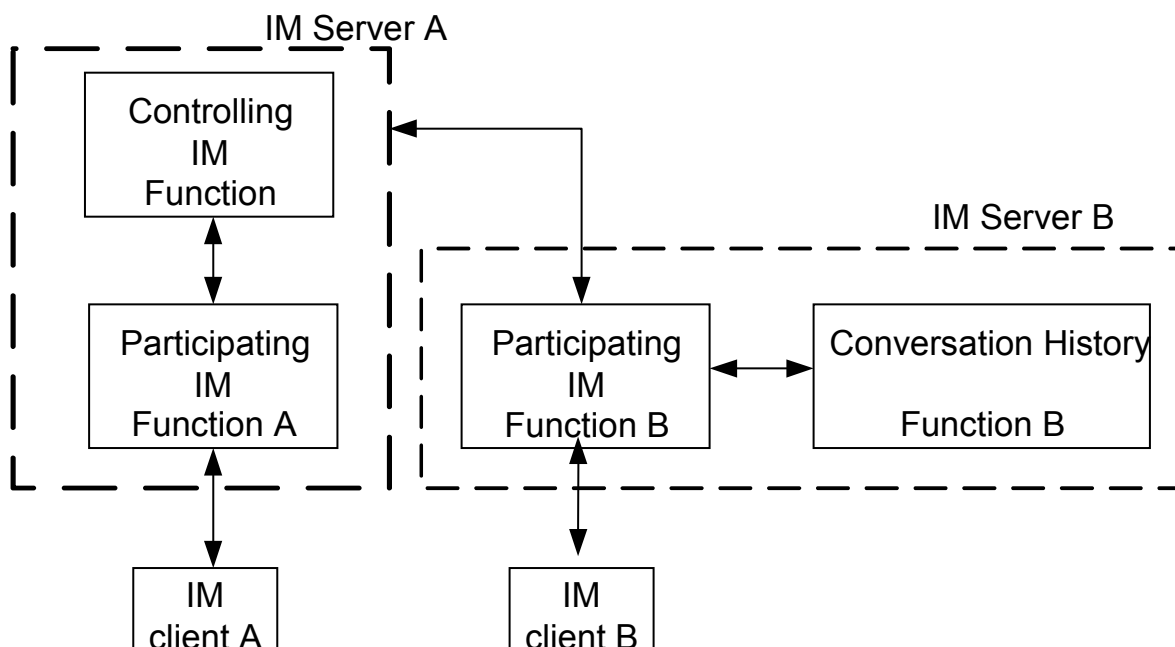

Figure 7: User B has requested the IM Server B to store the conversation

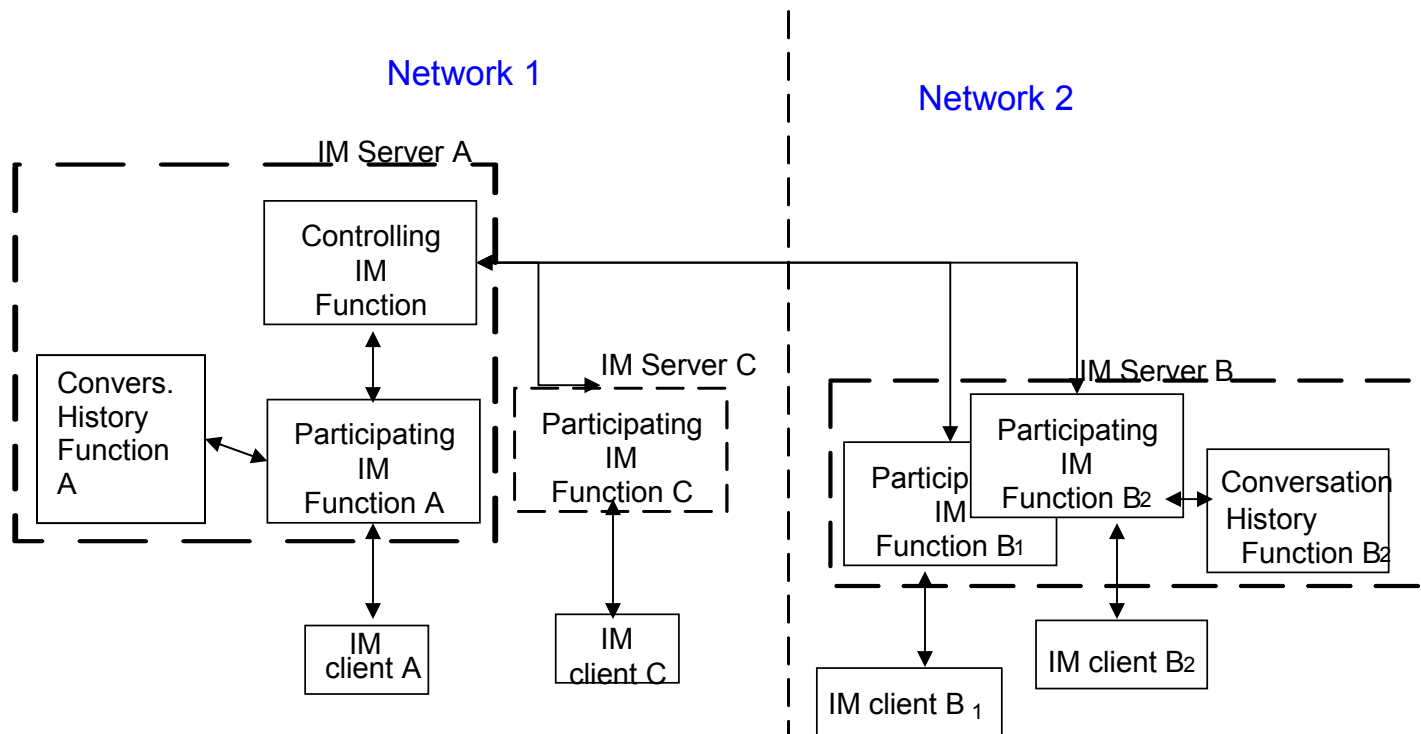

Figure 8: Both User A and User B2 have requested to store the conversation

5.3.2.1.5 Nested Lists and Nested Groups

This document follows the mechanism as defined in [XDM-ERP] whereby a *nested list* is a resource list document that contains either (1) <list> elements that contain other <list> elements directly or (2) <list> elements that contain <external> elements that reference other resource list documents. Nested lists are allowed as long as a resource list document along with any other resource list documents pointed to it by <external> elements are in the same administrative domain.

An IM Group is defined as having a group URI that is comprised of lists or nested lists. A *nested group* is when an IM group contains a URI that points to another IM group URI. During IM message explosion, nested groups may lead to problems when, for example, the first MESSAGE-exploder may send the MESSAGE to the second resource who is also a MESSAGE-exploder. In order to prevent loops, nested groups are not allowed.

The mechanism to prevent nested groups in SIP/SIMPLE IM 1.0 is as follows:

Whenever a Controlling IM Function sends an invitation to a group URI or message to an exploder, the receiving IM Server will recognise that there is already a Controlling IM Function in the transaction and will REJECT the REQUEST. Therefore there can be only one controlling IM functional role in a group session and the service concept of having nested group in an IM group communication is disallowed.

5.3.2.2 OMA IM Conference Model

The conferencing model in this document is limited to ‘tightly coupled’ conferencing model as defined in [3GPP-CONF] and [OMA PoC AD], a subset of the IETF defined generic framework for conferencing services [CONF-Framework]. That means there is a central point of control to which each participant connects. Therefore in general, in every IM group /conference session, there can be only one controlling IM function and one or more participating IM functions.

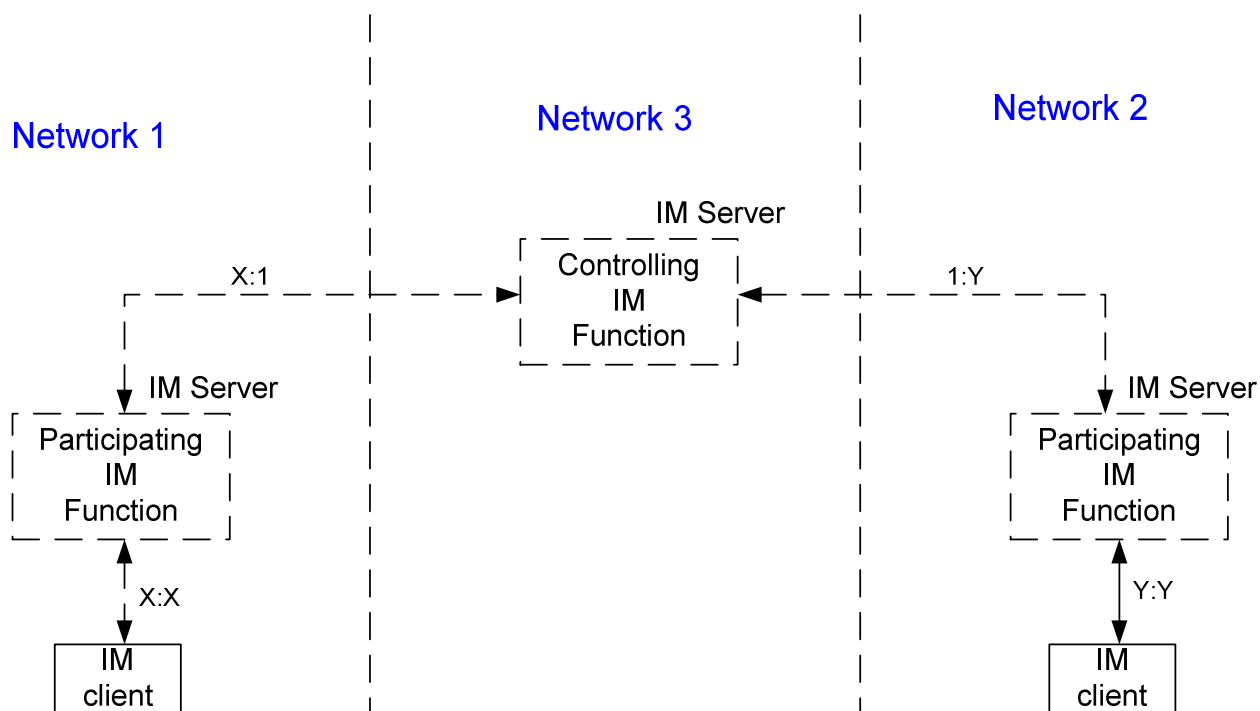

Figure 9: General relationship between Participation IM function, Controlling IM function and IM Clients

The general relationship between the IM functional roles in Figure 9 shows that, in a particular group/conferencing IM session, a Controlling IM functional role, i.e. IM server in Network 3, can manage X +Y number of SIP and media session communication paths.

Where,

- X = number of Participating IM functional roles from Network 1 to the chat server
- Y = number of Participating IM Functional roles from Network 2 to the chat server.
- The ratio between participating IM function role and IM Client is always 1:1.

The variables X and Y, range from 1 to a certain maximum number. The maximum number can be a limit set by the Service Provider.

5.3.2.3 IM Media Stream Path

This section describes all the optional IM media stream path of the MSRP.

5.3.2.3.1 Entities in the User Plane of IM Sessions

Figure 10 shows the entities active in the User Plane in an IM Session and the relevant User Plane interfaces between them.

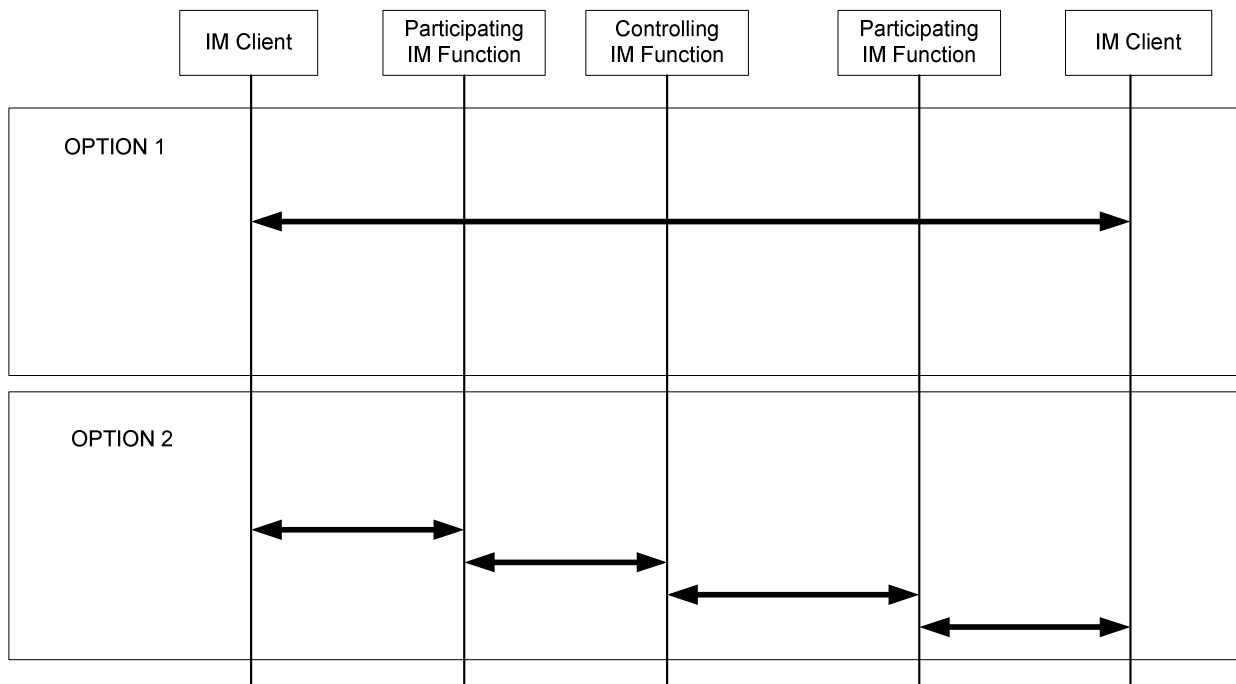

Figure 10: IM media stream path options for IM sessions

OPTION 1 is the case of One-to-One IM session where IM Servers have not inserted themselves in the transport path. In this case the IM Clients are sending MSRP packets directly between them.

This model is only available in Peer-to-Peer IM sessions and when operator does not want to add MSRP relay in the path.

OPTION 2 is the case where the Participating IM Function and Controlling IM Function has inserted itself in the transport path. When the transport path includes the Participating IM Functions, the IM Server performing the Participating IM Function forwards MSRP packets between the IM Client and the IM Server performing the Controlling IM Function. The controlling IM Function sends MSRP packets to the involved participating IM servers.

Examples of when the IM Server performing the participating IM Function is in the transport path are:

- The IM Server needs transport information to support charging;
- The operator has configured the Participating IM Function to be in the transport path;

NOTE 1: When the IM Session is established, the IM Server performing the Participating IM Function Should include itself into the transport path to forward the MSRP packets, but based on operator’s policy Participating IM Functions may decide not to stay in the media path.

NOTE 2: In case of One-to-One IM Session the Controlling IM Function may not be in the media path while participating IM Function are in the media path.

5.3.2.3.2 Entities in the User Plane of Deferred IM

IM communication becomes deferred when the terminating IM Server performing the Participating IM Function accepts an IM on behalf of the terminating offline IM Client. In deferred IM, terminating IM Server is always the end point of the transport path.

Figure 11 shows the entities active in the User Plane of a deferred IM and the relevant User Plane interfaces between them.

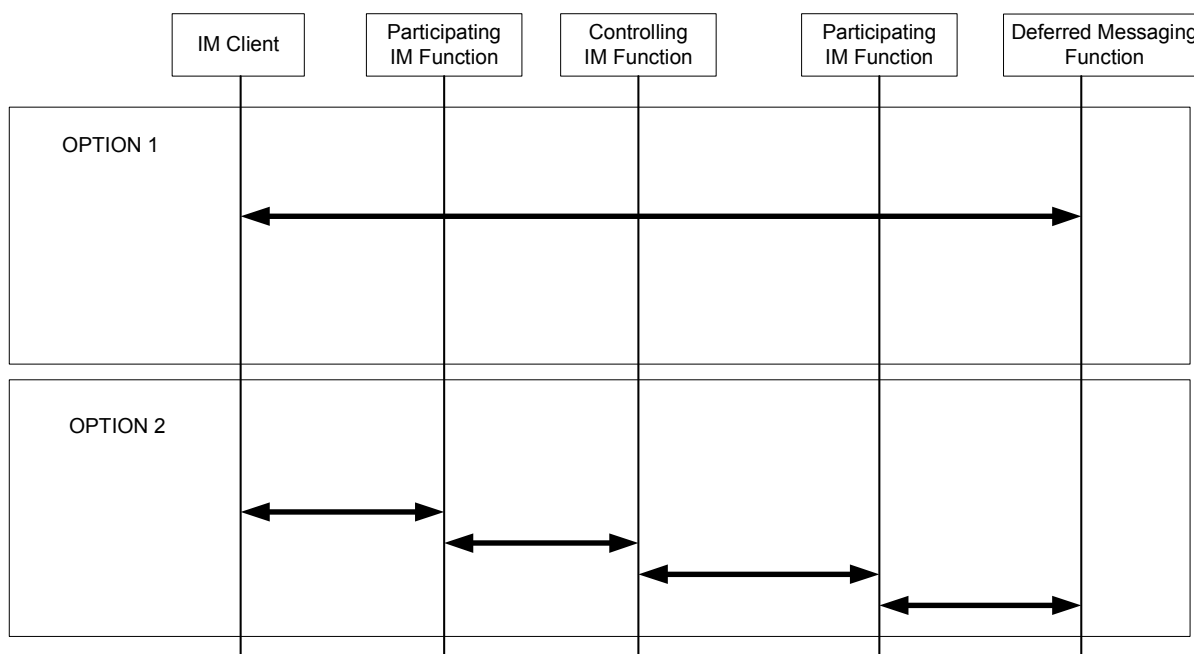

Figure 11: IM media stream path options for Deferred IM

OPTION 1 is the case where there is no other IM server in the transport path apart from the terminating IM Server. In this case the IM Clients are sending MSRP packets directly to the terminating IM Server performing the Deferred Messaging Function.

OPTION 2 is the case where the Participating IM Functions and Controlling IM Function has inserted itself in the transport path.

NOTE 1: When the IM Session is established, the IM Server performing the Participating IM Function SHOULD include itself into the transport path to forward the MSRP packets but based on operator’s policy Participating IM functions may decide not to stay in the media path.

NOTE 2: In case of One-to-One Pager mode or Large Message mode IM the Controlling IM Function may not be in the media path while participating IM Function are in the media path.

5.3.2.3.3 Entities in the User Plane of Conversation History Function

Figure 12 shows the entities active in the User Plane in an IM Session and the relevant User Plane interfaces between them.

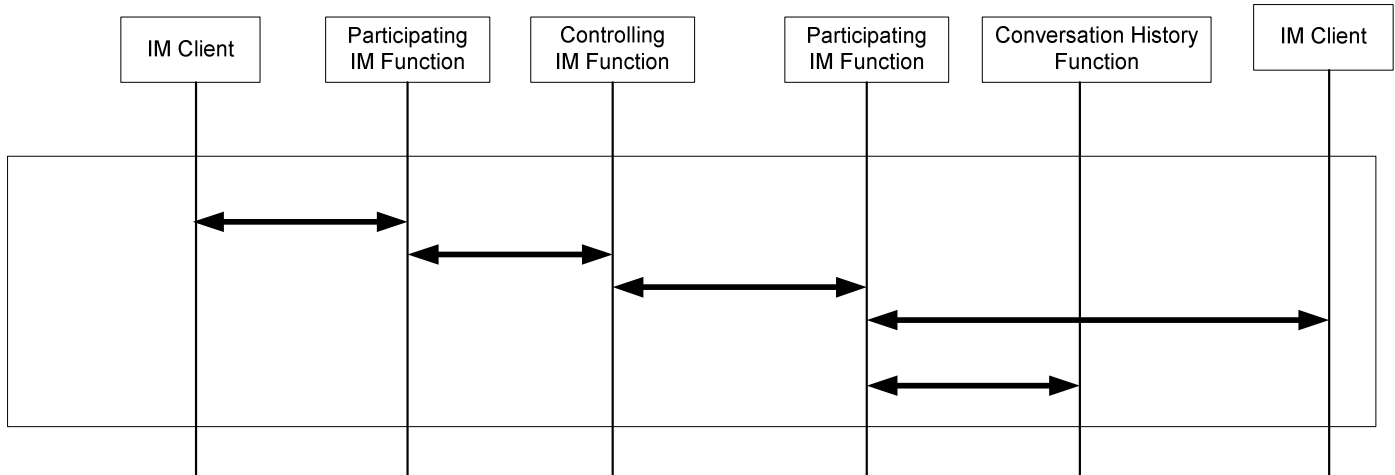

Figure 12: IM media stream path options for storing Conversation History

The IM Server performing the Participating IM Function copies MSRP packets directly to the Conversation History Function.

5.3.2.3.4 Entities in the User plane of Deferred/Conversation History IM delivery

Figure 13 shows the entities active in the User Plane in an IM Session and the relevant User Plane interfaces between them.

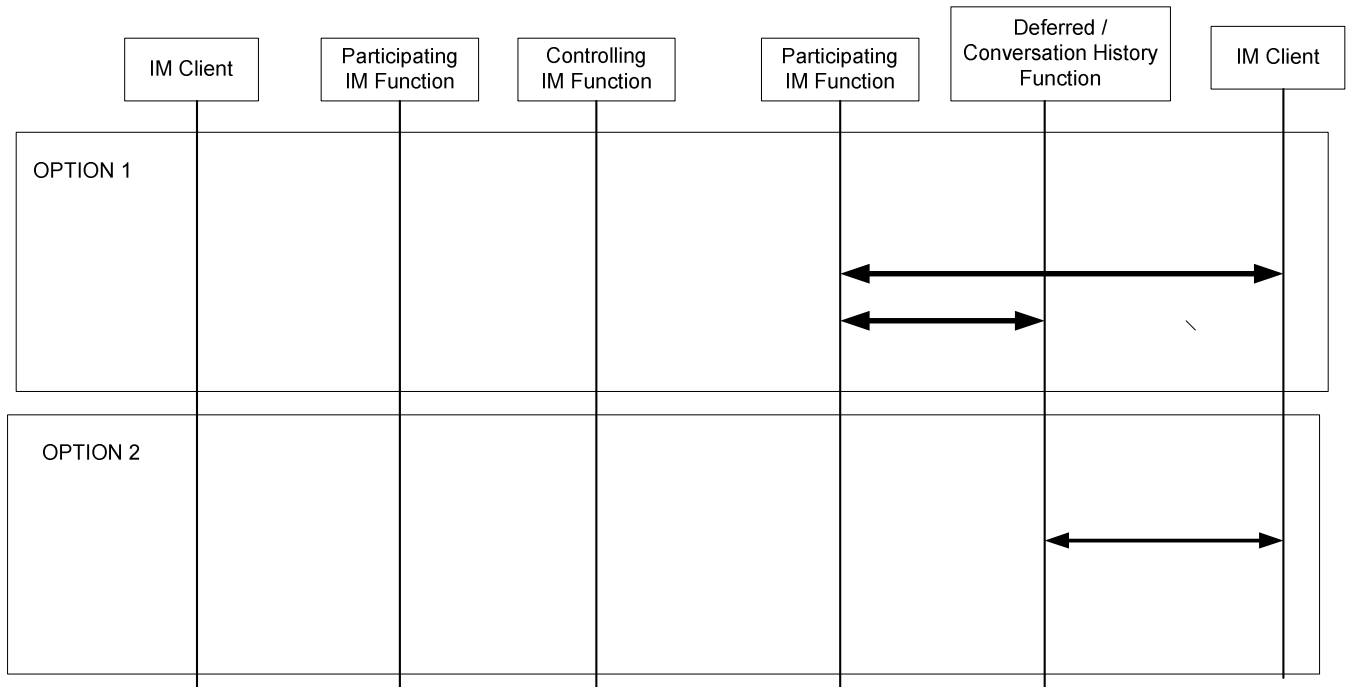

Figure 13: IM media stream path options of Deferred/Conversation History IM delivery

OPTION 1 is the case where the IM Server performing the Participating IM Function has inserted itself in the transport path. The IM Server performing the Participating IM Function forwards MSRP packets between the IM Client and the IM Server performing the Deferred/Conversation History Messaging Function.

OPTION 2 is the case where the IM Servers performing the Deferred/ConversationIM Function sends MSRP packets directly to the IM Client.

5.3.2.4 IM Server Roles

The behaviour of the IM Server can be better described by dividing it logically into a number of roles. Each role is defined as a function with a set of capabilities. The following subclauses describe the roles of Participating, Controlling, Deferred Messaging, and Conversation History Functions. To fulfil all the features of the IM Service, an IM Server must play all of these roles from time to time.

IM Server roles must not be interpreted as physical entities.

5.3.2.4.1 Participating IM Function

An IM server performing a Participating IM Function rule, SHALL perform the following set of functions for a particular active IM session

- SIP session handling
- Policy enforcement for incoming/outgoing IM
 - Service authorisation
 - IM user service profile
 - Preferences, User privacy
 - Message size and content
- Execution of IM message processing configuration and settings
 - Blocklist/ Grantlist, etc
 - Provides message delivery requirements
 - Storage requirements
- Maintains and executes IM Service settings
- Publish presence information on behalf of the IM user, if the IM sever is Presence enabled

Charging reports, MAY be optional, if detailed charging reports are not required in some network

Legal interception, this MAY be optional

When the Participating IM Function is on the IM media path, it SHALL:

- Convey MSRP Media packets between the IM Client and the Controlling IM Function

5.3.2.4.2 Controlling IM Function

An IM server performing Controlling IM Function role, SHALL perform the following set of functions for a particular active IM session::

- Group and Conferencing functionalities
 - Centralised IM Media session handling
 - MSRP switch
 - SIP session handling
 - Conference focus which also hosts the chat URI
 - Policy enforcement for participating in a group

- The group participants information, i.e. maintains the list of participants
- Centralised charging reports MAY be optional, if detailed charging reports are not required by the operator.
- Uri-list service: the explosion and delivery reports (if required) of sessionless/session-based messages i.e. explosion of a SIP MESSAGE/Ad hoc Chat to multiple recipients
- Support SIP conference event package

5.3.2.4.3 Deferred Messaging IM Function

The IM server assuming the role of Deferred Messaging IM Function, SHALL perform the following set of functions for a particular active IM session: , :

- SIP session Handling
- MSRP End Point
- Message storage handling
- Notification about deferred messages when user becomes available for IM communication
- IM Client retrieval interface
- Forwarding/push delivery when user becomes available for IM communication
- Stored message Security
- Storage messaging charging reports

5.3.2.4.4 IM Conversation History Function

The IM server assuming the role of IM Conversation History Function, SHALL perform the following set of functions for a particular active IM session: ,

- SIP session handling
- MSRP End Point
- Conversation storage handling
- Conversation retrieval handling
- Conversation management functionality (e.g. get descriptive information about conversations, delete conversations)
- Provides stored conversation Security
- Provides storage conversation charging reports

5.3.3 IM XML Document Management Server (XDMS)

The IM XDMS is an XCAP Server that manages XML documents (e.g. IM Conversation History and Deferred messages metadata for a user), which are specific to the IM service enabler. Management features include operations such as create, modify, retrieve, and delete.

The IM XDMS SHALL:

- Perform authorization of incoming SIP and XCAP requests.
- Allow storage of descriptive information of stored IM conversations triggered by the IM server

- Maintain reference to the stored IM conversations, that allow these conversations to be managed (resaved, renamed, deleted, etc.).
- Manage XML documents specific to the IM service enabler.
- Accept subscriptions and notify watchers of changes to the stored IM specific documents.

5.4 External Entities Providing Services to IM

Within the context of the OMA Service Environment (OSE) specification [OMA OSE], the IM server interacts with entities that are external to the IM server. These entities MAY be located within the OSE (e.g., Presence, XDMS) or outside the OSE (e.g., SIP/IP-Core). For the interactions of the IM server with these entities, the OSE also provides an optional feature to enforce policy related to authentication. In dealing with these entities and if desired, the OSE provides a policy-based mechanism to manage these interactions through appropriate security mechanism, charging information inquiries, logging and enforcement of user privacy or preferences, etc. The OSE architecture also manages the procedures that can be applied between the IM server and those entities that reside outside the OMA service environment, e.g., IMS capabilities as identified and referenced in the “IMSinOMA” documents [OMA IMS].

NOTE: The SIMPLE IM Server in its current version does not rely on, nor makes any use of, the external functionality provided by the OSE policy enforcement mechanism.

5.4.1 SIP/IP Core

The SIP/IP core includes a number of SIP proxies and SIP registrars. The SIP/IP Core performs the following functions that are needed to support of the IM Enabler:

- Routes SIP signalling between the IM Client and the IM Server
- Provides discovery and address resolution services
- Supports SIP compression
- Performs authentication and authorization of IM Client based on user’s service profile
- Maintains the registration state
- Provides charging information
- Provides capabilities to Lawful Interception.

NOTE: Part of the Lawful Interception functionality MAY be supported by the access network.

The interface to the SIP/IP Core in the IM architecture is not limited to the use of 3GPP and 3GPP2 IMS, and it is open to other SIP core networks. In the context of “IMS in OMA”, the OMA IM SHALL utilize the capabilities of IMS as specified in 3GPP ([3GPP TS 23.228]) and 3GPP2 ([3GPP2 X.P0013.2]) and referenced in the IMSinOMA documents [OMA IMS]. In the context of other networks, a network of SIP proxies and registrars providing the aforementioned functionality MAY be utilized.

5.4.2 XML Document Management Entities

5.4.2.1 Shared List XDMS

The Shared List XDMS is an XCAP Server that manages XML documents containing user lists. The IM Service enabler is able to utilize the shared user lists e.g. in group, Contact Lists and access policy definitions.

The functionality of the Shared List XDMS is described in [XDM-AD].

5.4.2.2 Shared Group XDMS

The Shared Group XDMS is an XCAP Server that allows managing XML documents containing group specific information such as group members and rules for allowed operations and functions.

The functionality of the Shared Group XDMS is described in [XDM-AD].

5.4.2.3 Shared Profile XDMS

The Shared Profile XDMS is an XCAP Server that manages XML documents containing User Profile information. The IM Service enabler is able to utilize the shared user profile information e.g. in searching contacts for IM communication and checking the age of a user.

The functionality of the Shared Profile XDMS is described in [XDM-AD].

5.4.2.4 Shared Policy XDMS

The Shared Policy XDMS is an XCAP Server that manages XML documents containing User's access policy rules.

The functionality of the Shared Policy XDMS is described in [XDM-AD].

5.4.2.5 Aggregation Proxy

The functionality of the Aggregation Proxy is described in [XDM-AD].

5.4.2.6 Search Proxy

The Search Proxy provides a single contact point for the XDM Client to search data stored in XDM Servers.

The functionality of the Search Proxy is described in [XDM-AD].

5.4.2.7 XDM Client (XDMC)

The XDM Client is an XCAP Client, which manages XML documents stored in the network (e.g. IM-specific documents in the IM XDMS, URI lists used as e.g. Contact Lists in the Shared List XDMS, etc). Management features include operations such as create, modify, retrieve, and delete.

The XDMC is also able to subscribe to changes made to XML documents stored in the network, such that it will receive notifications when those documents change. This entity is specified in [XDM-AD].

5.4.3 Presence Entities

5.4.3.1 Presence Server (PS)

The functionality of the Presence Server is described in [PRES-AD].

5.4.3.2 Presence Client Source

The Presence Client Source is an entity that provides (publishes) presence information to a Presence service.

This entity is specified in [PRES-AD].

5.4.3.3 Presence Client Watcher

The Presence Client Watcher is an entity that requests presence information about a Presentity, or Watcher Information about a Watcher, from the Presence service.

This entity is specified in [PRES-AD].

5.4.4 Charging Enabler

The OMA charging model states that its “Charging Enabler” facilitates interaction between various OMA service enablers and the charging functional entity (either offline, online or both), which MAY reside in various domains, e.g., 3GPP/3GPP2 Service Provider [OMA-Charging]. As an external entity residing in the operator's domain this charging entity takes various roles, which service providers need to perform the charging activities.

5.4.5 Device Management Server

This is an external entity, which MAY reside in the service provider's domain. This entity takes various roles, which are needed for remote manipulation of the IM Client mobile device, security and policy to control the access to a particular resource in the mobile device.

5.5 Reference Points

Reference points named IM are related specifically to the IM functionality and they are newly defined and elaborated in this document. In addition, a listing of other relevant reference points using existing or in-progress OMA specified interfaces is provided, e.g., a charging defined reference point CH-x from the IM Enabler to the Charging Enabler.

5.5.1 Reference Point IM-1: IM-Client ↔SIP/IP-Core

The IM-1 reference point supports the communication between the IM Client and the SIP/IP Core. The protocol for the IM-1 reference point is SIP.

This reference point SHALL support the following:

- IM session signaling between the IM Client and the IM server
- Message exchanges between IM Client and the IM server
- Provides discovery and address resolution services
- Provides SIP compression
- Performs authentication and authorization of the IM user at the IM Client based on the IM user's service profile
- Provides IM Client registration
- Publication of IM Client provided service settings (e.g., activating incoming IM barring)
- MIME types

When SIP/IP Core corresponds with 3GPP/3GPP2 IMS, the IM-1 reference point SHALL conform with the Gm reference point [3GPP TS 23.002], [3GPP2 X.P0013.0].

5.5.2 Reference Point IM-2: IM-Server ↔SIP/IP-Core

The IM-2 reference point supports the communication between the SIP/IP core and the IM Server for SIP session control. The protocol for the IM-2 reference point is SIP.

The IM-2 reference point SHALL support the following:

- IM session signaling between the IM Client and the IM server
- Message exchanges between IM Client and the IM server
- Provides address resolution services
- Publication of Presence Information from the IM server to the Presence Server

- Subscription to Presence Information by the IM Server to the Presence Server
- Notification of Presence Information by the Presence Server to the IM Server
- Subscription to the modification of XML documents stored in the IM XDMS or Shared XDMSs
- Notification of modifications made to XML documents stored in the IM XDMS or Shared XDMSs
- Subscription of conference event package from the IM server
- Notification of conference event package to the IM server
- Publication of IM Client provided service settings (e.g., activating incoming IM barring)

When the SIP/IP Core corresponds with 3GPP/3GPP2 IMS, the IM-2 reference point SHALL conform to the ISC reference point [3GPP TS 23.002], [3GPP2 X.P0013.0].

5.5.3 Reference Point IM-3: IM-Server ↔IM XDMS

The IM-3 reference point supports the communication between the IM Server and IM XDMS. The protocol for the IM-3 reference point is XCAP.

The IM-3 reference point SHALL support the following:

- Retrieve IM-specific XML documents.

If the IM service supports Conversation History, the IM-3 reference point SHALL also support:

- Creation of Conversation History specific XML documents.

5.5.4 Reference Point IM-4: IM-Server ↔Shared List XDMS

The IM-4 reference point supports the communication between the IM Server and the Shared List XDMS. The protocol for the IM-4 reference point is XCAP.

The IM-4 reference point SHALL support the following:

- Retrieval of URI Lists from the Shared List XDMS.

5.5.5 Reference Point IM-5: IM XDMS ↔SIP/IP Core

The IM-5 reference point supports communication between the IM XDMS and SIP/IP Core. The protocol for the IM-5 reference point is SIP.

The IM-5 reference point SHALL support the following:

- Subscription to modifications of IM-specific XML documents.
- Notification of the modifications to IM-specific XML documents.

5.5.6 Reference Point IM-6: IM XDMS ↔Aggregation Proxy

The IM-6 reference point supports communication between the IM XDMS and Aggregation Proxy. The protocol for the IM-6 reference point is XCAP.

The IM-6 reference point SHALL support the following:

- IM-specific XML document management (e.g., create, modify, retrieve, delete).

5.5.7 Reference Point IM-7: IM-Client ↔IM-Server

The IM-7 reference point support the communication between the IM Client and the IM Server for session mode messaging within the same domain. The protocol for the IM-7 reference point is MSRP [MSRP]. In an optional configuration, a remote IM Client from a different domain MAY communicate with the IM Server for session mode messaging over this interface.

The IM-7 reference point SHALL support:

- Messaging transportation.
- Support of text based media types.

The IM-7 reference point MAY support the following:

- MIME types.

5.5.8 Reference Point IM-8: IM-Server ↔IM-Server

The IM-8 reference point support the communication between the remote IM Server and the IM Server for session mode messaging across different domains. The protocol for the IM-8 reference point is based on MSRP [MSRP].

The IM-8 reference point SHALL support:

- Messaging transportation.
- Support of text based media types.

The IM-8 reference point MAY support the following:

- MIME types.

5.5.9 Reference Point IM-9: IM-Client ↔Remote IM-Client

The IM-9 reference point supports the direct Peer-to-Peer connection for messaging between IM IClients either in the same domain or in different domains. While IM-7 and IM-8 reference points for the “Via IM Server” solution is “mandatory”, this IM-9 reference point to enable the “direct Peer-to-Peer link” solution is “optional.” The protocol for the IM-9 reference point is MSRP as described in [MSRP]

The IM-9 reference point SHALL support the following:

- One-to-One direct messaging session transportation and context.
- IM Client having different One-to-One IM sessions simultaneously.
- Support of text based media types.

The IM-9 reference point MAY support the following:

- MIME types.

5.5.10 Reference Point IM-10: IM Server ↔Shared Group XDMS

The IM-10 reference point supports communication between the IM Server and the Shared Group XDMS. The protocol for the IM-10 reference point is XCAP.

The IM-10 reference point SHALL support the following:

- Retrieval of group specific information from the Shared Group XDMS.

5.5.11 Reference Point IM-11: IM Server ↔ Shared Profile XDMS

The IM-11 reference point supports communication between the IM Server and the Shared Profile XDMS. The protocol for the IM-11 reference point is XCAP.

The IM-11 reference point SHALL support the following:

- Retrieval of User Profile information from the Shared Profile XDMS.

5.5.12 Reference Point IM-12: IM XDMS ↔ Search Proxy

The IM-12 reference point supports communication between the IM XDMS and the Search Proxy. The protocol for the IM-12 reference point is XCAP.

The IM-12 reference point SHALL support the following:

- Search of information stored at IM XDMS.
-

5.5.13 Reference Point IM-13: IM Server ↔ Shared Policy XDMS

The IM-13 reference point supports communication between the IM Server and the Shared Policy XDMS. The protocol for the IM-13 reference point is XCAP.

The IM-13 reference point SHALL support the following:

Retrieval of user's access policy information from the Shared Policy XDMS

5.5.14 Reference Point IP-1: SIP/IP Core ↔ SIP/IP Core

The IP-1 reference point supports the communication between the SIP/IP Cores. The protocol for the IP-1 reference point is SIP.

The IP-1 reference point SHALL support the following:

- communication and forwarding of SIP signalling messaging between SIP/IP Cores
- transfer of inter-provider charging information.

When SIP/IP Core corresponds with 3GPP/3GPP2 IMS, then the IP-1 reference point SHALL conform to the Mw reference point [3GPP TS 23.002] and [3GPP2 X.P0013.0].

5.5.15 Reference point CH-x: IM Server - Charging Enabler

The CH-x reference point represents reference points from the SIMPLE IM Enabler to the Charging Enabler. These reference points are described in [OMA-Charging].

5.5.16 Reference Point XDM-1: XDM Client – SIP/IP Core

The XDM-1 reference point is described in [XDM-AD].

5.5.17 Reference Point XDM-2: Shared XDMSs – SIP/IP-Core

The XDM-2 reference point is described in [XDM-AD].

5.5.18 Reference Point XDM-3: XDM Client- Aggregation Proxy

The XDM-3 reference point is described in [XDM-AD].

5.5.19 Reference Point XDM-4: Aggregation Proxy – Shared XDMs

The XDM-4 reference point is described in [XDM-AD].

5.5.20 Reference Point XDM-5: XDM Client – Aggregation Proxy

The XDM-5 reference point is described in [XDM-AD].

5.5.21 Reference Point XDM-6: Aggregation Proxy – Search Proxy

The XDM-6 reference point is described in [XDM-AD].

5.5.22 Reference Point XDM-7: Search Proxy – Shared XDMs

The XDM-7 reference point is described in [XDM-AD].

5.5.23 Reference Point PRS-5: Presence Server – Shared List XDM Server

The PRS-5 reference point is described in [PRES-AD].

5.5.24 Reference Point PRS-6: Presence XDM Server – SIP/IP Core

The PRS-6 reference point is described in [PRES-AD].

5.5.25 Reference Point PRS-7: Aggregation Proxy – Presence XDM Server

The PRS-7 reference point is described in [PRES-AD].

5.5.26 Reference Point PRS-8: Presence Server - Presence XDM Server

The PRS-8 reference point is described in [PRES-AD].

5.5.27 Reference Point PRS-1: Presence Source – SIP/IP Core

The PRS-1 reference point is described in [PRES-AD].

5.5.28 Reference Point PRS-2: Presence Watcher – SIP/IP Core network

The PRS-2 reference point is described in [PRES-AD].

5.5.29 Reference Point PRS-3: SIP/IP Core – Presence Server

The PRS-3 reference point is described in [PRES-AD].

5.5.30 Reference Point DM-1: DM Client – DM Server

The DM-1 reference point is described in [OMA DM].

The DM-1 reference point SHALL support the following:

- IM Client configuration, e.g. for presence publication purposes.

6. System Concepts

6.1 Security

The IM service environment must be protected against misuse and attacks and it must provide user privacy. There are several aspects to be considered: Service access control, SIP signalling security in general and protection of user messages/media in SIP MESSAGE and in the User Plane. For user message/media security, source origin authentication is an important feature.

6.1.1 General

The IM Service environment SHOULD rely on / reuse security features/ mechanisms provided by the underlying SIP/IP Core, to e.g. secure the service environment and authenticate users. Such dependence will be the assumed as the basis for the security architecture. The SIP/IP Core is assumed to provide user authentication and integrity and (optionally) confidentiality protection of SIP signaling as defined in [3GPP TS33.203]. When the SIP/IP Core corresponds to 3GPP/3GPP2 IMS, and the User Equipment contains USIM/ISIM or UIM/R-UIM, mutual authentication between the user and the SIP/IP Core SHALL be applied as specified in [3GPP TS 33.203]/[3GPP2 S.R0086-0]. All IM users SHALL be securely authenticated to allow reliable access control to IM services.

The SIP/IP Core also needs to ensure, during registration, that the registered IM users' public and private address is allocated and authorized to be used by that User in order to prevent spoofing attacks as identified in [3GPP TS 33.203]/[3GPP2 S.R0086-0].

Note that the user plane is not a part of the SIP IP Core Security.

6.1.2 Trust Model

The IM trust model for SIP signalling is based on a trusted network model with hop-by-hop security and proxy authentication. In those cases the intradomain security is insufficient; IM servers SHOULD authenticate and secure communication to other servers/proxies according to 3GPP specification [3GPP TS 33.210]. For inter-domain security, IM servers SHALL rely on protected communication channels in the SIP / IP core.

If the IM Server acts as originating UA then the Public User ID of the IM server it MUST support P-Asserted-Identities according to [3GPP TS 24.229].

6.1.3 SIP signalling security

The SIP signalling security mechanisms/features described here cover signalling and user messaging using SIP MESSAGE.

6.1.3.1 Integrity and confidentiality protection

The integrity and optional confidentiality protection mechanism SHALL be used as specified in [3GPP TS 33.203]/ [3GPP2 S.R0086-0].

6.1.3.2 Assurance of user identity

For assurance of user identities and for source origin authentication of SIP Signalling the IM Service SHALL use P-Asserted-Identities according to [3GPP TS 24.229] in this release.

If the IM Server acts as an originating UA then it MUST support P-Asserted-Identities according to [3GPP TS 24.229].

6.1.3.3 SIP MESSAGE Security

In particular, a SIP MESSAGE SHALL be secured according to [3GPP TS 33.203], [3GPP TS 33.210].and [3GPP TS 24.229].

6.1.4 User Plane security

The IM service User Plane communication between IM Client and IM Client, IM Client and IM Server, and between IM Servers SHOULD be protected to support the integrity and confidentiality of the communication. Such protection is not provided by the SIP/IP Core according to IMS for 3GPP(2).

6.1.5 Relation between SIP Signalling and User Plane Security

The security model requires that user authentication and SIP Sessions MUST be securely coupled to the corresponding User Plane communications to ensure that the user identity / source origin is the same in both instances.

6.1.5.1 Denial of Services

The IM Server SHOULD mitigate and warn for Denial of Service in SIP Signalling and User Plane when appropriate

6.1.6 XDMS Security

The XDMS security model is based on IM user authentication for access control and protection of the communication between the user and the Aggregation Proxy.

The XDMS security and Privacy model is described in [PRES-AD] and in [XDM-AD].

6.2 Authorization

The SIP/IP Core may authorize a user to access a particular service such as IM. However, the enabler SHOULD make the authorization decisions on what features within the IM service the user is entitled to. Thus, the SIP/IP Core and the IM enabler can both make authorization decisions, at different granularities. However, the service SHOULD make an authorization decision of what the user is entitled to do.

The same applies to XDMS, where the AP SHALL make an authorization decision if the user may access the IM service, while the IM service SHALL make an authorization decision of what the user may do.

6.3 Privacy

An IM User MAY request privacy for the identity of the IM User meaning that the IM Address of the IM User is hidden from other IM Users. The IM Client SHALL use mechanisms defined in [3GPP TS 24.229] to request privacy.

If an inviting, invited or joining IM User requests privacy of his IM Address then the following procedures SHALL take place in the system operating in the trusted domain(s):

- The IM Server performing the Controlling IM Function SHALL retain privacy information of the IM Participants for the duration of the IM Session.
- The SIP/IP Core serving the invited IM User SHALL provide the privacy of the IM Address of the inviting IM User on Control Plane at the IM-1 reference point.
- The IM Server performing the Controlling IM Function SHALL provide the privacy of the IM Addresses of IM Participants when providing the IM Participant information notifications.
- The IM Server performing the Controlling IM Function SHALL provide the privacy of the IM Address of the talking IM User at the IM-3 and IM-4 reference points.

If privacy for the identity is not requested then IM Servers and SIP/IP Core passes the IM Address of the inviting IM User to the invited IM User.

If privacy for the identity is not allowed in the IM Group authorization rules as specified in [IM XDM Specification], the involved entity SHALL reject the request.

When SIP/IP Core corresponds with 3GPP/3GPP2 IMS then privacy mechanisms as defined in [3GPP TS 24.229]/ [3GPP2 X.S0013.4] are used.

User's Personal Information SHALL be protected by adequate security.

6.3.1 XDMS Security and Privacy

The XDMS security model is based up authentication and encryption done by the Aggregation Proxy (AP)

The XDMS security and Privacy model is described in [PRES-AD] and in [XDM-AD].

6.4 Lawful Intercept

6.4.1 Reference point LI-1: Functional Entities – Law Enforcement Monitoring Facility

The LI-1 reference point supports the communication between functional entities and Law Enforcement Monitoring Facilities. The LI-1 reference point uses protocols defined by applicable LI specifications that transport the LI information to Law Enforcement Monitoring Facilities. The definition of these LI protocols is outside the scope of this specification.

When the SIP/IP Core corresponds with 3GPP IMS, the LI-1 reference point SHALL conform to the HI1, HI2 and HI3 reference points in [3GPP TS 33.107]

Note that the LI-1 reference point is not shown in Figure 1 because it is transparent to the IM enabler

Appendix A. Change History

(Informative)

A.1 Approved Version History

Reference	Date	Description
n/a	n/a	No prior version

A.2 Draft/Candidate Version 1.0 History

Document Identifier	Date	Sections	Description
Draft Versions OMA-AD_IM_SIMPLE-V1_0_0	07 Sep 2004	All	Entire document deleted and replaced with empty template as per: OMA-IM-2004-0153 Incorporates accepted CRs: OMA-IM-2004-0158 OMA-IM-2004-0202 OMA-IM-2004-0203 OMA-IM-2004-0204 OMA-IM-2004-0205 OMA-IM-2004-0208
	10 Dec 2004		Incorporates accepted CRs: OMA-IM-2004-0281R01 OMA-IM-2004-0282R01 Editor action item to include note about "offline IM msg flows"
	10 Feb 2005		Incorporates accepted CRs: OMA-IM-2005-0018R02 OMA-IM-2005-0040R01
	28 Feb 2005	All	Entire document converted to template OMA-Template-ArchDoc-20050121-I Incorporates accepted CR: OMA-IM-2005-0095
	06 Apr 2005		Incorporates accepted CR: OMA-IM-2005-00127R02 OMA-IM-2005-0152R01
	29 Apr 2005		Incorporates accepted CR: OMA-IM-2005-0207 OMA-IM-2005-0208R01 OMA-IM-2005-0216R01 OMA-IM-2005-0217 OMA-IM-2005-0218R01 OMA-IM-2005-0219R01
	Draft Versions OMA-AD-IM_SIMPLE-V1_0-0	21 May 2005	
02 Jun 2005			Incorporates accepted CR: OMA-IM-2005-0316R01 OMA-IM-2005-0322R01 OMA-IM-2005-0323R01 OMA-IM-2005-0329R01 OMA-IM-2005-0332
05 Aug 2005			Incorporates accepted CR: OMA-IM-2005-0320R01 OMA-IM-2005-0465R01
19 Aug 2005			Incorporates accepted CR: OMA-IM-2005-0319R03

Document Identifier	Date	Sections	Description
Draft Versions OMA-AD-IM_SIMPLE-V1_0_0	02 Sep 2005		Missed some changes in OMA-IM-2005-0319R03 Incorporates accepted CR: OMA-IM-2005-0501R02 OMA-IM-2005-0583 OMA-IM-2005-0612R01
	23 Sep 2005		Incorporates accepted CR: OMA-IM-2005-0638R01 OMA-IM-2005-0636R02 OMA-IM-2005-0639R01 OMA-IM-2005-0648R01
	27 Oct 2005		Incorporates accepted CR: OMA-IM-2005-0673R01 OMA-IM-2005-0678R01 OMA-IM-2005-0681R01 OMA-IM-2005-0682R01 OMA-IM-2005-0683
	16 Nov 2005		Incorporates accepted CR: OMA-IM-2005-0633R04 OMA-IM-2005-0687R01 OMA-IM-2005-0708R02 OMA-IM-2005-0722R02 OMA-IM-2005-0724R01c OMA-IM-2005-0725R01 OMA-IM-2005-0727R01 OMA-IM-2005-0729R02 OMA-IM-2005-0731R01 OMA-IM-2005-0732R01
	30 Nov 2005		Editor Actions: Editor Action Items from OMA-IM-0748-MINUTES_29Nov2005CC: AIs #34, 38, 39, 40, 41, 43, 44 Other editorial fixes by the Editor Incorporates accepted CR: OMA-IM-2005-0762 OMA-IM-2005-0739 OMA-IM-2005-0740 OMA-IM-2005-0742R01 OMA-IM-2005-0744R01 OMA-IM-2005-0745R01
	17 Jan 2006		Editor Actions: Update definitions based on e-mail discussion. Incorporates accepted CR: OMA-IM-2005-0743R01 OMA-IM-2005-0750R02 OMA-IM-2005-0781
	16 May 2006		Error (ignore)
	17 May 2006		Incorporates accepted CR: OMA-IM-2005-0743R01 OMA-IM-2005-0750R02 OMA-IM-2005-0781 OMA-IM-2006-0202R01 OMA-IM-2006-0209 OMA-IM-2006-0213R01 OMA-IM-2006-0220 OMA-IM-2006-0244

Document Identifier	Date	Sections	Description
Draft Versions OMA-AD-IM_SIMPLE-V1_0	11 Oct 2006	All	Incorporates accepted CR: OMA-IM-2006-0310R01 OMA-IM-2006-0362R01 OMA-IM-2006-0385R01 OMA-IM-2006-0389
	28 Oct 2006	All	Incorporates accepted CR: OMA-IM-2006-0426
	07 Nov 2006	All	Editorial clean-up of references and styles.
	29 Nov 2006	Title page	Functional name changed to SIMPLE IM.
	13 June 2007	All	Incorporates accepted CR: OMA-IM-2007-0610R01 OMA-IM-2007-0362 OMA-IM-2006-0545 All AD CONNRs Comments resolved in OMA-IM-2007-0286- CR_Implementing_the_resolution_of_IM_AD_CONRRs,
	18 Jul 2007	All	Change template to 2007
	19 Jul 2007		Incorporates accepted CR: OMA-IM-2007-0298
Candidate Versions: OMA-AD-SIMPLE_IM-V1_0	16 Aug 2007	n/a	Status changed to Candidate TP doc #: OMA-TP-2007-0301R02- INP_SIMPLE_IM_ERP_for_Candidate_approval