



Secure User Plane Location Architecture

Candidate Version 3.0 – 08 Mar 2011

Open Mobile Alliance
OMA-AD-SUPL-V3_0-20110308-C

Use of this document is subject to all of the terms and conditions of the Use Agreement located at <http://www.openmobilealliance.org/UseAgreement.html>.

Unless this document is clearly designated as an approved specification, this document is a work in process, is not an approved Open Mobile Alliance™ specification, and is subject to revision or removal without notice.

You may use this document or any part of the document for internal or educational purposes only, provided you do not modify, edit or take out of context the information in this document in any manner. Information contained in this document may be used, at your sole risk, for any purposes. You may not use this document in any other manner without the prior written permission of the Open Mobile Alliance. The Open Mobile Alliance authorizes you to copy this document, provided that you retain all copyright and other proprietary notices contained in the original materials on any copies of the materials and that you comply strictly with these terms. This copyright permission does not constitute an endorsement of the products or services. The Open Mobile Alliance assumes no responsibility for errors or omissions in this document.

Each Open Mobile Alliance member has agreed to use reasonable endeavors to inform the Open Mobile Alliance in a timely manner of Essential IPR as it becomes aware that the Essential IPR is related to the prepared or published specification. However, the members do not have an obligation to conduct IPR searches. The declared Essential IPR is publicly available to members and non-members of the Open Mobile Alliance and may be found on the “OMA IPR Declarations” list at <http://www.openmobilealliance.org/ipr.html>. The Open Mobile Alliance has not conducted an independent IPR review of this document and the information contained herein, and makes no representations or warranties regarding third party IPR, including without limitation patents, copyrights or trade secret rights. This document may contain inventions for which you must obtain licenses from third parties before making, using or selling the inventions. Defined terms above are set forth in the schedule to the Open Mobile Alliance Application Form.

NO REPRESENTATIONS OR WARRANTIES (WHETHER EXPRESS OR IMPLIED) ARE MADE BY THE OPEN MOBILE ALLIANCE OR ANY OPEN MOBILE ALLIANCE MEMBER OR ITS AFFILIATES REGARDING ANY OF THE IPR'S REPRESENTED ON THE “OMA IPR DECLARATIONS” LIST, INCLUDING, BUT NOT LIMITED TO THE ACCURACY, COMPLETENESS, VALIDITY OR RELEVANCE OF THE INFORMATION OR WHETHER OR NOT SUCH RIGHTS ARE ESSENTIAL OR NON-ESSENTIAL.

THE OPEN MOBILE ALLIANCE IS NOT LIABLE FOR AND HEREBY DISCLAIMS ANY DIRECT, INDIRECT, PUNITIVE, SPECIAL, INCIDENTAL, CONSEQUENTIAL, OR EXEMPLARY DAMAGES ARISING OUT OF OR IN CONNECTION WITH THE USE OF DOCUMENTS AND THE INFORMATION CONTAINED IN THE DOCUMENTS.

© 2011 Open Mobile Alliance Ltd. All Rights Reserved.

Used with the permission of the Open Mobile Alliance Ltd. under the terms set forth above.

Contents

1.	SCOPE (INFORMATIVE)	5
2.	REFERENCES	6
2.1	NORMATIVE REFERENCES	6
2.2	INFORMATIVE REFERENCES	7
3.	TERMINOLOGY AND CONVENTIONS	8
3.1	CONVENTIONS	8
3.2	DEFINITIONS	8
3.3	ABBREVIATIONS	9
4.	INTRODUCTION (INFORMATIVE)	12
4.1	VERSION 1.0	12
4.2	VERSION 2.0	13
4.3	VERSION 3.0	14
5.	ARCHITECTURAL MODEL	15
5.1	DEPENDENCIES	15
5.2	ARCHITECTURAL DIAGRAM	15
5.2.1	Communication Mechanisms and Interfaces Covered by Lup	16
5.2.2	SUPL System and Subsystem Descriptions	17
5.3	FUNCTIONAL COMPONENTS AND INTERFACES/REFERENCE POINTS DEFINITION	19
5.3.1	SUPL Location Services Functional Group	19
5.3.2	SUPL Positioning Functional Group	23
5.3.3	SUPL Reference Point Definitions	24
5.4	SECURITY CONSIDERATIONS	25
5.4.1	Authentication	25
5.4.2	Providing the H-SLP Address to the SET	25
5.4.3	Confidentiality and Data Integrity	25
APPENDIX A.	CHANGE HISTORY (INFORMATIVE)	26
A.1	APPROVED VERSION HISTORY	26
A.2	DRAFT/CANDIDATE VERSION <CURRENT VERSION> HISTORY	26
APPENDIX B.	LUP REFERENCE POINT FLOWS (INFORMATIVE)	27
B.1	SET INITIATED FLOWS – IMMEDIATE SERVICE – NON ROAMING	27
B.2	NETWORK INITIATED FLOWS – IMMEDIATE SERVICE – NON ROAMING	28
B.3	NETWORK INITIATED TRIGGERED SERVICES: PERIODIC TRIGGERS – NON ROAMING	30
B.4	NETWORK INITIATED TRIGGERED SERVICES: AREA EVENT TRIGGERS – NON ROAMING	32
B.5	NETWORK INITIATED FLOWS – IMMEDIATE SERVICE – ROAMING	34
B.6	SET-INITIATED GSS – NON ROAMING	35
B.7	NETWORK-INITIATED GSS – NON ROAMING	37
APPENDIX C.	LLP REFERENCE POINT FLOWS (INFORMATIVE)	39
C.1	SET INITIATED – IMMEDIATE FIX – NON-ROAMING	39
C.2	NETWORK INITIATED – IMMEDIATE FIX – NON-ROAMING	40

Figures

Figure 1:	SUPL Architecture	16
Figure 2:	The “Entering” Trigger with Repeated Reporting	22
Figure 3:	The “Inside” Trigger with Repeated Reporting	22
Figure 4:	SET Starting Inside Target Area for both “Entering” and “Inside” Triggers	22
Figure 5:	The “Leaving” Trigger with Repeated Reporting	23

Figure 6: The “Outside” Trigger with Repeated Reporting23

Figure 7: SET-Initiated Non-Roaming27

Figure 8: Network Initiated Non-Roaming28

Figure 9: Network Initiated Periodic Triggered Service Non-Roaming30

Figure 10: Network Initiated Area Event Triggered Service Non-Roaming.....32

Figure 11: Network Initiated Roaming.....34

Figure 12: SET Initiated GSS35

Figure 13: Network Initiated GSS.....37

Figure 14: SET Initiated Non-Roaming Immediate Fix with Llp Interface39

Figure 15: Network Initiated Non-Roaming Immediate Fix with Llp Interface.....40

Tables

Table 1: Allocation of SUPL Functions to SUPL Subsystems19

1. Scope (Informative)

The scope of the Secure User Plane Location (SUPL) architecture document is to define the architecture for the SUPL service enabler.

A reference architecture is defined including:

- Architecture Diagram
- Functional blocks
- Logical entities
- Reference Points / Interfaces
- Messages and message flows

This architecture is based on the requirements listed in the SUPL Requirements document [SUPL RD].

2. References

2.1 Normative References

- [3GPP LTE] 3GPP TS 36.331 "Evolved Universal Terrestrial Radio Access (E-UTRA); Radio Resource Control (RRC); Protocol specification"
URL: <http://www.3gpp.org/>
- [3GPP LPP] 3GPP TS 36.355 "Evolved Universal Terrestrial Radio Access (E-UTRA); LTE Positioning Protocol (LPP)"
URL: <http://www.3gpp.org/>
- [3GPP2 C.S0022-0] 3GPP2 C.S0022-0 v3.0, "Position Determination Service for cdma2000 Spread Spectrum Systems" April 2001
URL: <http://www.3gpp.org/>
- [3GPP2 C.S0022-A] 3GPP2 C.S0022-A v1.0: "Position Determination Service Standard for Dual Mode Spread Spectrum Systems" March 2004
URL: <http://www.3gpp2.org>
- [3GPP2 C.S0022-B] 3GPP2 C.S0022-B v2.0: "Position Determination Service for cdma2000 Spread Spectrum Systems" October 2010
URL: <http://www.3gpp2.org>
- [3GPP2 HRPD] 3GPP2 C.S0024-A Version v3.0; "cdma2000 High Rate Packet Data Air Interface Specification" September 2006
URL: <http://www.3gpp2.org>
- [3GPP2 UMB] 3GPP2 C.S0084-006 v2.0, "Connection Control Plane for Ultra Mobile Broadband (UMB) Air Interface Specification"
URL: <http://www.3gpp2.org>
- [OMA ILP] "Internal Location Protocol", Version 3.0, Open Mobile Alliance™, OMA-TS-ILP-V3_0
URL: <http://www.openmobilealliance.org/>
- [OMA LOCSIP] "Location in SIP/IP core Specification", Version 1.0, Open Mobile Alliance™, OMA-TS-LOCSIP-V1_0
URL: <http://www.openmobilealliance.org/>
- [OMA MLP 3.3] "Mobile Location Protocol", Version 3.3, Open Mobile Alliance™, OMA-TS-MLP-V3_3
URL: <http://www.openmobilealliance.org/>
- [OMA RLP 1.0] "Inter-Location Server Interface Specification", Version 1.0, Open Mobile Alliance™, OMA-TS-RLP-V1_0
URL: <http://www.openmobilealliance.org/>
- [OMA RLP 1.1] "Inter-Location Server Interface Specification", Version 1.1, Open Mobile Alliance™, OMA-TS-RLP-V1_1
URL: <http://www.openmobilealliance.org/>
- [OMA ULP] "UserPlane Location Protocol", Version 3.0, Open Mobile Alliance™, OMA-TS-ULP-V3_0
URL: <http://www.openmobilealliance.org/>
- [OMA LPPe] "LPP Extension Specification", Version 1.0, Open Mobile Alliance™, OMA-TS-LPPE-V1_0,
URL: <http://www.openmobilealliance.org/>
- [PSK-TLS] "Pre-Shared Key Ciphersuites for Transport Layer Security (TLS)", IETF RFC 4279, December 2005
URL: <http://www.ietf.org/rfc/rfc4279.txt>
- [RFC2119] "Key words for use in RFCs to Indicate Requirement Levels", S. Bradner, March 1997
URL: <http://www.ietf.org/rfc/rfc2119.txt>
- [SUPL RD] "Secure User Plane Requirements", Version 3.0, Open Mobile Alliance™, OMA-RD-SUPL-V3_0
URL: <http://www.openmobilealliance.org/>
- [SIP PUSH] "SIP_Push", Version 1.0, Open Mobile Alliance™, OMA-ERP_SIP_PUSH-V1_0
URL: <http://www.openmobilealliance.org/>
- [TLS] "Transport Layer Security (TLS) Version 1.1", IETF RFC 4346, April 2006
URL: <http://www.ietf.org/rfc/rfc4346.txt>

[WAP PAP]	“Push Access Protocol”, Version 2.2, Open Mobile Alliance™. OMA_WAP-TS-PAP V2_2 URL: http://www.openmobilealliance.org/
[WAP POTAP]	“Push Over The Air”, Version 2.2, Open Mobile Alliance™. OMA_TS-PushOTA-V2_2 URL: http://www.openmobilealliance.org/
[WAP PUSH]	“Push Message”, Open Mobile Alliance™. OMA WAP-251-PushMessage URL: http://www.openmobilealliance.org/

2.2 Informative References

[3GPP GSM LCS]	3GPP TS 43.059, “Functional stage 2 description of Location Services (LCS) in GERAN” URL: http://www.3gpp.org/
[3GPP TS 23.271]	3GPP TS 23.271: “Functional stage 2 description of Location Services (LCS)” URL: http://www.3gpp.org/
[3GPP WCDMA LCS]	3GPP TS 25.305, “Stage 2 functional specification of User Equipment (UE) positioning in UTRAN” URL: http://www.3gpp.org/
[3GPP2 X.S0024-0]	3GPP2 X.S0024-0 v1.0, “IP-Based Location Services”, November 2005 URL: http://www.3gpp2.org/
[ARCH-PRINC]	“OMA Architecture Principles”, Version 1.2, Open Mobile Alliance™, OMA-ArchitecturePrinciples-V1_2, URL: http://www.openmobilealliance.org/
[OMA-DICT]	“Dictionary for OMA Specifications”, Version 2.8, Open Mobile Alliance™, OMA-Dictionary-V2_8, URL: http://www.openmobilealliance.org/
[SUPL MO]	“OMA SUPL Management Object”, Version 1.0, Open Mobile Alliance™, OMA-TS-SUPL-MO-V1_0, URL: http://www.openmobilealliance.org/

3. Terminology and Conventions

3.1 Conventions

The key words “MUST”, “MUST NOT”, “REQUIRED”, “SHALL”, “SHALL NOT”, “SHOULD”, “SHOULD NOT”, “RECOMMENDED”, “MAY”, and “OPTIONAL” in this document are to be interpreted as described in [RFC2119].

All sections and appendixes, except “Scope” and “Introduction”, are normative, unless they are explicitly indicated to be informative.

3.2 Definitions

Control Plane	This plane has a layered structure and performs the call control and connection control functions; it deals with the signaling necessary to set up, supervise and release calls and connections.
Emergency IMS Core	IMS core network supporting emergency IMS call. The main components of Emergency IMS Core are P-CSCF and E-CSCF.
End User Device	See [OMA-DICT].
ImmediateService	Location service where a single location information is needed immediately.
Interface	The common boundary between two associated systems. See [OMA-DICT]
Location Based Application	See [3GPP TS 23.271].
Location (Based) Service	See [3GPP TS 23.271] [3GPP GSM LCS][3GPP WCDMA LCS][3GPP2 X.S0024-0].
MLS Application	An application that requests and consumes the location information.
Non-Proxy Mode	The SPC system will have direct communication with the SET.
Periodic Triggered Service	Location service where a multiple periodic location information is needed.
Proxy Mode	The SPC system will not have direct communication with the SET. In this environment the SLC system will act as a proxy between the SET and the SPC.
Quality of Position	A set of attributes associated with a request for the geographic position of a SET. The attributes include the required horizontal accuracy, vertical accuracy, maximum location age, and response time of the SET position.
Reference Point	See [OMA-DICT]
SET Initiated Services	SET Initiated Services are services that originate from the SET. For these services the SUPL Agent resides within the SET.
SET User	The user of a SET.
SIP/IP Core	A network of servers such as proxies and/or registrars that support a variety of SIP based services.
SUPL Agent	A Software and/or hardware entity accessing the SUPL enabler in order to obtain location information.
SUPL Session	Session established between the SET and the SLP using ULP protocol.
SUPL Enabled Terminal (SET)	A logical entity in a device that is capable of communicating with a SUPL Network. Examples of this could be a UE in UMTS, a MS in GSM or IS-95, or a PC over an IP-based transport.
SUPL Location Center (SLC)	Coordinates the operations of SUPL in the network and interacts with the SET over User Plane bearer.
SUPL Location Platform (SLP)	The entity responsible for Location Service Management and Position Determination. The SLP contains the SLC and SPC Functions.
SUPL Network	Access network which facilitates the Location determination functionality and provides the SUPL bearer
SUPL Network Initiated Services	SUPL Network Initiated Services are services, which originate from within the SUPL Network as opposed to the SET. For these services the SUPL Agent resides in the Network.

SUPL Position Calculation	The position calculation function performs the function of calculating the position of a SET. Various positioning calculation modes may be supported by a SUPL service
SUPL Positioning Center (SPC)	Entity in the SUPL Network responsible for all messages and procedures required for position calculation and for the delivery of assistance data.
SUPL Provider	<p>Location information is sensitive personal information and requires specific care with privacy and security. In the case of a Mobile Network Operator it is important that whatever policy the Network Operator decides to implement SUPL functionality cannot be breached. Valid scenarios for MNO controlled SUPL would be:</p> <ol style="list-style-type: none"> 1) The network operator is the single SUPL Provider. 2) The network operator and roaming partners are the only SUPL Providers. 3) The network operator out-sources the SUPL functionality and there is a single 3rd party SUPL Provider. 4) The network operator has an open policy on the provision of SUPL functionality and there are multiple 3rd party SUPL Providers. <p>The SUPL Provider may be independent of an MNO.</p>
SUPL Security Function	SUPL Security Function manages the Authentication and Authorization for SUPL Agents and MLS Applications to access SUPL Services. This function also provides confidentiality and data integrity.
SUPL Service Management System	SUPL Service Management is the function of managing locations of SETs. The function stores, extracts, and modifies the location information of a target SET
User Plane	The User Plane, with its layered structure, provides for user information flow transfer, along with associated controls (e.g., flow control, and recovery from errors, etc).

3.3 Abbreviations

AD	Architecture Document
AFLT	Advanced Forward Link Trilateration
A-GANSS	Assisted Galileo and Additional Navigation Satellite Systems
A-GNSS	Assisted Global Navigation Satellite System
A-GPS	Assisted GPS
API	Application Programming Interface
D-SLP	Discovered SLP
EOTD	Enhanced Observed Time Difference
E-SLP	Emergency SLP
FQDN	Fully Qualified Domain Name
GNSS	Global Navigation Satellite System
GPS	Global Positioning System
GSS	Generic SUPL Session
ILP	Internal Location Protocol
H-SLC	Home SLC
H-SLP	Home SLP
H-SPC	Home SPC
HTTP	Hypertext Transfer Protocol
HTTPS	HTTP Secure

IETF	Internet Engineering Task Force
IMSI	International Mobile Subscriber Identity
IP	Internet Protocol
LCS	Location Services
LOCSIP	Location in SIP/IP core
LPP	LTE Positioning Protocol
LPPe	OMA LPP Extensions
LTE	Long Term Evolution
MC	Message Center
MLP	Mobile Location Protocol
MLS	Mobile Location Services
MNO	Mobile Network Operator
OMA	Open Mobile Alliance
OTDOA	Observed Time Difference of Arrival
PAP	Push Access Protocol
PC	Personal Computer
PLMN	Public Land Mobile Network
POTAP	WAP Push Over The Air Protocol
PPG	Push Proxy Gateway
PSK-TLS	Pre-Shared Key Ciphersuites for Transport Layer Security
QoP	Quality of Position
RD	Requirement Document
RLP	Roaming Location Protocol
RRC	Radio Resource Control
RRLP	Radio Resource LCS Protocol
R-SLP	Requesting SLP
SADF	SUPL Assistance Delivery Function
SCF	SUPL Charging Function
SET	SUPL Enabled Terminal
SIF	SUPL Initiation Function
SIP	Session Initiation Protocol
SLC	SUPL Location Center
SLIA	Standard Location Immediate Answer
SLIR	Standard Location Immediate Request
SLIRep	Standard Location Immediate Report
SLP	SUPL Location Platform
SMLC	Serving Mobile Location Center
SMPP	Short Message Peer to peer Protocol
SMS	Short Message Service
SMSC	Short Message Service Center

SPC	SUPL Positioning Center
SPCF	SUPL Position Calculation Function
SPF	SUPL Privacy Function
SRLIA	Standard Roaming Location Immediate Answer
SRLIR	Standard Roaming Location Immediate Request
SRN	Short Range Node
SRRF	SUPL Reference Retrieval Function
SRSF	SUPL Roaming Support Function
SSF	SUPL Security Function
SSMF	SUPL Service Management Function
SSPF	SUPL SET Provisioning Function
SSRLIA	Standard SUPL Roaming Location Immediate Answer
SSRLIR	Standard SUPL Roaming Location Immediate Request
SUPL	Secure User Plane Location
TD-SCDMA	Time Division-Synchronous Code Division Multiple Access
TLS	Transport Layer Security
UDP	User Datagram Protocol
UE	User Equipment
UICC	Universal Integrated Circuit Card
UMB	Ultra Mobile Broadband
URL	Uniform Resource Locator
V-SLC	Visited SLC
V-SPC	Visited SPC
V-SLP	Visited SLP
WAP	Wireless Application Protocol
WCDMA	Wideband Code Division Multiple Access

4. Introduction

(Informative)

Secure User Plane Location (SUPL) is an Enabler which enables the transfer of assistance and positioning data over an IP User Plane bearer for Network and SUPL Enabled Terminal (SET) based positioning of a SET. SUPL defines the reference point between the SUPL Location Platform (SLP) and the SET (Lup) and between the SUPL Location Center (SLC) and the SUPL Positioning Center (SPC) (Lp). SUPL also defines functions for security (e.g., authentication, authorization), charging, roaming and privacy. SUPL utilizes existing standards where available and possible. SUPL is designed to be extensible to support future positioning technologies as needed.

SUPL services may be invoked by network resident applications using MLP, LOCSIP or other protocols. For SET resident applications, no open interfaces or APIs are specified. To support roaming, SUPL may use [OMA RLP 1.0] or [OMA RLP 1.1].

4.1 Version 1.0

Supported Bearers:

- GSM/GPRS/EDGE
- WCDMA/TD-SCDMA
- CDMA/CDMA2000

Supported modes of operation for selected deployments:

- Proxy flows for GSM/WCDMA/TD-SCDMA deployments;
- Proxy flows for CDMA/CDMA2000 deployments;[3GPP2 HRPD]
- Non-proxy flows for CDMA/CDMA2000 deployments.

Supported Positioning Protocols:

- RRLP
- RRC
- TIA-801

Supported Positioning methods:

- A-GPS (SET-Based, SET-Assisted)
- Autonomous GPS
- E-OTD on GSM
- OTDOA on WCDMA
- AFLT on CDMA/CDMA2000
- Enhanced Cell/Sector ID (for supported bearers)

Supported SUPL services:

- Network Initiated Immediate Fix
- SET Initiated Immediate Fix

Supported roaming models:

- Roaming with H-SLP

- Roaming with V-SLP

Security features:

- Alternative Client Authentication (ACA)
- GBA on 3GPP networks
- TLS-PSK on 3GPP2 networks

4.2 Version 2.0

Additional¹ bearers supported:

- LTE
- HRPD
- I-WLAN
- WiMAX and I-WiMAX

Additional Positioning Protocols supported:

- LPP

Additional Positioning Methods supported:

- A-GANSS
- Autonomous GANSS
- OTDOA over LTE

Additional SUPL services supported:

- Triggered positioning procedures, both periodic and area event;
- Emergency positioning procedures;
- Positioning procedures for delivery to third party and retrieval of location of another SET.

Additional security features:

- GBA supported on 3GPP2 networks
- SEK used on WiMAX networks
- SUPL INIT protection

Other:

- Llp (reference point between SLC and SPC)
- Internal Location Protocol (ILP) used on Llp

¹ Additional to SUPL 1.0

4.3 Version 3.0

Additional² bearers supported:

- Fixed broadband (e.g., cable, DSL, etc.)
- WLAN³

Positioning protocols supported:

- LPP and TIA-801 (RRLP and RRC are no longer supported)
- LPPe

Additional positioning methods supported⁴:

- SET Based Enhanced Cell/Sector ID
- SET Based OTDOA
- High Accuracy A-GNSS
- SET Assisted and SET Based SRN
- Sensors

Supported modes of operation:

- Proxy mode only (non-proxy no longer supported in SUPL 3.0)

Additional SUPL services supported:

- GSS

Roaming models supported:

- Only roaming with H-SLP supported (roaming with V-SLP is no longer supported)

Other:

- Support of Discovered SLP (D-SLP)
- Bearer agnostic ULP and ILP
- Positioning Technology agnostic ULP and ILP

² Additional to SUPL 2.0

³ SUPL 2.0 only supported I-WLAN

⁴ Supported positioning methods are whatever is supported in LPP/LPPe/TIA-801

5. Architectural Model

Secure User Plane Location (SUPL) is an Enabler that utilizes existing standards where available and possible, to transfer assistance data and positioning data over a User Plane bearer, such as IP, to aid network and SET based positioning technologies in the calculation of a SET's position. SUPL includes but is not limited to the definition of a Location User Plane (Lup) Reference Point and corresponding interface between the SUPL Network and SET, security functions (e.g., authentication, authorization), charging functions, roaming functions, and privacy functions.

SUPL is used by MLS Applications via a SUPL Agent to determine the position of a SET. SUPL itself does not specify an API for direct use by MLS Applications.

SUPL can get broadcast services through an abstract functional interface to broadcast system. The interface is dependent on specific broadcasting mechanism which is FFS.

5.1 Dependencies

The SUPL architecture is dependent on the following OMA enablers:

- OMA Mobile Location Service, Version 1.2 (see [OMA MLP 3.3] and [OMA RLP 1.1])
- OMA Push (see [WAP PUSH], [WAP POTAP], [WAP PAP], [SIP PUSH])
- OMA LPP Extensions, Version 1.0 (see [OMA LPPe])
- OMA LOCSIP, Version 1.0 (see [OMA LOCSIP])

The SUPL architecture is also dependent on the following specifications:

- [3GPP LPP]
- [3GPP2 C.S0022-A]
- [3GPP2 C.S0022-0]
- [3GPP2 C.S0022-B]

5.2 Architectural Diagram

This section identifies the SUPL Network architecture model, comprised of the User Plane location services related network entities and associated Reference Points.

A network entity (i.e., system and subsystem) represents a group of functions, and not necessarily a physical device. The physical realization is an implementation decision: a manufacturer may choose any physical implementation of network entities, either individually or in combination, as long as the implementation meets the functional requirements.

A Reference Point is a conceptual demarcation of two groups of functions. It is not necessarily a physical interface. A Reference Point only becomes one or several physical interfaces when the network entities on each of its sides are contained in different physical devices. One or more protocols may be defined for the instantiation of an interface. As the Lup Reference Point is instantiated by one interface, we use both terms in this document. The corresponding protocol is defined in the detailed technical specification [OMA ULP].

In generic environments, the required SUPL components are the SET and the network component SLP containing the SLC and SPC systems. A SUPL Agent may reside within the device and/or within the network. The SET communicates with the SLP over the Lup interface. A SUPL Agent used by a network-based application communicates with the SLP over the L1/Le Reference Point via MLP, LOCSIP, or another protocol. In environments where SLC and SPC are deployed as separate entities, SLC and SPC communicate with each other over the Llp interface. In environments where the SLC and the SPC are deployed as a single entity, the Llp interface does not apply.

In MNO environments, several entities and their interfaces may also be needed as illustrated in the figure in this section.

The detailed functions and definitions of the components defined in this figure are explained in Sections 5.2.2 and 5.3, in Appendices B and C, and in the SUPL TS [OMA ULP].

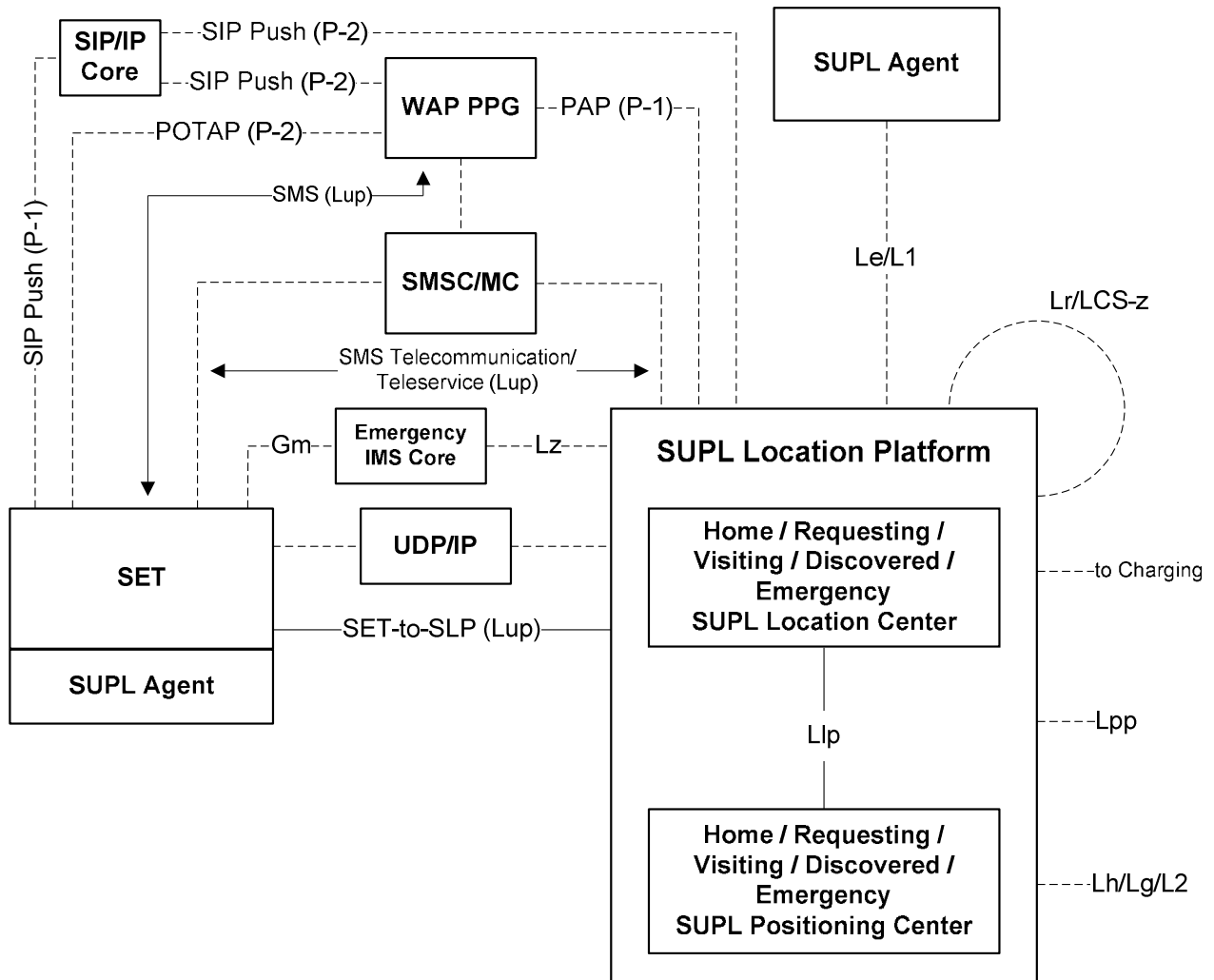

Figure 1: SUPL Architecture

5.2.1 Communication Mechanisms and Interfaces Covered by Lup

The communication mechanisms for conveying location request notification from the SLP to the SET include OMA Push, SMS, UDP/IP and SIP Push. The protocols involved in OMA Push are PAP (Push Access Protocol) for conveying location request notification from the SLP to the PPG (Push Proxy Gateway), and POTAP (Push Over-The-Air Protocol) and SIP Push for conveying such notification from the PPG to the SET. SMS delivery of notification is another option, and can be initiated either by SMS Trigger from the SLP, or by WAP notification. Protocol interfaces for SMS delivery are not specified in the diagram, since the interface between SLP and SMSC/MC is proprietary (e.g., SMPP) and is not defined by 3GPP/3GPP2. The communication path from SMSC/MC to the SET is outside the scope of this document.

In proxy-mode the SUPL application message exchange for service management and positioning determination occurs between the SLP and the SET⁵.

⁵ Non-proxy mode is no longer supported in SUPL 3.0.

5.2.1.1 IMS Emergency Location Services

For IMS emergency location services, the SUPL location request notification may be conveyed from the E-SLP to the SET via the Emergency IMS Core using SIP Push [SIP PUSH]. The Emergency IMS Core correlates the location request notification with the IMS emergency call and delivers the notification to the SET.

5.2.2 SUPL System and Subsystem Descriptions

5.2.2.1 SUPL Location Platform (SLP)

5.2.2.1.1 SLP Role

For any SET, a SLP can perform the role of the home SLP (H-SLP), visited SLP (V-SLP), Discovered SLP (D-SLP) or emergency SLP (E-SLP). A particular SLP may perform one or more of these roles for multiple SETs.

The H-SLP for a particular SET contains the subscription, authentication and privacy related data for the SET and would generally be associated with or be part of the SET's home PLMN.

The E-SLP for a particular SET is an SLP associated with or contained within the PLMN serving the SET that is employed by the serving PLMN to perform positioning in association with an emergency services call initiated by the SET. The E-SLP may be the H-SLP if the SET is not roaming. If the SET is roaming and the E-SLP is not the H-SLP or if the SET is not roaming and the E-SLP is physically or logically separate to the H-SLP, SUPL positioning may occur without interaction with the H-SLP. An E-SLP may also be discovered (see description of D-SLP below).

The V-SLP for a particular SET would be an SLP chosen by the H-SLP or E-SLP to assist positioning. In the case of an H-SLP, the SET would be roaming outside the coverage area of the H-SLP. In the case of an E-SLP, the SET would have initiated an emergency services call outside the coverage area of the E-SLP. Note that the coverage area of an SLP need not be the same as the coverage area of any PLMN with which the SLP is associated.

It should be noted that SUPL roaming will not occur and a V-SLP will not be needed for positioning associated with emergency services calls if calls can only be placed within the service area of an E-SLP.

The D-SLP is an SLP that has been discovered by the SET. The discovery function is described in section 5.3.1.9. The availability and use of a D-SLP is optional.

5.2.2.1.2 SLP Architecture

The SLP consists of an SLC and SPC. The SLC and SPC may be integrated into a single system. The Lup interface is used between the SLP and the SET. The Lup interface is used to deliver messages for Location Management and Positioning Determination.

It may also be possible to separate the SLC and SPC functionality into separate systems within the SLP.

SET and SLP communicate using proxy mode. In proxy mode, the SPC system will not have direct communication with the SET. In this environment the SLC system will act as a proxy between the SET and the SPC.

The Lup interface is used between the SLP and SET. The Lup carries two types of messaging:

- Messaging destined to the SLC system within the SLP – Lup Location Management Messages
- Messaging destined to the SPC system within the SLP – Lup Positioning Determination Messages

5.2.2.2 SUPL Location Center (SLC)

The SLC system coordinates the operations of SUPL in the network and performs the following functions as it interacts with the SET over User Plane bearer:

- SUPL Privacy Function (SPF)

- SUPL Initiation Function (SIF)
- SUPL Security Function (SSF)
- SUPL Roaming Support Function (SRSF)
- SUPL Charging Function (SCF)
- SUPL Service Management Function (SSMF)
- SUPL Triggering Function (STF)
- SUPL Positioning Calculation Function (SPCF)
 - The SLC may perform the translation of a location identifier to a geographic location expressed in latitude and longitude data. This location may meet the requested QoP of the SUPL Agent. In MNO environments this is often referred to as Cell-ID location.
- SUPL SLP Discovery Function (SSDF)

5.2.2.3 SUPL Positioning Center (SPC)

The SPC supports the following functions:

- SUPL Assistance Delivery Function (SADF)
- SUPL Reference Retrieval Function (SRRF)
- SUPL Positioning Calculation Function (SPCF)

5.2.2.4 SUPL Enabled Terminal (SET)

The SET supports the procedures defined in SUPL as it interacts with the network over the User Plane bearer. The SET may support one or more of the following functions depending on its capabilities and the SUPL Provider’s business rules:

- SUPL Privacy Function (SPF)
- SUPL Security Function (SSF)
- SUPL SET Provisioning Function (SSPF)
- SUPL Initiation Function (SIF)
- SUPL Triggering Function (STF)

The SET supports SET-based and/or SET-assisted positioning calculation. The SET may support the following functions:

- SUPL Positioning Calculation Function (SPCF)
- SUPL Assistance Delivery Function (SADF)
- SUPL SLP Discovery Function (SSDF)

There is overlap between functionalities of SLC/SPC and SET.

5.2.2.5 Allocation of SUPL Functions to SUPL Subsystems

Table 1 shows the allocation of SUPL functional entities to elements of the SUPL System.

	SLC	SPC	SET
SUPL Location Services Functional Group			
SUPL Privacy Function (SPF)	○		○
SUPL Initiation Function (SIF)	○		○
SUPL Security Function (SSF)	○		○
SUPL Roaming Support Functions (SRSF)	○		

SUPL Charging Function (SCF)	○		
SUPL Service Management Function (SSMF)	○		
SUPL SET Provisioning Function (SSPF)			○
SUPL Triggering Function (STF)	○		○
SUPL SLP Discovery Function (SSDF)	○		○
SUPL Positioning Functional Group			
SUPL Assistance Delivery Function (SADF)		○	○
SUPL Reference Retrieval Function (SRRF)		○	
SUPL Positioning Calculation Function (SPCF)	○	○	○
	SLC	SPC	SET

Table 1: Allocation of SUPL Functions to SUPL Subsystems

5.3 Functional Components and Interfaces/reference points definition

5.3.1 SUPL Location Services Functional Group

This section identifies and describes the logical functional entities within the SUPL location services functional group. The purpose of this section is to ensure that all possible functions are identified which are required to enable a SUPL service.

5.3.1.1 SUPL Privacy Function (SPF)

The SPF is the function of ensuring the privacy of a SET User is honored. The following must be considered:

- Adhere to the target SET User privacy setting regardless of SUPL Network Initiated Services or SET Initiated Services
- Adhere to notification and verification settings of the target SET User
- Allow override of the target SET User privacy settings as mandated or allowed by local regulations for positioning for an emergency services call
- Allow for future lawful override regulations that may apply to the target SET User

SUPL may use other enablers to implement parts of the SPF. Alternatively, the SPF may be implemented in the SET.

5.3.1.2 SUPL Initiation Function (SIF)

The SIF provides a mechanism for a SUPL Network to initiate a transaction with a SET. The initiation function is of special importance in enabling SUPL Network Initiated Services.

In case of a SUPL Network Initiated Service the SUPL Network initiates the SUPL transaction by using one of the following methods:

- OMA Push
- SMS directly in an MNO environment
- UDP/IP
- SIP Push [SIP PUSH]

Note: OMA Push is considered to be any delivery method that utilizes the Push Access Protocol (PAP), regardless of whether POTAP or SIP Push is used for the final delivery to the SET.

Depending upon SET capabilities, the applicable SIF method is applied by the SUPL Network (determination of SET capabilities is out of scope of SUPL).

A SET SHALL support the SIF using at least one of POTAP, SIP Push and SMS. A SET that is capable of initiating an emergency services call using an IP bearer⁶ SHALL also support the SIF using UDP/IP or SIP Push.

For GSM/WCDMA/TD-SCDMA deployments, the SIF using OMA Push SHALL be supported by both the SET and the SLP. For CDMA/CDMA2000 deployments, the SIF using MT SMS SHALL be supported by both the SET and the SLP. Support of other transport protocols is optional.

5.3.1.3 SUPL Security Function (SSF)

The SSF enables the SUPL Network to authenticate and authorize the SET and enables the SET to authenticate and authorize the SUPL Network. This is important in safely enabling both SUPL Network Initiated Services and SET Initiated Services.

The SSF also provides confidentiality and data integrity. Refer to Section 6 in the SUPL 3.0 ULP TS for details of the SSF implementation.

5.3.1.4 SUPL Roaming Support Function (SRSF)

For positioning not associated with an emergency services call, SUPL roaming occurs when a SET leaves the service area of its H-SLP. For positioning associated with an emergency services call, SUPL roaming occurs when the SET is not within the service area of the E-SLP. The service area of an H-SLP or E-SLP includes the area within which the H-SLP or E-SLP can provide a position estimate for a SET or relevant assistance data to a SET without contacting other SLPs. It should be noted that an H-SLP or E-SLP service area is not necessarily associated with the service area(s) of the underlying wireless network(s).

For roaming, the H-SLP or E-SLP may request the V-SLP to provide an initial position estimate, e.g., based upon Location ID. This mode of roaming is called “Roaming with H-SLP” since the actual positioning determination session is conducted between the H-SLP and the SET⁷.

5.3.1.5 SUPL Charging Function (SCF)

The SCF is responsible for charging activities within the SLP. This includes charging of MLS Application, SUPL Agents and SET Users.

The main task of the SCF is to collect appropriate charging related data and data for accounting between SUPL Providers. Additionally, the SCF may authorize activities in the SLP (e.g., assistance data and location delivery) based on assessment of available charging data. Further details of the SCF are outside the scope of SUPL.

5.3.1.6 SUPL Service Management Function (SSMF)

The SSMF is the function of managing locations of SETs. This function stores, extracts, and modifies the location information of a target SET. During the execution of this function, the integration with charging, privacy, security, QoS functions SHALL be considered.

⁶ While SET support of SUPL for positioning in association with an emergency services call initiated using an IP bearer is mandated in this specification, a network operator may choose not to employ SUPL – e.g., may use a control plane location solution.

⁷ “Roaming with V-SLP” where the positioning determination session is conducted between the V-SLP and the SET is no longer supported in SUPL 3.0.

5.3.1.7 SUPL SET Provisioning Function (SSPF)

The SSPF is the function that manages the provisioning for the SET. The SET SHALL be provisioned with the address of the Home SLP. The provisioning of the Home SLP address in the SET MAY use OMA enablers to provision the SET.

5.3.1.8 SUPL Triggering Function (STF)

The SUPL Triggering Function is the function of communicating periodic and event based triggers between the SLP and the SET and evaluating when those trigger conditions have been fulfilled.

For Network Initiated Triggered Services, the SLP delivers trigger criteria to the SET. For SET Initiated Triggered Services, the SET sends trigger criteria to the SLP. In some circumstances, the SLP may also return additional trigger criteria to the SET during SET Initiated Triggered Services (e.g., an area id list if the SET has requested an event based trigger with a geographic target area).

It is the responsibility of the SET to determine when these trigger criteria have been met.

For periodic triggers, the criteria may include:

- the number of fixes;
- the interval between fixes;
- a start time for the trigger.

For event based triggers, the criteria may include:

- the type of the area event (Entering, Leaving, Inside or Outside) (see 5.3.1.8.2 for more details);
- a geographic target area list;
- an area id list;
- repeated reporting information which indicates whether the SET can re-use the trigger and for how many times and at what minimum interval (see 5.3.1.8.1 for more details);
- a start and a stop time.

When an area id list but not a geographic target area list is present in an event based trigger, the area id list is used as the target area for the trigger. When a geographic target area list is present but not an area id list, the geographic target area list is taken as the target area. When both a geographic target area list and an area id list are present in an event based trigger, the geographic target area is taken as the actual target area and the area id list is used to help the SET avoid unnecessary positioning attempts (the exact procedure will vary based on the type of trigger and is explained in more detail in [OMA ULP]).

5.3.1.8.1 Repeated reporting and event triggers

When event based triggers are combined with repeated reporting, a minimum interval and a number of reports must be specified. Regardless of the event type (see 5.3.1.8.2 for a detailed description of the different event types), the SLP and the SET shall continue the triggered event session until either:

- the requested number of reports has been returned;
- the stop time, if present, has elapsed;
- a SUPL TRIGGERED STOP or SUPL END has been received to cancel the session.

5.3.1.8.2 Event trigger types

The “Entering” and “Inside” trigger types both mean the SET should report as soon as it detects that it is inside the target area. The difference between these trigger types is in their behavior when combined with repeated reporting. With repeated reporting, the “Entering” trigger will be initially fulfilled the first time the SET detects that it is inside the target area. For the trigger condition to be fulfilled again, the SET has to subsequently detect that it has left the target area and then re-entered.

Whenever the SET sends a report, it must wait for the minimum reporting interval before checking if the trigger condition is fulfilled again.

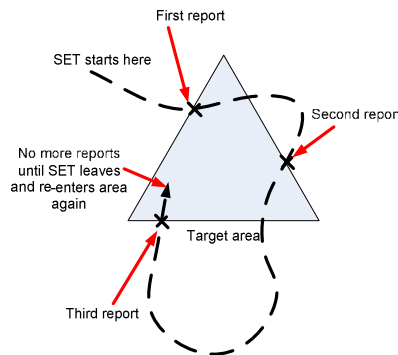

Figure 2: The “Entering” Trigger with Repeated Reporting

The “Inside” trigger, by contrast, when combined with repeated reporting will result in repeated reports for as long as the SET detects that it is inside the area.

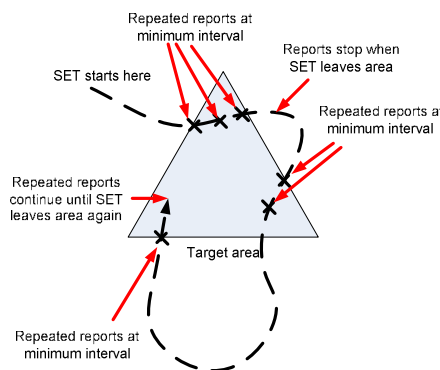

Figure 3: The “Inside” Trigger with Repeated Reporting

Note that for both the “Entering” and “Inside” trigger types, if the SET starts out within the target area when the trigger becomes active (i.e., at the receipt of the trigger criteria if no start time was specified or at the appropriate start time if one was specified), the trigger condition will be fulfilled. There is no requirement for the SET to verify that it was previously outside the area before the first report is sent.

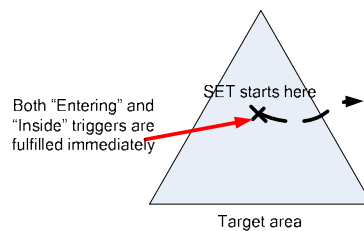

Figure 4: SET Starting Inside Target Area for both “Entering” and “Inside” Triggers

The “Leaving” and “Outside” trigger types behave in a similar manner, but are only fulfilled when the SET is outside the target area. As with the “Entering” and “Inside” trigger types, the “Leaving” and “Outside” triggers have identical behaviors when no repeated reporting is used. They are both fulfilled the first time the SET detects that it is outside the target area.

With repeated reporting, the leaving trigger is fulfilled the first time the SET detects that it is outside the target area, and then subsequently each time the SET detects that it has re-entered the target area and then exited again. Whenever the SET sends a report, it must wait for the minimum reporting interval before checking if the trigger condition is fulfilled again.

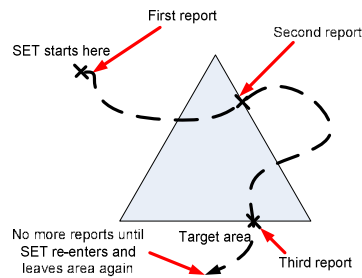

Figure 5: The “Leaving” Trigger with Repeated Reporting

The “Outside” trigger, when combined with repeated reporting, results in repeated reports at the minimum reporting interval for as long as the SET remains outside the target area.

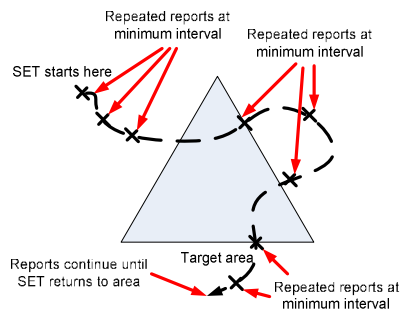

Figure 6: The “Outside” Trigger with Repeated Reporting

5.3.1.9 SLP Discovery Function (SSDF)

The SSDF enables the SET to discover an additional SLP, the D-SLP or E-SLP, as a complement to the H-SLP. The selection of D-SLP or E-SLP can be based on but not limited to conditions as access type, location and service type. SSDF uses a discovery and authorization mechanism in the H-SLP or a discovery mechanism external to SUPL combined with an authorization mechanism in the H-SLP.

5.3.2 SUPL Positioning Functional Group

This section identifies and describes the logical functional entities within the SUPL Positioning Functional Group.

5.3.2.1 SUPL Assistance Delivery Function (SADF)

The SADF selects, generates and delivers available assistance data that is used for the measurement or the calculation of a SET position. The assistance data delivery may be based on a selected subset of GPS or GANSS reference data retrieved from SRRF function, the capability of SET and network, and the approximate position information of the target SET.

Assistance data consist of the elements defined in [3GPP LPP], [OMA LPPe] or [3GPP2 C.S0022-A], [3GPP2 C.S0022-0].

5.3.2.2 SUPL Reference Retrieval Function (SRRF)

The SRRF is the function of retrieving GPS or GANSS reference data from a GPS or GANSS reference network. Reference data is needed to generate assistance data. The interface between this function and GPS or GANSS reference network is outside the scope of this document.

5.3.2.3 SUPL Position Calculation Function (SPCF)

The SPCF selects the positioning protocol and protocol version, and performs the function of calculating the position of a SET. One or more of the following positioning calculation modes may be supported by a SUPL service.

- A-GPS SET assisted
- A-GPS SET based
- A-GANSS SET assisted
- A-GANSS SET based
- Autonomous GPS or Autonomous GANSS
- Enhanced Cell/Sector
- AFLT
- EOTD
- OTDOA
- High Accuracy A-GNSS SET assisted
- High Accuracy A-GNSS SET based
- SRN SET assisted
- SRN SET based
- Sensors

Note: Applicability of a particular positioning calculation mode is subject to the support in relevant 3GPP, 3GPP2 and OMA specifications that SUPL relies on.

The SET may have location URI(s) available and convey them from SET to SLP. The SLP can get SET's location information using the location URI(s), and use the location as an alternative location source for the SET.

5.3.3 SUPL Reference Point Definitions

This section defines the Reference Points identified in the SUPL architecture.

5.3.3.1 Lup Reference Point

The function of the Lup Reference Point is logically separated into Location Service Management and Positioning Determination.

5.3.3.1.1 Lup Location Service Management Messages

This Reference Point is used to enable the SLP to establish a session with the SET.

5.3.3.1.2 Lup Positioning Determination Messages

The Lup Positioning Determination Reference Point is used to transport information between the SET and the SLP for the calculation of position.

5.3.3.2 Llp Reference Point

The Llp reference logically separates the Positioning Control Function and the Positioning Data Function.

5.3.3.2.1 Llp Positioning Control Function Messages

The Positioning Control Function is used in the establishment, maintenance and clearing of sessions between the SLC and the SPC.

5.3.3.2.2 Llp Positioning Data Function Messages

The Positioning Data Function is used to transport the data that is used for position calculations.

5.4 Security Considerations

This section provides a brief high level description of the SUPL Security Function, the details of which are described in [OMA ULP].

5.4.1 Authentication

Mutual authentication SHALL be supported between a SET and an H-SLP. Server authentication SHALL be supported between a SET and an E-SLP, and mutual authentication MAY be supported between a SET and E-SLP. Mutual authentication SHALL be supported between a SET and an D-SLP.

When mutual authentication is performed, the SET SHALL act on behalf of the SET User via a SUPL Agent contained in the SET using the security credentials associated with the SET User, which in turn are provisioned by the SUPL Provider.

5.4.2 Providing the H-SLP Address to the SET

The H-SLP address is made available to the SET by the provisioning of the H-SLP address in the UICC, SET or a default H-SLP address is derived. This address MUST be in the form of a FQDN and SHOULD be securely provisioned by the Home Network of the SET [OMA ULP].

5.4.3 Confidentiality and Data Integrity

TLS 1.1 [TLS] or PSK-TLS [PSK-TLS] SHALL be used to provide Confidentiality and Data Integrity between a SET and an SLP. All SUPL Messages except "SUPL INIT" MUST be delivered within a TLS or PSK-TLS session between a SET and an SLP [OMA ULP].

Appendix A. Change History (Informative)

A.1 Approved Version History

Reference	Date	Description
n/a	n/a	No prior version –or- No previous version within OMA

A.2 Draft/Candidate Version <current version> History

Document Identifier	Date	Sections	Description
Draft Versions OMA-AD-SUPL-V3_0	03 Feb 2009	All	Initial draft AD for V3.0
	11 May 2009	1, 2, 3, 4, 5	<ul style="list-style-type: none"> ▪ Incorporates input to committee:OMA-LOC-2009-0086-CR_SUPL3_0_AD_Section1_Scope ▪ OMA-LOC-2009-0087-CR_SUPL3_0_AD_Section2_References ▪ OMA-LOC-2009-0088-CR_SUPL3_0_AD_Section3_Terminology_and_Conventions ▪ OMA-LOC-2009-0089-CR_SUPL3_0_AD_Section4_Introduction ▪ OMA-LOC-2009-0090-CR_SUPL3_0_AD_Section5_Architectural_Model
	10 Feb 2010	4, 4.1 Appendix B	Incorporated input to committee: <ul style="list-style-type: none"> ▪ OMA-LOC-2010-0015R01-CR_SUPL3_0_AD_add_Version3_0_introduction ▪ OMA-LOC-2010-0026R02-CR_SUPL3_0_AD_new_chapter_for_Lup
	26 Mar 2010	5.3.2.3	Incorporated input to committee: <ul style="list-style-type: none"> ▪ OMA-LOC-2010-0029R04-CR-SUPL3_0_AD_for_URI_Convergyance
	27 Apr 2010	5, 5.1	Incorporated input to committee: <ul style="list-style-type: none"> ▪ OMA-LOC-2010-0075R02-CR_SUPL3_0_AD_Architecture_Change_for_Broadcast
	03 Jan 2011	2.2, 3.2, 5.2.2 5.3.3	Incorporated input to committee: <ul style="list-style-type: none"> ▪ OMA-LOC-2010-0298-CR_SUPL_30_AD_Arch_Model ▪ OMA-LOC-2010-0299-CR_SUPL_30_AD_Message_Listing
	15 Feb 2011	1, 2.1, 3.1, 3.2, 3.3, 4, 5, 5.1, 5.2, 5.2.2.1.1, 5.2.2.3, 5.2.2.5, 5.3.1, 5.3.1.3, 5.3.1.4, 5.3.1.8, 5.3.1.8.2, 5.3.2.1, 5.3.3.1.1, 5.3.3.1.2, 5.4, B.2, B.3, B.4, B.5, B.7, C.2	Incorporated the following approved CRs: <ul style="list-style-type: none"> ▪ OMA-LOC-2010-0300R01-CR_SUPL_3_0_AD_LOCSIP_Support ▪ OMA-LOC-2011-0016R01-CR_SUPL_3_0_ADRR_Comment_A005 ▪ OMA-LOC-2011-0020-CR_SUPL3_0_AD_A008_009_ContextModel ▪ OMA-LOC-2011-0021-CR_SUPL3_0_AD_A010_SUPL_Agent ▪ OMA-LOC-2011-0023R02-CR_SUPL3_0_AD_A012_A013_Discovery ▪ OMA-LOC-2011-0024-CR_SUPL3_0_AD_A014_DSLLP_Security ▪ OMA-LOC-2011-0037-CR_SUPL_V3.0_ADRR_Comment_A007 Incorporated the SUPL3.0 AD changes in: <ul style="list-style-type: none"> ▪ OMA-LOC-2011-0010R01-ADRR_SUPL_V3_0_20110126_D
Candidate Versions OMA-AD-SUPL-V3_0	08 Mar 2011	All	TP approved via R&A: OMA-TP-2011-0080-INP_SUPL_3.0_AD_for_Candidate_approval

Appendix B. Lup Reference Point Flows (Informative)

The flows shown in this appendix show the Lup interface message exchange. The flows can be divided into two categories: Network Initiated and SET Initiated.

A Network Initiated flow occurs when the positioning is requested by a SUPL Agent in the network.

A SET Initiated flow occurs when the positioning is requested by the SET.

The flows presented in this appendix are intended to illustrate the basic concept and are not meant to provide a comprehensive description of the flows. Also, the flow scenarios presented here are not exhaustive but only represent a selected set of flows used to illustrate the basic flow concept. Refer to [OMA ULP] for a complete list of flows with detailed descriptions.

B.1 SET Initiated flows – Immediate Service – Non Roaming

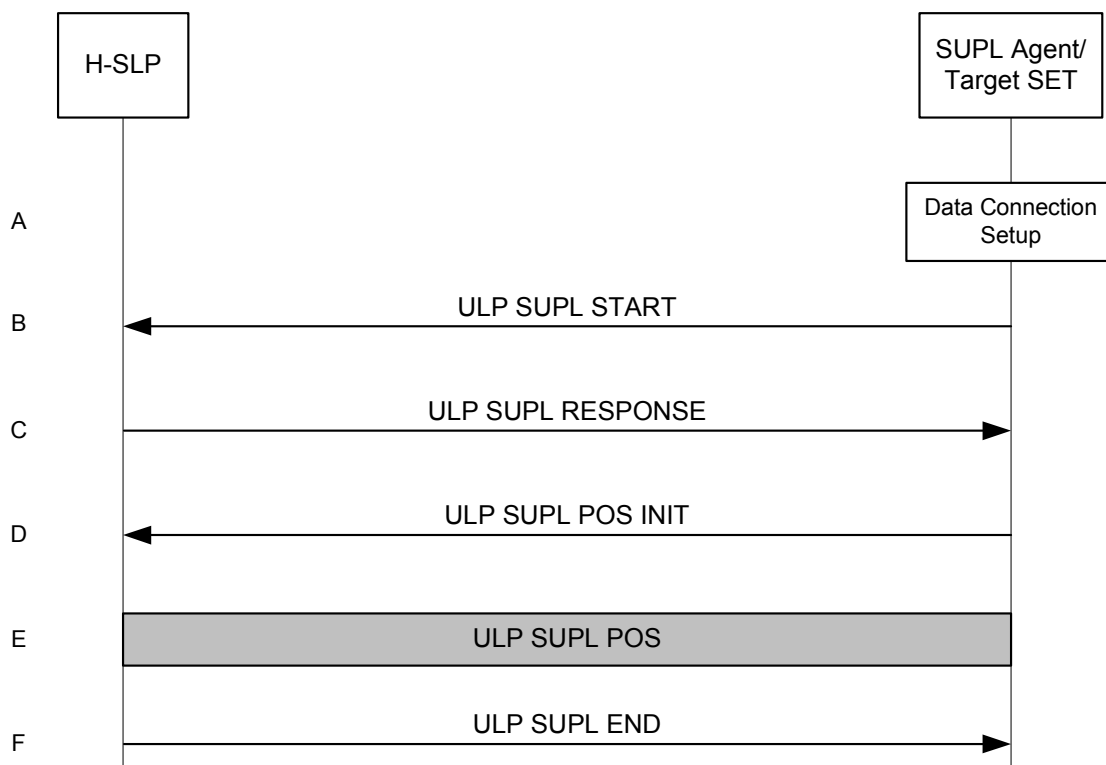

Figure 7: SET-Initiated Non-Roaming

- A. The SUPL Agent on the SET receives a request for position from an application running on the SET. The SET establishes secure connection to the H-SLP.
- B. The SET sends a ULP SUPL START message to start a SUPL Session with the H-SLP.
- C. The H-SLP responds with a ULP SUPL RESPONSE message to the SET.
- D. The SET then sends a ULP SUPL POS INIT message to start a positioning session with the H-SLP. The ULP SUPL POS INIT message may contain positioning protocol payload (LPP or TIA-801).
- E. The H-SLP then determines the positioning method and exchanges several successive ULP SUPL POS messages, containing positioning protocol payload (LPP or TIA-801), as needed to determine the position

- F. When the position calculation is complete the H-SLP sends the ULP SUPL END message to the SET informing it that the SUPL Session is finished. The SET then releases the secure connection to the H-SLP.

B.2 Network Initiated flows – Immediate Service – Non Roaming

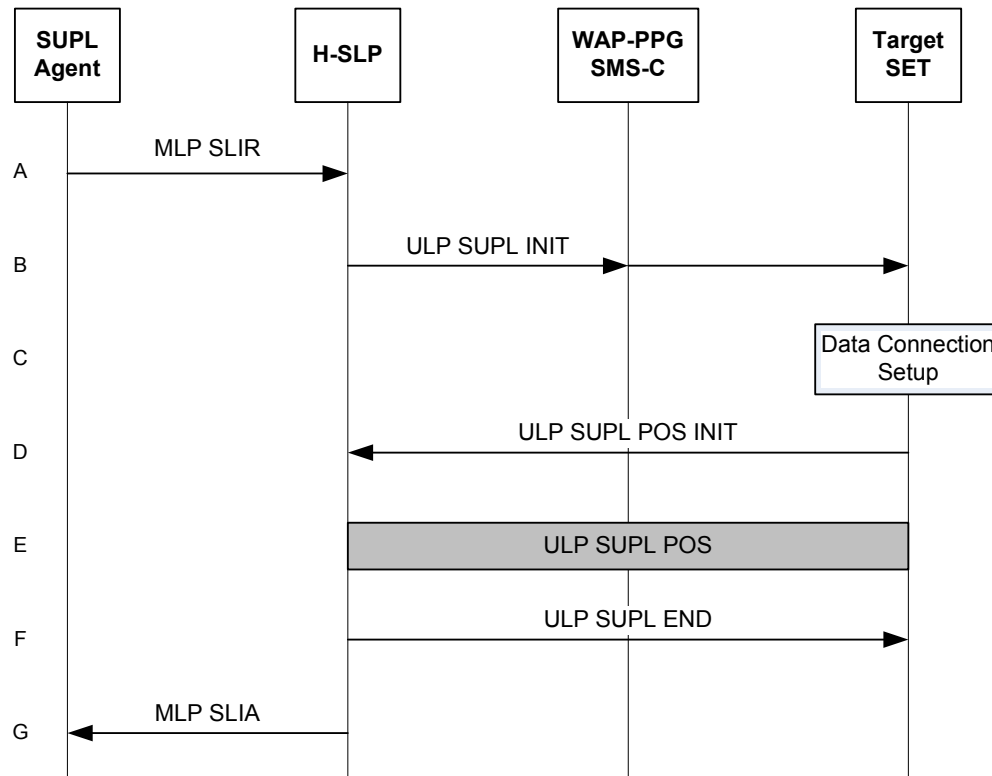

Figure 8: Network Initiated Non-Roaming

- A. The SUPL Agent issues an MLP SLIR message to the H-SLP.

Note: Whereas this and other flows in this Appendix illustrate the use of MLP messages for the Le/L1 Reference Point between the SUPL Agent and the H-SLP, other protocols can be used for these interactions. For example, Appendix D in [OMA ULP] illustrates various flows based on the use of OMA LOCSIP 1.0 [OMA LOCSIP] for the Le/L1 Reference Point.

- B. The H-SLP initiates the SUPL Session with the SET by sending a ULP SUPL INIT message. The message contains the requested positioning method.

Note: the WAP-PPG/SMSC network element is only involved if OMA Push or MT SMS is used for delivering the ULP SUPL INIT message to the SET.

- C. When the ULP SUPL INIT message is received by the SET it establishes a secure connection to the H-SLP.
- D. The SET then sends a ULP SUPL POS INIT message to start a positioning session with the H-SLP. The message contains the SET capabilities. The ULP SUPL POS INIT message may also contain positioning protocol payload (LPP or TIA-801).
- E. The H-SLP then determines the positioning method and exchanges several successive ULP SUPL POS messages, contain positioning protocol payload (LPP or TIA-801), as needed to determine the position.
- F. When the position calculation is complete, the H-SLP sends the ULP SUPL END message to the SET informing it that the SUPL Session is finished. The SET then releases the secure connection to the H-SLP.

G. The H-SLP sends the position estimate back to the SUPL Agent in an MLP SLIA message.

B.3 Network Initiated Triggered Services: Periodic Triggers – Non Roaming

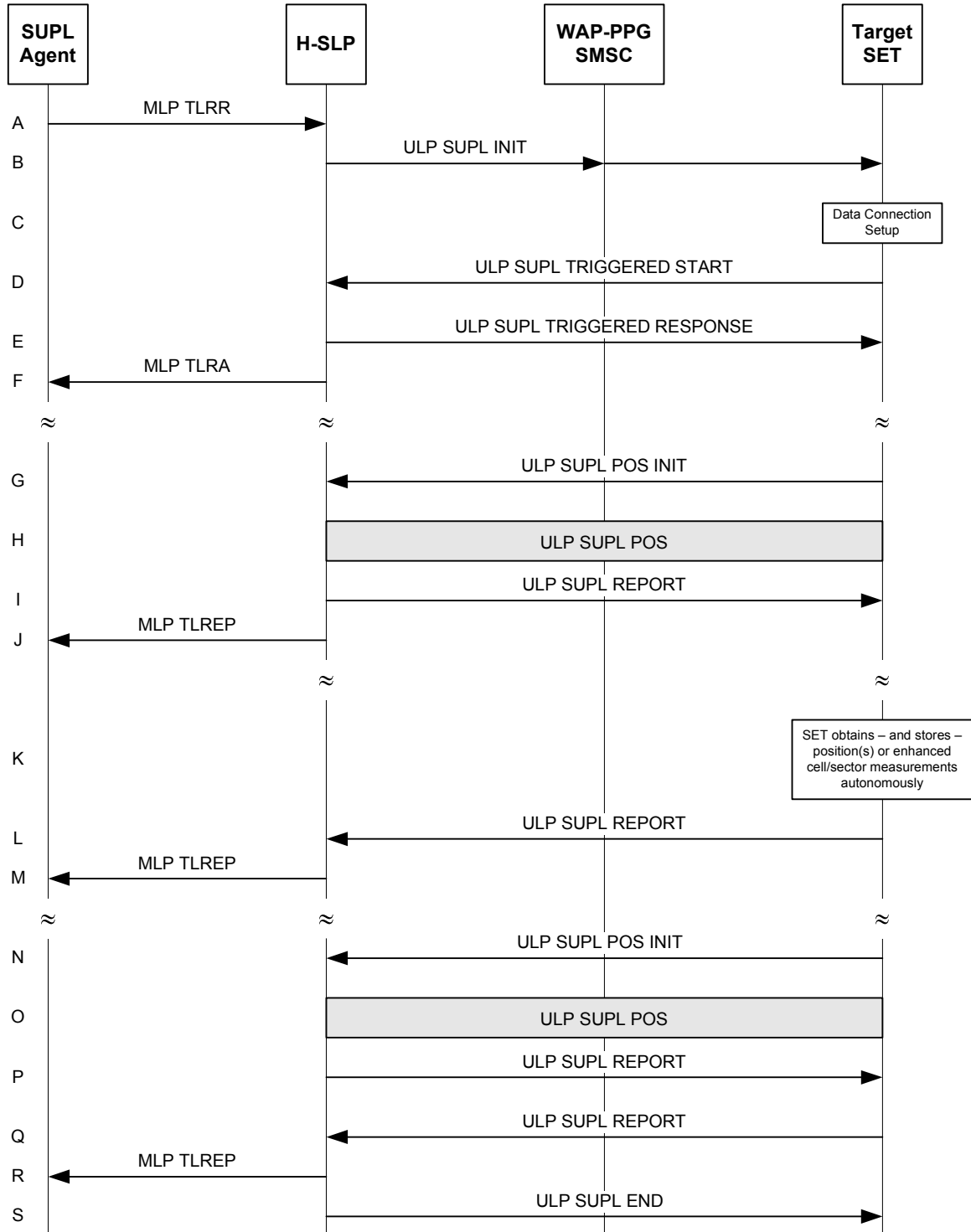

Figure 9: Network Initiated Periodic Triggered Service Non-Roaming

A. The SUPL Agent issues an MLP TLRR to the H-SLP.

- B. The H-SLP initiates the periodic trigger session with the SET using the ULP SUPL INIT message. The message contains the intended positioning method.

Note: the WAP-PPG/SMSC network element is only involved if OMA Push or MT SMS is used for delivering the ULP SUPL INIT message to the SET.

- C. When the ULP SUPL INIT message is received by the SET it will establish a secure connection to the H-SLP.
- D. The SET then sends a ULP SUPL TRIGGERED START message to start a periodic triggered session with the H-SLP.
- E. The H-SLP selects the positioning method to be used for the periodic triggered session and responds with a ULP SUPL TRIGGERED RESPONSE message. This message contains the positioning method and periodic trigger parameters.
- F. The H-SLP informs the SUPL Agent in an MLP TLRA message that the triggered location response request has been accepted. The SET and the H-SLP may release the secure IP connection.
- G. When the periodic trigger in the SET indicates that the first position fix has to be performed, the SET sends a ULP SUPL POS INIT message to start a positioning session with the H-SLP. Note: if there is no secure connection between the SET and the H-SLP, the SET establishes a secure connection before sending the ULP SUPL POS INIT message to the H-SLP. The ULP SUPL POS INIT message may contain positioning protocol payload (LPP or TIA-801).
- H. The SET and the H-SLP MAY exchange several successive ULP SUPL POS messages containing positioning protocol payload (LPP or TIA-801) as needed to determine the position.
- I. If the reporting mode is batch reporting and SET Assisted mode is used, the position calculated by the H-SLP is reported back to the SET for storage in an ULP SUPL REPORT message.
- J. When the position calculation is complete, the H-SLP sends a MLP TLREP message to the SUPL Agent. This message contains the positioning result. The SET and the H-SLP may release the secure IP connection.
- K. If the SET cannot communicate with the H-SLP (e.g. no radio coverage available) and if batch reporting or quasi-real time reporting is used, the SET performs either SET Based position fixes or enhanced cell/sector measurements.
- L. The SET sends any stored position estimates in an unsolicited ULP SUPL REPORT message to the H-SLP. Where applicable, stored enhanced cell/sector measurements are sent within positioning payload messages (LPP or TIA-801). Note: if there is no secure connection between the SET and the H-SLP, the SET establishes a secure connection before sending the ULP SUPL REPORT message to the H-SLP.
- M. If enhanced cell/sector measurements are received in step L, the H-SLP calculates corresponding position estimates. The H-SLP forwards the reported and/or calculated position estimate(s) to the SUPL Agent in an MLP TLREP message.

Steps N-to-P are a repeat of steps G-to-I. Step K might be repeated if necessary.

- Q. The SET sends any stored position estimates in an unsolicited ULP SUPL REPORT message to the H-SLP. Where applicable, stored enhanced cell/sector measurements are sent within positioning payload messages (LPP or TIA-801). Note: if there is no secure connection between the SET and the H-SLP, the SET establishes a secure connection before sending the ULP SUPL REPORT message to the H-SLP.
- R. If enhanced cell/sector measurements are received in step Q, the H-SLP calculates corresponding position estimates. The H-SLP forwards the reported and/or calculated position estimate(s) to the SUPL Agent in an MLP TLREP message.
- S. After the last position result has been reported to the SUPL Agent in step R, the H-SLP ends the periodic triggered session by sending a SUPL END message to the SET. The SET then releases the secure connection to the H-SLP.

B.4 Network Initiated Triggered Services: Area Event Triggers – Non Roaming

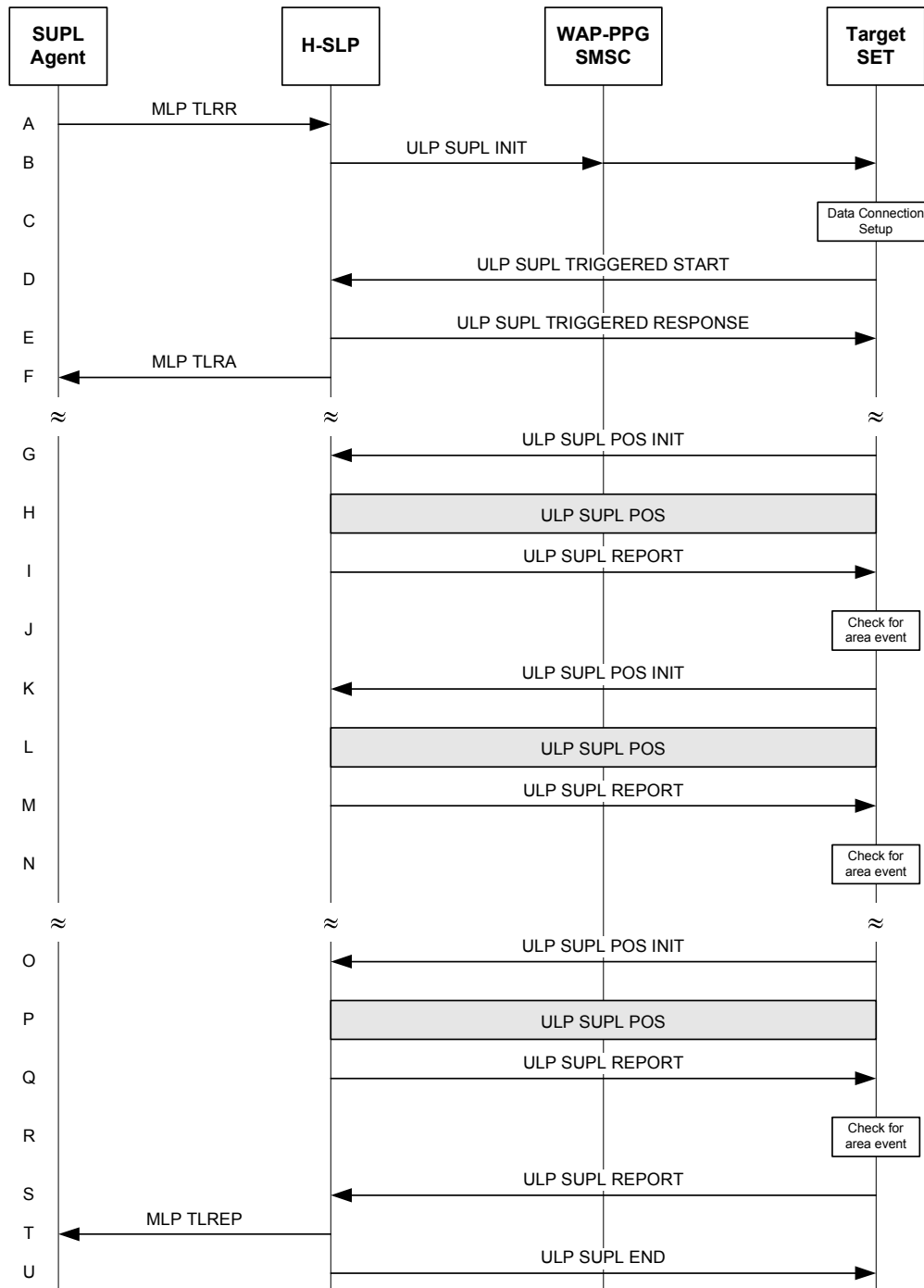

Figure 10: Network Initiated Area Event Triggered Service Non-Roaming

- A. SUPL Agent issues an MLP TLRR to the H-SLP.
- B. The H-SLP initiates the area event trigger session with the SET using the ULP SUPL INIT message. The message contains the intended positioning method.

Note: the WAP-PPG/SMSC network element is only involved if OMA Push or MT SMS is used for delivering the ULP SUPL INIT message to the SET.

- C. When the ULP SUPL INIT is received by the SET it will establish a secure connection to the H-SLP.
- D. The SET then sends a ULP SUPL TRIGGERED START message to start an area event triggered session with the H-SLP.
- E. The H-SLP selects a positioning method to be used for the area event triggered session and responds with a ULP SUPL TRIGGERED RESPONSE message. This message contains the positioning method and area event trigger parameters. The SUPL TRIGGERED RESPONSE message may contain the area ids of the specified area for the area event triggered session
- F. The H-SLP informs the SUPL Agent in an MLP TLRA message that the triggered location response request has been accepted. The SET and the H-SLP may release the secure IP connection.
- G. When the area event trigger mechanism in the SET or the comparison of the current area id to the downloaded area ids (if any) indicates that a position fix is to be executed, the SET sends a SUPL POS INIT message to start a positioning session with the H-SLP. Note: if there is no secure connection between the SET and the H-SLP, the SET establishes a secure connection before the sending the SUPL POS INIT message to the H-SLP. The ULP SUPL POS INIT message may contain positioning protocol payload (LPP or TIA-801).
- H. The SET and the H-SLP MAY exchange several successive ULP SUPL POS messages containing positioning protocol payload (LPP or TIA-801) as needed to determine the position.
- I. When the positioning procedure is complete the H-SLP sends a ULP SUPL REPORT message to the SET. This message may contain the positioning result. The SET and the H-SLP may release the secure IP connection.
- J. The SET compares the calculated position estimate with the event area to check if the event trigger condition has been met. In this case no area event is triggered.

Whenever the area event trigger mechanism in the SET indicates that a new position fix has to be performed, steps G-to-J are repeated (e.g., steps K-to-N are a repeat of steps G-to-J).

- R. The SET compares the calculated position with the event area to check if the event trigger condition has been met. In this case the area event is triggered.
- S. If there is no secure connection between the SET and the H-SLP, the SET establishes a secure connection with the H-SLP. The SET sends a ULP SUPL REPORT message to the H-SLP. This message contains the position estimate.
- T. The H-SLP sends a MLP TLREP message to the SUPL Agent. This message contains the position estimate.
- U. The H-SLP ends the area event triggered session by sending a ULP SUPL END message to the SET. The SET then releases the secure IP connection.

B.5 Network Initiated flows – Immediate Service – Roaming

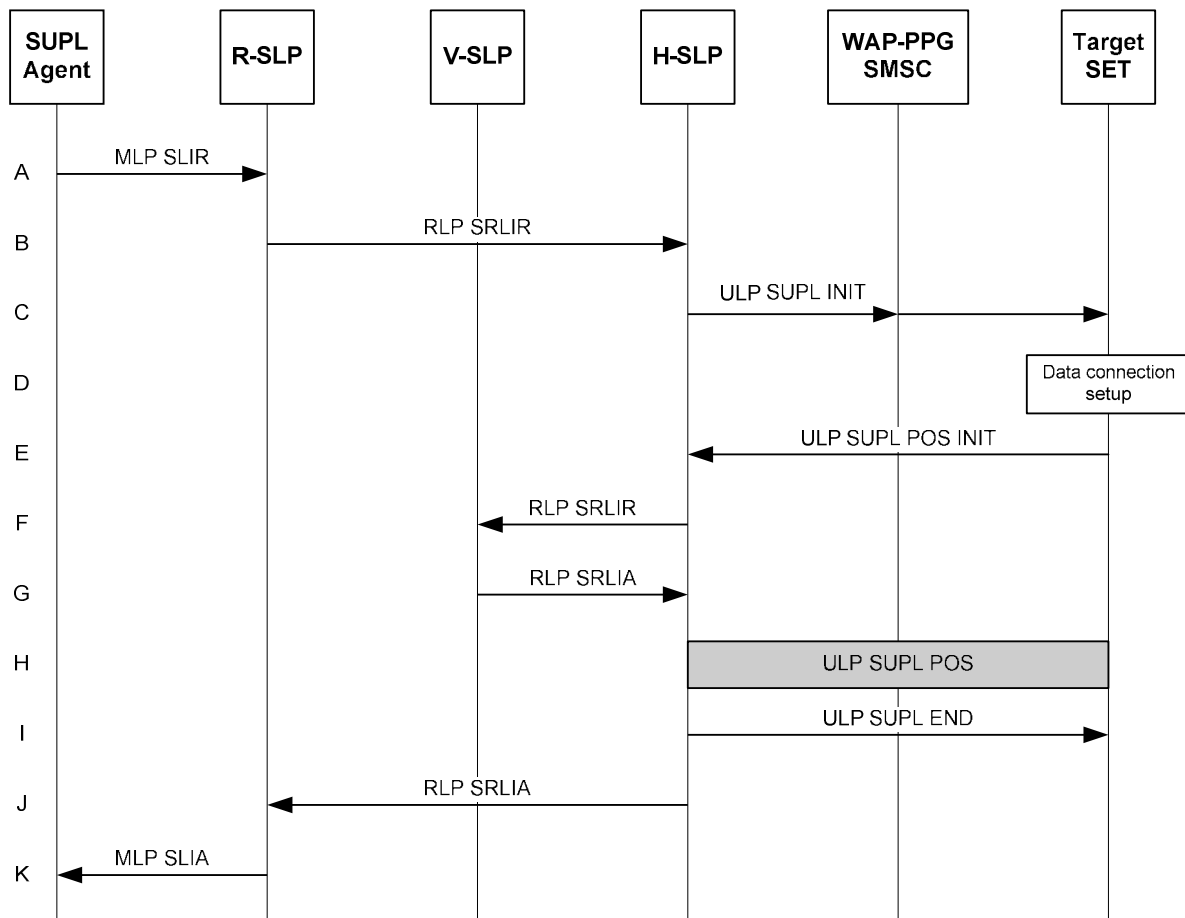

Figure 11: Network Initiated Roaming

- A. SUPL Agent issues an MLP SLIR message to the R-SLP.
 - B. The R-SLP forwards the location request to the H-SLP of the target subscriber, using an RLP SRLIR. The message contains the requested QoS.
 - C. The H-SLP initiates the location session with the SET using the ULP SUPL INIT message. The message contains the requested positioning method.
- Note: the WAP-PPG/SMSC network element is only involved if OMA Push or MT SMS is used for delivering the ULP SUPL INIT message to the SET.
- D. When the ULP SUPL INIT message is received by the SET it will establish a secure connection to the H-SLP.
 - E. The SET then sends a ULP SUPL POS INIT message to start a positioning session with the H-SLP. The message contains the SET capabilities. The ULP SUPL POS INIT message may also contain positioning protocol payload (LPP or TIA-801).
 - F. The H-SLP sends an RLP SRLIR message to the V-SLP to determine a coarse position for further exchange of ULP SUPL POS messages between SET and H-SLP.
 - G. The V-SLP returns an RLP SRLIA message. This message contains the position result (e.g., coarse position for A-GPS positioning).

- H. The H-SLP then determines the positioning method and exchanges several successive ULP SUPL POS messages. These messages contain the used positioning protocol messages (e.g., LPP or TIA-801) as needed to determine the position.
- I. When the position calculation is complete the H-SLP sends the ULP SUPL END message to the SET. The SET then releases the secure IP connection to the H-SLP.
- J. The H-SLP sends an RLP SRLIA message to the R-SLP. This message contains the position estimate.
- K. The R-SLP sends an MLP SLIA message to the SUPL Agent. This message contains the position estimate.

B.6 SET-Initiated GSS – Non Roaming

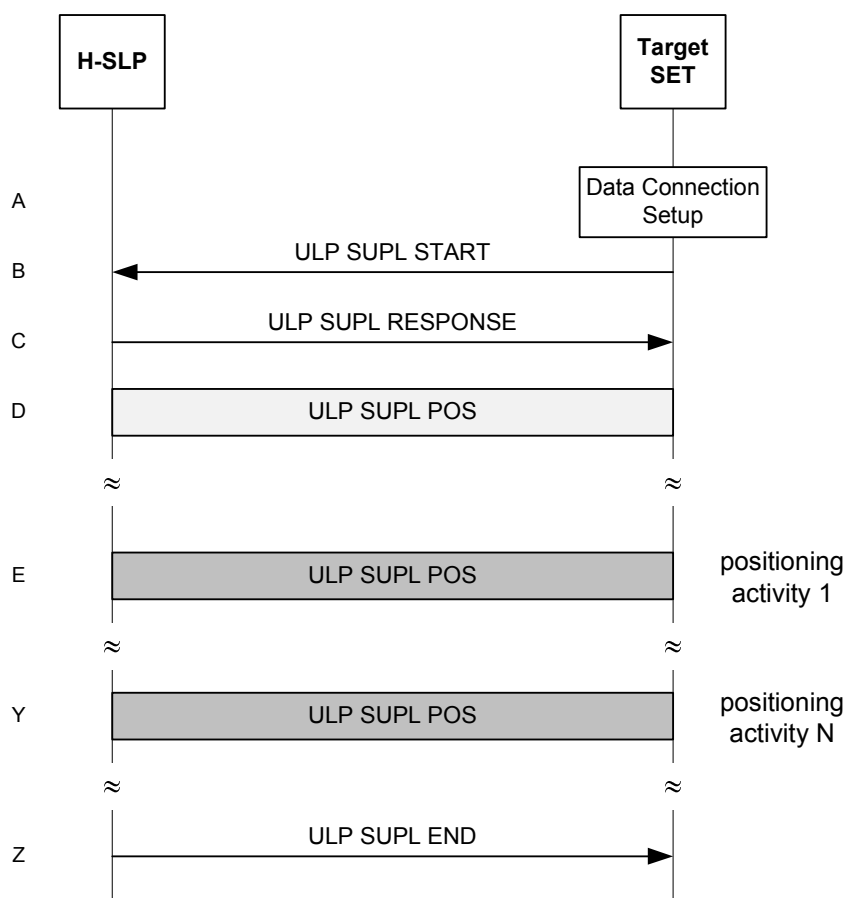

Figure 12: SET Initiated GSS

- A. The SUPL Agent on the SET requests the establishment of a GSS. The SET establishes a secure connection to the H-SLP.
- B. The SET sends a ULP SUPL START message to start a GSS with the H-SLP.
- C. The H-SLP responds with a ULP SUPL RESPONSE message to the SET.

The GSS is now established with a pre-defined lifetime. The SUPL Agent which initiated the GSS may at any time request a position activity such as assistance data provisioning, measurement and/or position request.

D. This step is optional and only performed by the SET and the H-SLP to exchange their positioning capabilities. SET and H-SLP exchange ULP SUPL POS messages carrying the positioning capabilities as part of the positioning protocol payload (LPP or TIA-801).

E. SET and H-SLP exchange ULP SUPL POS messages to execute the requested positioning activity.

Step E may be repeated as required and at any time during the lifetime of the GSS.

Z. When the end of the GSS is reached, the H-SLP sends a SUPL END message to the SET.

B.7 Network-Initiated GSS – Non Roaming

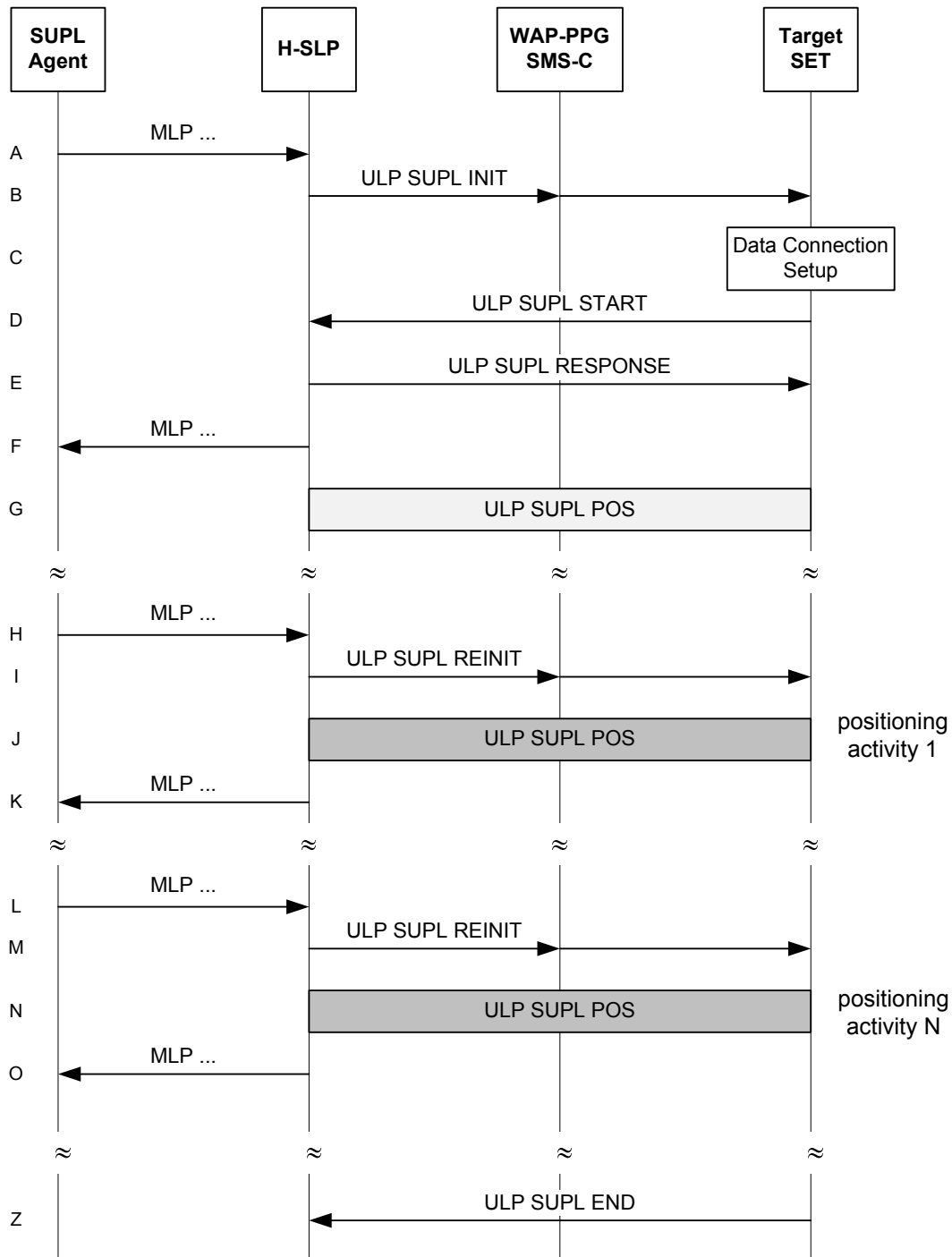

Figure 13: Network Initiated GSS

- A. The SUPL Agent may send an MLP request for location service to the H-SLP, with which it is associated. This step is only shown as an example to illustrate that a GSS may be established as a result of an MLP location request by the SUPL Agent. A GSS may also be established by the H-SLP based on some other event or condition and in the absence of any MLP location requests by the SUPL Agent.

- B. The H-SLP initiates the GSS with the SET by sending a ULP SUPL INIT message.
- C. When the ULP SUPL INIT message is received by the SET it establishes a secure connection to the H-SLP.
- D. The SET sends an ULP SUPL START message to the H-SLP.
- E. The H-SLP responds with a ULP SUPL RESPONSE message to the SET.
- F. This step is optional and may be performed by the H-SLP to acknowledge the MLP location request by the SUPL Agent in step A, if step A was performed.

The GSS is now established with a pre-defined lifetime. The H-SLP may at any time request a position activity such as assistance data provisioning, measurement and/or position request, etc. based on some condition or event.

- G. This step is optional and only performed by the SET and the H-SLP to exchange their positioning capabilities. SET and H-SLP exchange ULP SUPL POS messages carrying the positioning capabilities as part of the positioning protocol payload (LPP or TIA-801).
- H. This step is optional: a SUPL Agent (which may or may not be the same as the SUPL Agent of step A) sends an MLP request for location service to the H-SLP. This step is only shown as an example to illustrate that an MLP location service request may lead to a positioning activity.
- I. When the H-SLP decides to initiate a positioning activity (which may be the result of step H or some other condition or event) and no secure connection to the SET exists, the H-SLP sends an ULP SUPL REINIT message to the SET.
- J. SET and H-SLP exchange ULP SUPL POS messages to execute the requested positioning activity.
- K. This step is optional and may be performed by the H-SLP to provide a response to the SUPL Agent's request for location service and may include the results of the positioning activity in step H – if step H took place.

Steps H to K may be repeated as required and at any time during the lifetime of the GSS.

- Z. When the end of the GSS is reached, the SET sends an ULP SUPL END message to the H-SLP.

Appendix C. Llp Reference Point Flows (Informative)

The flows shown in this appendix show the Llp interface message exchange. The flows can be divided into two categories: Network Initiated and SET Initiated.

A Network Initiated flow occurs when the positioning is requested by a SUPL Agent in the network.

A SET Initiated flow occurs when the positioning is requested by the SET.

The flows presented in this appendix are intended to illustrate the basic concept and are not meant to provide a comprehensive description of the flows. Also, the flow scenarios presented here are not exhaustive but only represent a selected set of flows used to illustrate the basic flow concept. Refer to [OMA ILP] for a complete list of flows with detailed descriptions.

C.1 SET Initiated – Immediate Fix – Non-Roaming

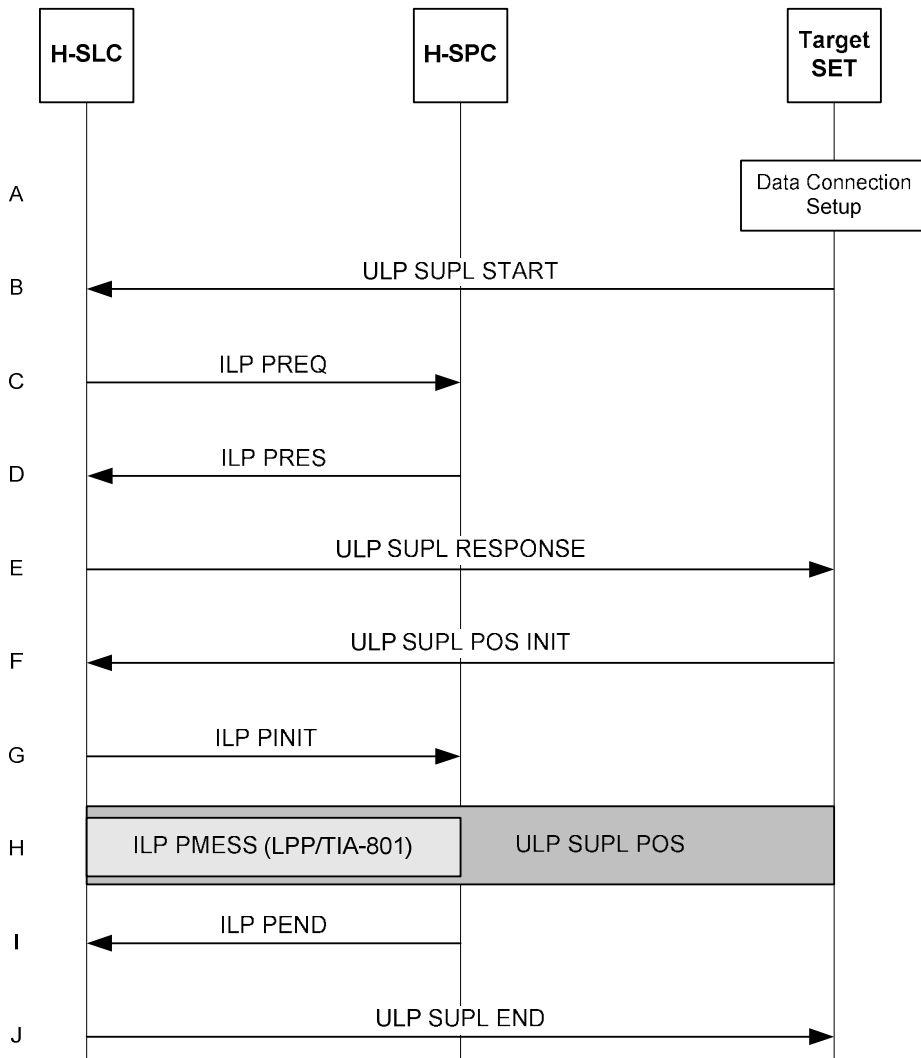

Figure 14: SET Initiated Non-Roaming Immediate Fix with Llp Interface

- A. The SUPL Agent on the SET receives a request for position from an application running on the SET. The SET establishes secure connection to the H-SLC.

- B. The SET sends a ULP SUPL START message to start a SUPL Session with the H-SLP.
- C. The H-SLC requests service from the H-SPC.
- D. The H-SPC responds to the service request from the H-SLC.
- E. The H-SLC sends a ULP SUPL RESPONSE message to the SET.
- F. The SET then sends a ULP SUPL POS INIT message to start a positioning session with the H-SLP. The ULP SUPL POS INIT message may contain positioning protocol payload (LPP or TIA-801).
- G. The H-SLC sends an ILP PINIT message to the H-SPC to start the SUPL POS session.
- H. The H-SPC determines the positioning method and engages in a SUPL POS session with the SET. Thereby the positioning payload (LPP or TIA-801) is transferred between the H-SPC and the H-SLC using ILP PMESS messages, and between the H-SLC and the SET using SUPL POS messages.
- I. When the position calculation is complete the H-SPC sends an ILP PEND message to the H-SLC.
- J. The H-SLC sends a ULP SUPL END message to the SET. The SET then releases the secure connection to the H-SLC.

C.2 Network Initiated – Immediate Fix – Non-Roaming

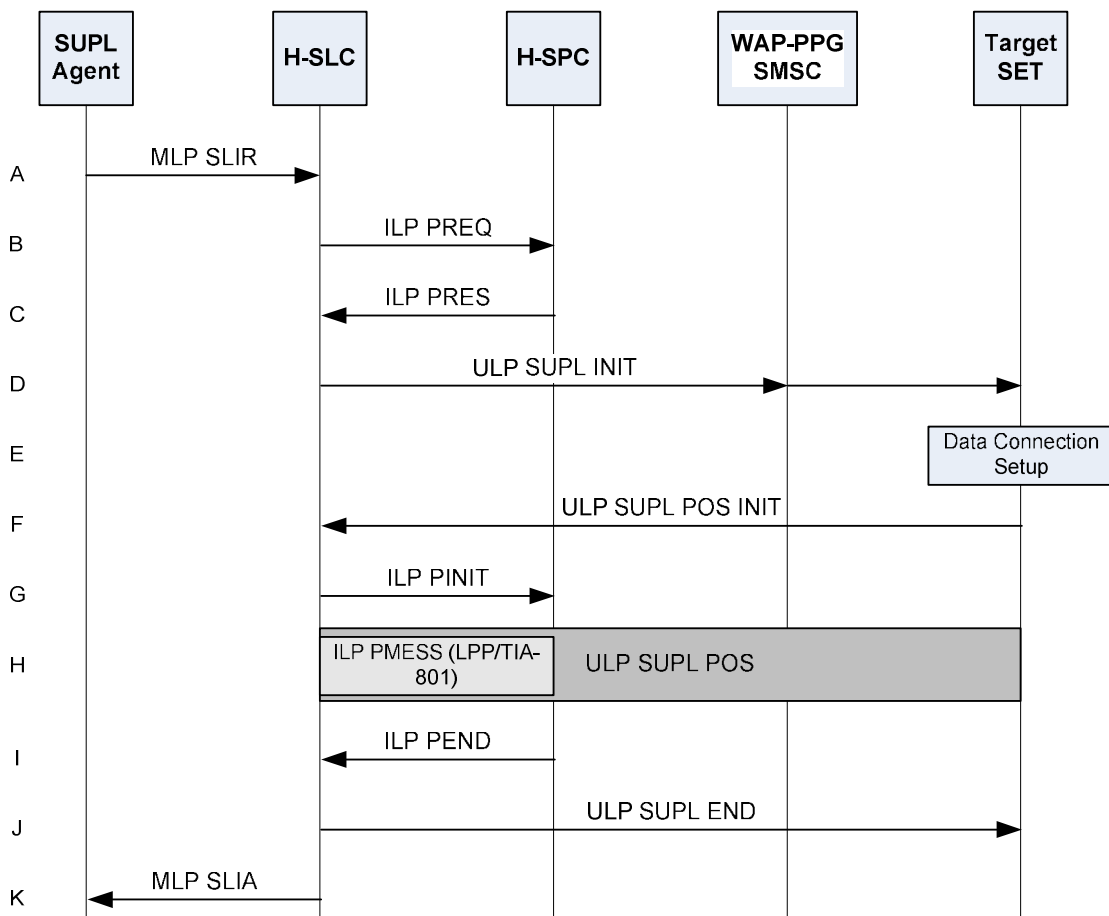

Figure 15: Network Initiated Non-Roaming Immediate Fix with Llp Interface

- A. SUPL Agent issues an MLP SLIR message to the H-SLC.

- B. The H-SLC requests service from the H-SPC.
- C. The H-SPC responds to the service request from the H-SLC.
- D. The H-SLC initiates the SUPL Session with the SET by sending a ULP SUPL INIT message. The message contains the requested positioning method and QoS.

Note: the WAP-PPG/SMS-C network element is only involved if OMA Push or MT SMS is used for delivering the ULP SUPL INIT message to the SET.

- E. When the ULP SUPL INIT is received by the SET it will establish a secure connection to the H-SLC.
- F. The SET then sends a ULP SUPL POS INIT message to start a positioning session with the H-SLP. The ULP SUPL POS INIT message may contain positioning protocol payload (LPP or TIA-801).
- G. The H-SLC sends an ILP PINIT message to the H-SPC to start the SUPL POS session.
- H. The H-SPC determines the positioning method and engages in a SUPL POS session with the SET. Thereby the positioning payload (LPP or TIA-801) is transferred between the H-SPC and the H-SLC using ILP PMESS messages, and between the H-SLC and the SET using SUPL POS messages.
- I. When the position calculation is complete the H-SPC sends an ILP PEND message to the H-SLC including the position estimate.
- J. The H-SLC sends a ULP SUPL END message to the SET. The SET then releases the secure connection to the H-SLC.
- K. The H-SLC sends the position estimate back to the SUPL Agent by means of an MLP SLIA message.