



System Architecture Model

Version 1.0

WV Tracking Number: WV-001

Notice

Copyright © 2001-2002 **Ericsson, Motorola and Nokia**. All Rights Reserved.

Implementation of all or part of any Specification may require licenses under third party intellectual property rights, including without limitation, patent rights (such a third party may or may not be a Supporter). The Sponsors of the Specification are not responsible and shall not be held responsible in any manner for identifying or failing to identify any or all such third party intellectual property rights.

THIS DOCUMENT AND THE INFORMATION CONTAINED HEREIN ARE PROVIDED ON AN "AS IS" BASIS WITHOUT WARRANTY OF ANY KIND AND ERICSSON, MOTOROLA and NOKIA DISCLAIM ALL WARRANTIES, EXPRESS OR IMPLIED, INCLUDING BUT NOT LIMITED TO ANY WARRANTY THAT THE USE OF THE INFORMATION HEREIN WILL NOT INFRINGE ANY RIGHTS OR ANY IMPLIED WARRANTIES OF MERCHANTABILITY OR FITNESS FOR A PARTICULAR PURPOSE. IN NO EVENT SHALL ERICSSON, MOTOROLA or NOKIA BE LIABLE TO ANY PARTY FOR ANY LOSS OF PROFITS, LOSS OF BUSINESS, LOSS OF USE OF DATA, INTERRUPTION OF BUSINESS, OR FOR DIRECT, INDIRECT, SPECIAL OR EXEMPLARY, INCIDENTAL, PUNITIVE OR CONSEQUENTIAL DAMAGES OF ANY KIND IN CONNECTION WITH THIS DOCUMENT OR THE INFORMATION CONTAINED HEREIN, EVEN IF ADVISED OF THE POSSIBILITY OF SUCH LOSS OR DAMAGE. The above notice and this paragraph must be included on all copies of this document that are made.

Table of Contents

1	Introduction	4
2	References.....	4
3	Definitions and Abbreviations.....	4
	3.1 Abbreviations	4
4	System Architecture.....	5
5	Functional Description of Architectural Elements.....	6
	5.1 WV Server	6
	5.1.1 Presence Service Element.....	6
	5.1.2 Instant Messaging Service Element	7
	5.1.3 Group Service Element.....	7
	5.1.4 Content Service Element.....	7
	5.1.5 Service Access Point.....	7
	5.2 WV Embedded Client	9
	5.3 CLI Client.....	9
6	Interfaces and Protocols	10
	6.1 Client Server Protocol (CSP)	10
	6.2 Command Line Protocol (CLP).....	10
	6.3 Server Server Protocol (SSP).....	10
	6.4 Server Mobile Core Network Protocol (SMCNP).....	10

1 Introduction

Founded by Ericsson, Motorola and Nokia, Wireless Village, the Mobile Instant Messaging and Presence Services (IMPS) Initiative, was formed in to define and promote a set of universal specifications for mobile instant messaging and presence services. The specifications will be used for exchanging messages and presence information between mobile devices, mobile services and Internet-based instant messaging services, all fully interoperable and leveraging existing web technologies.

2 References

[RFC2778] A Model for Presence and Instant Messaging, [RFC 2778](#), February 2000

[RFC2779] Instant Messaging / Presence Protocol Requirements, [RFC 2779](#), Feb. 2000

[IMPP-CPIM] A Common Profile for Instant Messaging (CPIM), Internet Draft <[draft-ietf-impp-cpim-01](#)>, November 2000

[TS 22.121] Digital cellular telecommunications system (Phase 2+) (GSM); Universal Mobile Telecommunications System (UMTS); Service aspects; The Virtual Home Environment (3GPP TS 22.121 version 4.1.0 Release 4)

[TS 23.127] Universal Mobile Telecommunications System (UMTS); Virtual Home Environment/Open Service Architecture (3GPP TS 23.127 version 4.2.0 Release 4)

3 Definitions and Abbreviations

3.1 Abbreviations

CLP Command Line Protocol

CLI Command Line Interface

WV Wireless Village

CSP Client Server Protocol

SSP Server Server Protocol

MCN Mobile Core Network

IM&P Instant Messaging and Presence

IMPS Instant Messaging and Presence Services

SMCNP Server to Mobile Core Network Protocol

4 System Architecture

The System Architecture describes the IMPS system and its relation to the mobile networking and the Internet. This is a client-server-based system, where the server is the IMPS server and clients can be either mobile terminals, or other services/applications, or fixed PC-clients. For interoperability, the IMPS servers and Gateways are connected with a Server-to-Server Protocol (SSP). The architecture gives implementers more choices in WV Servers or Gateways, but with WV brand and technology.

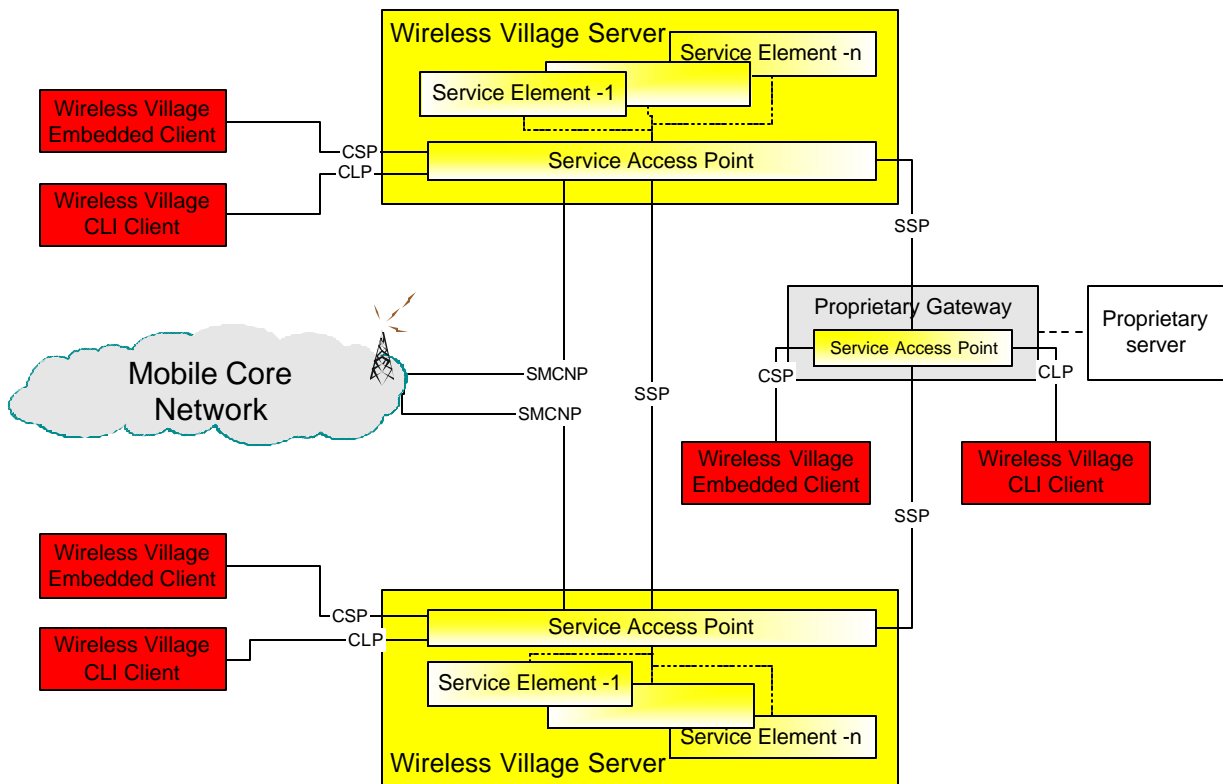

Figure 1: The Wireless Village System Architecture Model

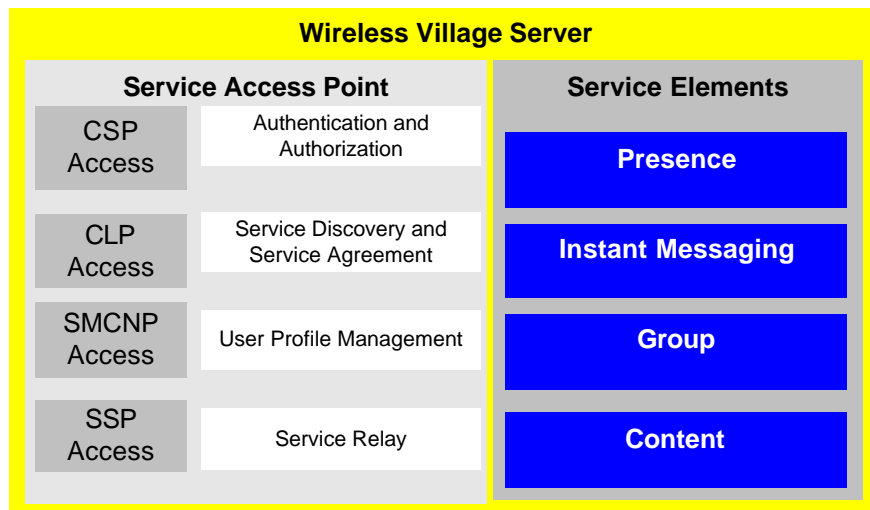

Figure 2: Functional Elements of Wireless Village Server

5 Functional Description of Architectural Elements

5.1 WV Server

The Wireless Village Server is the central point in a Wireless Village system. It is composed of four Application Service Elements that are accessible via the Service Access Point. The Application Service Elements are:

- Presence Service Element
- Instant Messaging Service Element
- Group Service Element
- Content Service Element

5.1.1 Presence Service Element

The Presence Service Element provides functionality for presence information management. This includes update, retrieve, set and store presence and location information. Presence information can be manipulated implicitly by the system, or explicitly by the user.

A user can subscribe to receive the presence information of other users, as specified in a contact list. Contact List Management is also a part of the presence service.

Presence information can be fetched from different internal and external sources. Through the Service Access Point (described below) the Presence Service Element can connect to the Mobile Core Network to access network presence and service information. Network presence defines the properties of the mobile devices, as well as the underlying

network functionality. The Network service features define the properties related to the wireless devices on the wireless network, and determine the ability to communicate with a particular wireless device.

5.1.2 Instant Messaging Service Element

The Instant Messaging Service Element provides functionality for sending and receiving instant messages. An instant message may be sent to, or received from, a specific WV-user, or users of other instant messaging systems. It is also possible to send instant messages to a group of WV-users. WV supports several messages types, such as plain text, video, picture and sound.

5.1.3 Group Service Element

The Group Service Element provides functionality for use and management of groups. The groups can be private or public. A common usage of the Group Service is a chat room. It is also possible to bind content to the Groups.

5.1.4 Content Service Element

The Content Service Element provides functionality for sharing content such as images and documents between Wireless Village users. The shared content feature allows the IMPS users to share content, while sending messages or chatting in a group.

5.1.5 Service Access Point

The Service Access Point (SAP) serves as the interface between the WV server and its environment. It has interfaces to the WV clients, other WV servers, the Mobile Core Network and Proprietary Gateways to non-WV servers.

The functionality of the Service Access Point is:

- Authentication and Authorization
- Service Discovery and Service Agreement
- User Profile Management
- Service Relay

Some potentially useful functions, such as a service administration and monitoring interface, a provisioning interface, and a billing interface, etc., are subject to the implementation in the real world. Those functions are outside of the scope of the Wireless Village and will not be addressed within this document.

5.1.5.1 Authentication and Authorization

Authentication is used to verify the identity of an entity (user, network, or application). Authorization is the activity of determining what an authenticated entity (user, network, or application) is allowed to do.

There are several types of mechanisms for authentication and authorization:

- Application-Network Authentication / Authorization.
- User-Application Authentication / Authorization.
- Application-Application Authentication / Authorization
- User-Network Authentication (only for Authentication)

5.1.5.2 Service Discovery and Service Agreement

Service Discovery enables the application to identify the total collection of service capability features that it can use. The service discovery process includes service capability registration and service capability notification. This is done both between Client – Server and Server –Server.

A **Service Agreement** (also known as a Service Level Agreement) must be established before the server can interact with the Network Service Capability or other servers' service capabilities, and provides the client with the services.

Upon successful authentication, the server may obtain information about the network capability and service capability features. The client may obtain the service capability features provided by the server. The services include the network services and IMPS services (presence service, IM service, group service and shared content service).

5.1.5.3 User Profile Management

One or more User Profile(s) describe(s) how the user wishes to manage and interact with their communication services. The User Profile information consists of various user interfaces and service related information including the list of services to which the end-user is subscribed, preferences associated with those services, service status (active / inactive), privacy status with regards to network service capabilities (e.g. user location, user interaction), terminal capabilities and terminal interface preferences etc.

User Profile Management allows the application to retrieve and update the user profile.

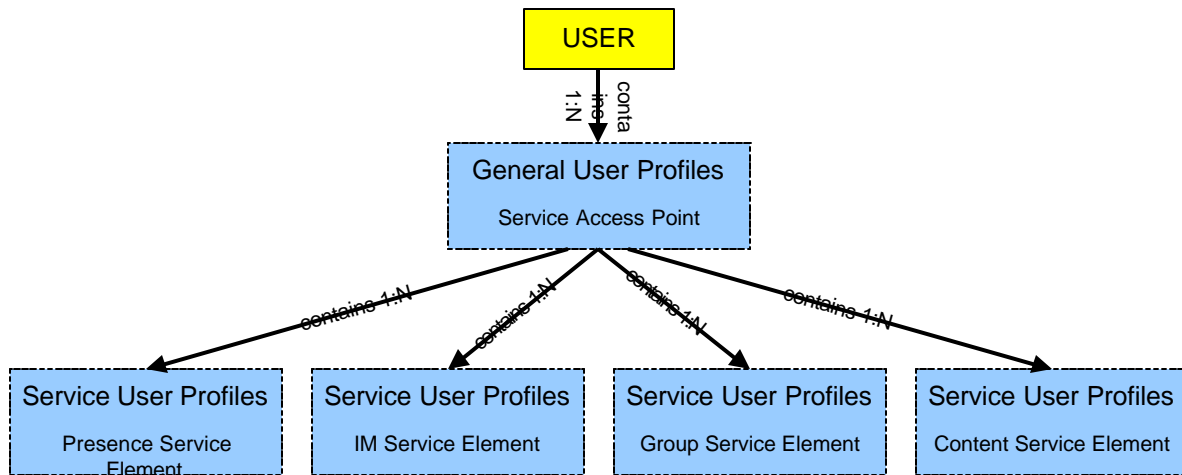

Figure 3: User Profiles

5.1.5.4 Service Relay

The Service Access Point must provide the Service Relay function to route all service requests and responses among the servers through the Server-to-Server Protocol (SSP). The protocol conversion from CSP to SSP and message codec may be needed when performing Service Relay.

5.2 WV Embedded Client

The Wireless Village Embedded Client is an embedded client within a mobile terminal. The clients from different vendors will have a different look, and they will not have the exact same functionality. It is possible to take the functions from the Wireless Village system and combined them with the functions from the mobile terminal, e.g. the phonebook. The benefit with the Wireless Village embedded client is that despite the difference in the clients, they will be fully interoperable with each other through the Client Server Protocol.

5.3 CLI Client

The Command Line Interface Client uses text messages to communicate with the Wireless Village server. The functionality provided might be a subset of the functionality provided by an Embedded Client. An Example of a CLI Client is a mobile terminal that uses SMS to communicate with the Wireless Village server.

6 Interfaces and Protocols

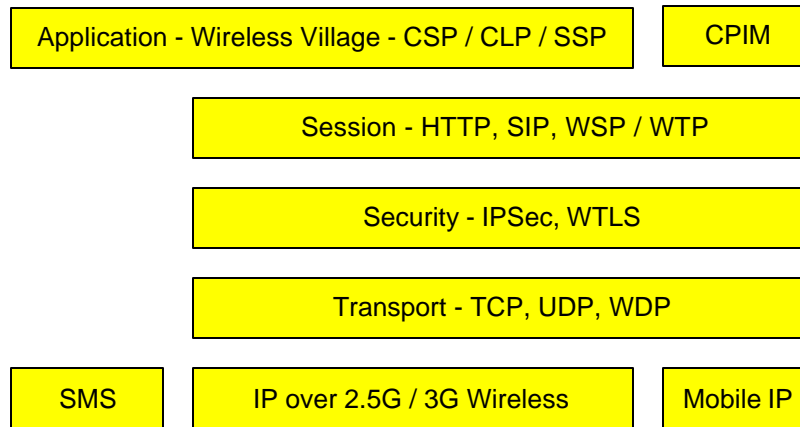

Figure 4: Interfaces and Protocols

6.1 Client Server Protocol (CSP)

The Client-Server Protocol provides access for Embedded Clients within mobile terminals and desktop clients to access the Wireless Village Server. The protocol can use different bearers depending on the capability of the client.

6.2 Command Line Protocol (CLP)

The Command Line Protocol makes it possible to provide access for legacy terminals via a command line client to the Wireless Village server.

6.3 Server Server Protocol (SSP)

The Server-Server Protocol connects Wireless Village servers. This can be used within one service provider domain or between different service providers. In this way the system will be interoperable so that a user that subscribes to Wireless Village services at Service Provider A can communicate with a user that is a customer of Service Provider B. The SSP is also used when connecting a Wireless Village server to Proprietary IMPS service via a Proprietary Gateway.

6.4 Server Mobile Core Network Protocol (SMCNP)

The Server Mobile Core Network Protocol gives access to the Mobile Core Network so that the Wireless Village server can get presence information and service capability information from the network. The SMCNP can also be used for authentication and authorization of users, clients and servers.